

## Chapter 97

### PUSH SWITCH, ROTAX, TYPE D10601

#### LIST OF CONTENTS

	<i>Para.</i>		<i>Para.</i>
<i>Introduction</i> .. .. .	1	<b>Installation</b> .. .. .	5
<b>Description</b> .. .. .	2	<b>Servicing</b> .. .. .	6
<i>Electrical connections</i> .. .. .	4	<i>Testing</i> .. .. .	8

#### LIST OF ILLUSTRATIONS

	<i>Fig.</i>
<i>Push switch, Type D10601</i> .. .. .	1
<i>Circuit diagram</i> .. .. .	2

#### LIST OF APPENDICES

	<i>App.</i>
<i>Standard serviceability test for push switch, Rotax, Type D10601</i> .. .. .	A

#### LEADING PARTICULARS

<b>Push switch, Type D10601</b> .. .. .	<b>Ref. No. 5CW/6408</b>
<i>Voltage</i> .. .. .	29 volts (max.)
<i>Current rating</i> .. .. .	10 amp (resistive)
<i>Time rating</i> .. .. .	Continuous
<i>Temperature range</i> .. .. .	-65 deg C to +70 deg C
<i>Operational ceiling</i> .. .. .	60,000 ft.
<i>Overall dimensions—</i>	
<i>Length</i> .. .. .	1.954 in.
<i>Width</i> .. .. .	0.750 in.
<i>Height</i> .. .. .	2.155 in.
<i>Weight</i> .. .. .	1 $\frac{3}{4}$ oz.

#### **Introduction**

1. The D10601 is a manually operated push-button switch for use in 28 volt d.c. circuits, and continuously rated at 10 amp. It is a changeover, centre on switch with contacts 2 and 3 made, and contacts 1 and 2 normally open.

#### **DESCRIPTION**

2. The switch mechanism is contained within a frame mounted on the moulded base, and consists of a spring-loaded plunger, operating arm, operating rollers and contact assembly. The switch is enclosed in a moulded body through which the operating button projects.

3. When the operating plunger is depressed, the operating arm swings over, carrying in the slotted guides, the operating rollers which move across the pivoted moving contact carrier to open contacts 2 and 3, and close contacts 1 and 2. Contact pressure is maintained by the plunger spring via the roller carrier plate.

#### **Note . . .**

*The load required to operate the push button should be between 5 and 9 lb.*

#### **Electrical connections**

4. Three 4 B.A. combined screw and washer terminations suitable for 19 amp.

### RESTRICTED

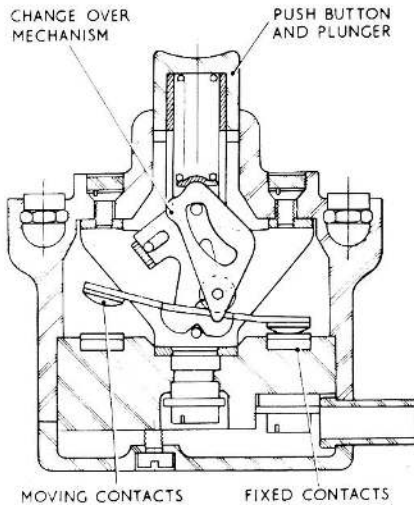

**Fig. 1. Push switch, Type D10601**

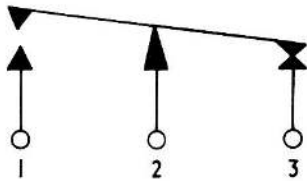

**Fig. 2. Circuit diagram**

cables are provided in the moulded base. Four cable entries with rubber grommets and a detachable cover are also provided to protect the terminations and connecting leads.

## INSTALLATION

5. Two 4 B.A. fixing holes 0.187 in. deep are provided at 1.580 in. centres in switch moulding tapped bushes. When mounted in a bank a minimum clearance of 0.032 in. should be allowed between each switch.

## SERVICING

6. It is not recommended that these switches be dismantled as they have been sealed after manufacture and test. Periodically, however, they should be inspected to ensure that there is no apparent physical damage. The body moulding and base cover should be carefully examined for signs of cracking or distortion and the unit should be firmly secured to its mountings.

7. Terminals should be examined where it is possible to do so without removing the unit from its installation, and these should be clean and free from corrosion. If the unit satisfies this visual check and functions correctly in its associated circuit, it can be considered serviceable for continued use. Where a switch is found to be in any way defective, it should be removed and a serviceable one fitted.

## Testing

8. If the serviceability of the switch is suspect, it may be tested as laid down in Appendix A.

**RESTRICTED**

## Appendix A

# STANDARD SERVICEABILITY TEST FOR PUSH SWITCH, ROTAX, TYPE D10601

### Introduction

1. The following tests may be applied to the switch before it is put into service, or at any time when its serviceability is suspect.

### Test equipment

2. The following test equipment is required:

- (1) Suitable 0—15A d.c. ammeter.
- (2) Multimeter, Type 12889 (Ref. No. 5QP/17447) or equivalent.
- (3) Insulation resistance tester, Type C (Ref. No. 5G/152).

### Testing

#### *Millivolt drop test*

3. With the rated current of 10 amp. at 28 volts flowing through the appropriate contacts when in the closed position, the millivolt drop across the terminals should not exceed 70 mV.

#### *Insulation resistance test*

4. The insulation resistance, when measured between all terminals not connected together, with the switch in the normal and operated positions, using a 250-volt insulation resistance tester, should not be less than 0.5 megohm (for R.N.), or 5 megohms (for R.A.F.).

**RESTRICTED**

This file was downloaded  
from the RTFM Library.  
Link: [www.scottbouch.com/rtfm](http://www.scottbouch.com/rtfm)

Please see site for usage terms,  
and more aircraft documents.

