

# Chapter I

## PROPELLER CONTROL CHANNEL UNIT

### LIST OF CONTENTS

|                               | Para. |                                   | Para. |
|-------------------------------|-------|-----------------------------------|-------|
| Introduction... ..            | 1     | Servicing... ..                   | 23    |
| <b>Description</b>            |       | Mounting rack assembly ... ..     | 25    |
| Control channel unit... ..    | 2     | Functional continuity test ... .. | 29    |
| Mounting rack assembly ... .. | 3     | Capacitors ... ..                 | 30    |
| Relay, Type 4190HD ... ..     | 6     | Resistors ... ..                  | 31    |
| Common control channel ... .. | 7     | Common control channel ... ..     | 32    |
| Engine control channel ... .. | 9     | Functional test ... ..            | 35    |
| Operation ... ..              | 11    | Relays ... ..                     | 36    |
| Mounting rack assembly ... .. | 13    | Engine control channel ... ..     | 38    |
| Common control channel ... .. | 14    | Functional test ... ..            | 41    |
| Engine control channel ... .. | 15    | Relays ... ..                     | 42    |
| Installation ... ..           | 21    | Rectifiers ... ..                 | 43    |

### LIST OF ILLUSTRATIONS

|   | Fig. |   | Fig. |
|---|------|---|------|
| General view of control channel unit ... ..   | 1    | Engine control channel (cover removed) ... ..             | 5    |
| Mounting rack assembly (top view) ... ..      | 2    | Theoretical circuit diagram ... ..                        | 6    |
| Mounting rack assembly (bottom view) ... ..   | 3    | Wiring diagram, mounting rack assembly ... ..             | 7    |
| Common control channel (cover removed) ... .. | 4    | Wiring diagram, engine and common control channels ... .. | 8    |

### LIST OF APPENDICES

|                  |  | App. |
|------------------|--|------|
| Test rigs ... .. |  | 1    |

### LEADING PARTICULARS

|   |                      |
|---|----------------------|
| Control channel unit, comprising—                 |                      |
| Mounting rack assembly ... ..                     | Q1108                |
| Common control channel assembly ... ..            | Q1103                |
| Engine control channel assembly ... ..            | Q1104                |
| Overall dimensions—                               |                      |
| Length ... ..                                     | 16 $\frac{1}{8}$ in. |
| Width ... ..                                      | 5 $\frac{3}{4}$ in.  |
| Height (including anti-vibration mounting) ... .. | 7 in. (max.)         |
| Weight ... ..                                     | 10 lb. 14 oz.        |

## Introduction

1. The purpose of the control channel unit is to group together various relays, resistors, rectifiers and capacitors appertaining to the electrical side of propeller control. This arrangement facilitates inspection and testing of units and their removal and renewal should this prove necessary.

## DESCRIPTION

### Control channel unit

2. The control channel unit (*fig. 1*) comprises the following main components:—

one mounting rack assembly, four engine control channel assemblies, and one common control channel assembly. In both the engine and common control channels are a number of sealed type, double-contact midget relays, Type 4190HD. The rack, which is attached to the aircraft by means of flexible spring mountings, forms a base for the five control channel assemblies.

### Mounting rack assembly

3. The mounting rack assembly (*fig. 2 and 3*) consists mainly of a box-shaped case built up from alloy sheeting. Two extensions support

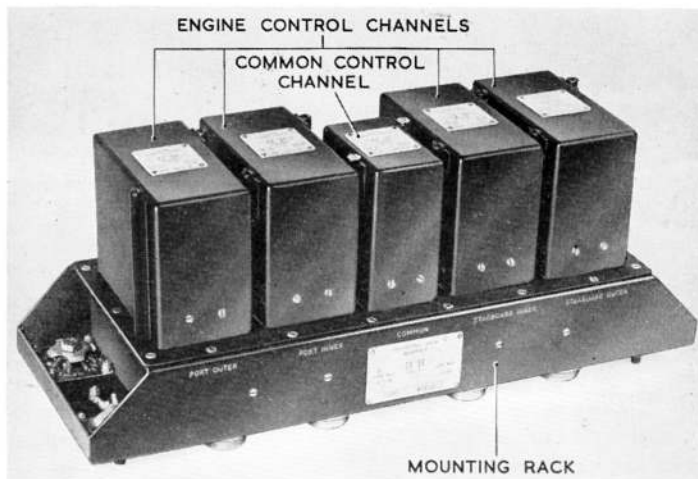

Fig. 1. General view of control channel unit

the flexible mountings. The flat top plate contains five Pye sockets mounted in line, the centre one being a twelve-way unit, whilst the other four are twenty-way units (*fig. 2*). The central socket accommodates the Pye plug of the common control channel and the remaining four sockets accommodate the plugs of the engine control channels. Sockets and plugs are so designed that they will mate in only one position.

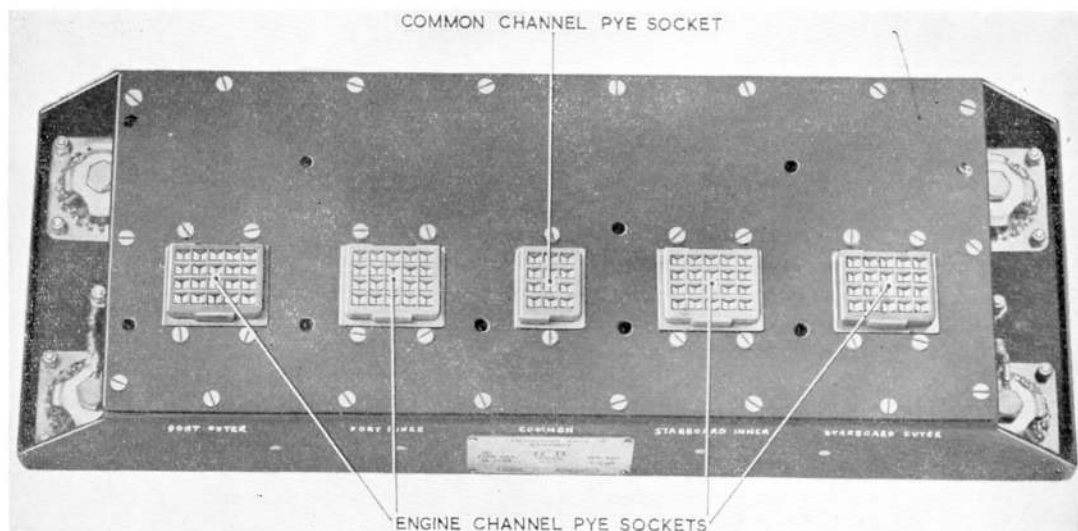

Fig. 2. Mounting rack assembly (top view)

RESTRICTED

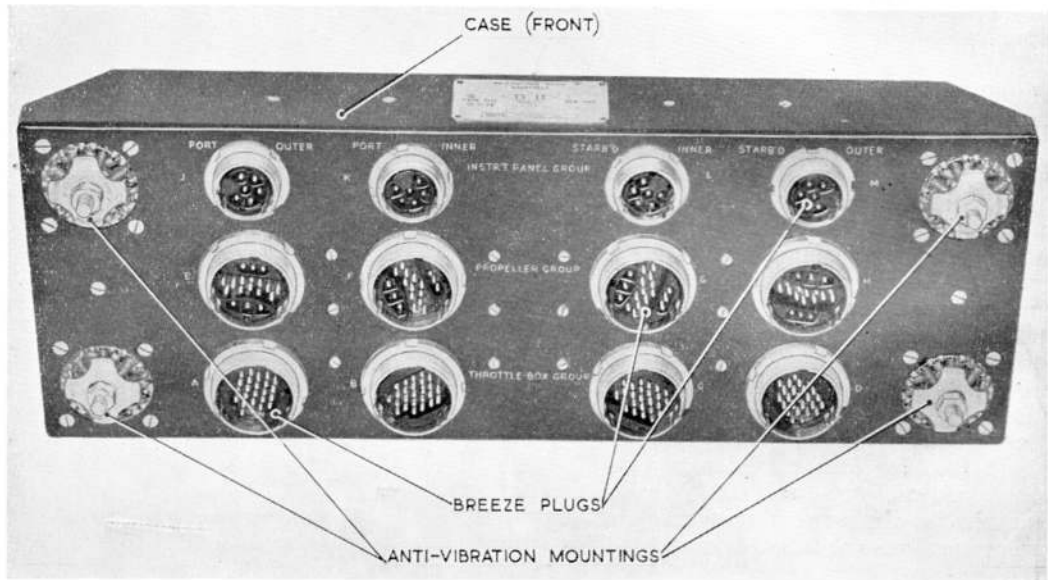

Fig. 3. Mounting rack assembly (bottom view)

4. On the underside of the rack are mounted twelve Breeze plugs arranged in three rows of four plugs (*fig. 3*). The bottom row of four 25-pole plugs make connections to the throttle-box, the middle row of four 18-pole plugs connect to propeller units and the top row of four 6-pole plugs serve units on the instrument panel. The extension plates for attachment of the four anti-vibration spring mountings are also at the bottom of the rack, as are the two bonding leads from the centre mounting bolts to the chassis.

5. Attached to the inside of the rack are four capacitors mounted in Terry clips and four resistors mounted on turret lugs. The inside of the rack also houses and protects the wire connections between Pye sockets, Breeze plugs and other units. These can be seen on the wiring diagram (*fig. 7*).

#### Relay, Type 4190HD

6. Eighteen of these relays are used in the control channel unit, two in the common control channel and four in each of the four engine control channels. The relay is a medium-duty, sealed, double-contact change-over relay, of which a full description will be found in Sect. 3 of this publication.

#### Common control channel

7. This unit (*fig. 4*), which is common to all propellers, is plugged into the centre Pye socket on the rack. It is further secured by two Dzus fasteners. The control channel comprises a rectangular aluminium alloy frame, the base accommodates a twelve-way Pye plug and clamp assembly, whilst two relay base sockets are screwed to the top side of the frame. The Pye plug and clamp are mounted on a sub-frame, screwed to the bottom chassis flange for easy removal.

8. Each of the two relays (LI and LO) is secured to its base-socket by one 4 B.A. and one 6 B.A. stud. These studs are held down by a mounting strip, followed by the respective spring washers and thin-nuts. This arrangement avoids any possibility of incorrect assembly and assures vibration-proof contact of pins and sockets. The wiring connections are housed inside the chassis and can be followed on the diagram (*fig. 8B*). Overall protection is effected by a dust cover which slides over the relays and chassis from the top, and is fastened to the rack by two long Dzus fasteners situated diagonally, one on each side of the cover. All internal wiring and terminals are protected by a P.V.C. coating.

#### Engine control channel

9. All four engine control channels (fig. 5) are identical. They are similar generally to the common control channel (para. 7 and 8), with the addition of two further relays, making four in all (TL, ACP, RG and UB), and a triple rectifier assembly.

10. The rectifier assembly consists of a square S.R.B.P. mounting block carrying a centrally-disposed common terminal pillar and a triangular connecting plate, which serves as the upper mounting for the three equally-spaced germanium junction rectifiers. The lower ends of the rectifiers are screwed into separate brass inserts carrying a terminal screw and washer at the bottom end. The brass inserts are pressed into the mounting block which in turn is attached to the top chassis face by four csk/hd. screws. The chassis is cut out sufficiently to allow clearance for the bottom terminals and all wire connections are situated inside it. The

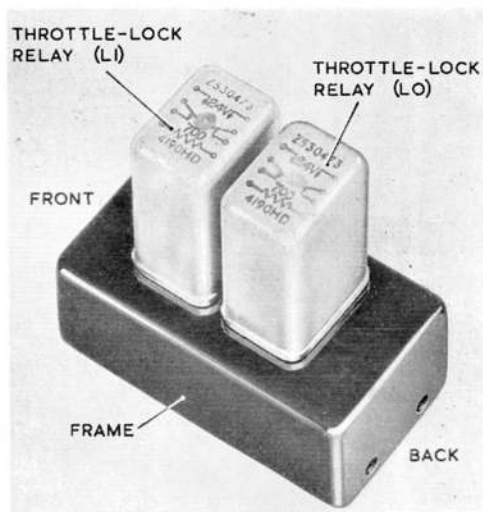

Fig. 4. Common control channel (cover removed)

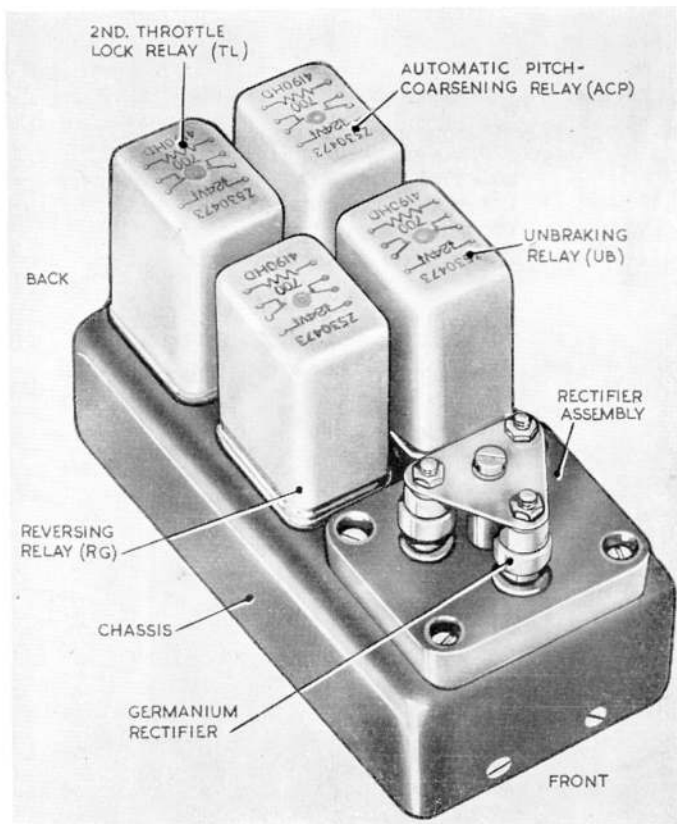

Fig. 5. Engine control channel (cover removed)

wiring diagram is given in fig. 8A. All internal wiring and terminals are protected by a P.V.C. coating.

#### OPERATION

11. The following paragraphs should be read in conjunction with A.P.1538Q, Vol. 1, Sect. 1, Chap. 2, also A.P.4512A, Vol. 1, Book 2, Sect. 5, Chap. 1, Groups J and K, where the operation of the whole propeller control system is described. A theoretical circuit diagram of the control channel unit is given in fig. 6.

12. In considering the operation of the control channel unit it must be realized that the only moving parts are the relay armatures and hinge contacts and that, apart from these, the unit serves largely as a channel or means of distribution for the various electrical circuits involved.

#### Mounting rack assembly

13. The mounting rack assembly carries no moving parts and serves mainly as a means of distribution between the Breeze plug con-

RESTRICTED

nections A-M on one side and the Pye-sockets N, S, Q, R and P on the other side. Of the four capacitors installed in this assembly, No. 1 and 4 serve the common control channel relays LI and LO so reducing arcing at their contact points, whilst No. 2 and 3 are connected to one pair of TL relays each (situated on the engine control channels), the two outer engines being paired in this instance as are the two inner ones. The four resistors are connected across the feathering button hold-coils via Breeze plugs J, K, L and M, so assisting to relieve inductance when the hold-in circuit is broken.

#### Common control channel

**14.** The common control channel is concerned with the arming circuits, and each relay assists in completing one of the two circuits. Each relay uses both switches on the operate side (normally open) and one on the de-operate side (to earth). On being energized by the UC relay the two operate switch-contacts on each of the throttle-lock relays LI and LO close. The operate switches of each relay, being in series via the pilot's selector, complete the two arming circuits, subject to the throttle switch being at the "idle + 10 per cent" position. The relay connections are made via Pye plug and socket Q and the 25-way Breeze plugs on the rack assembly. When viewing the common control channel in its normally mounted position with nameplate upright, the LO relay, forming a part of the outer engines arming circuit, lies at the top, whilst the LI relay serving the inner engines arming circuit is placed at the bottom.

#### Engine control channel

**15.** The "2nd throttle lock" relay TL actuated by the blade-switches utilizes the operate position (normally open) of the two switches only. One of these is connected in series with the operate switch of its paired channel TL relay (Port outer with Starboard outer, Port inner with Starboard inner), the other is in parallel with the counterpart switch of its paired relay. This relay is operative in energizing the 2nd throttle lock solenoid.

**16.** The automatic pitch-coarsening relay ACP is energized by the low-torque switch, under certain conditions, and uses both switches on the operate side and one on the de-operate side. The two operate switch connections form part of the automatic pitch-

coarsening circuit, whilst the de-operate switch connection is part of the feathering circuit.

**17.** The reversing relay RG utilizes all six switch connections and is actuated by the throttle switch. One of the normally made contacts forms a part of the feathering and A.C.P. circuits and the other assists in the unbraking sequence. Of the two switches in the operate position, one connects to the coarse-pitch solenoid via the blade-switches and the other forms a second connection to this solenoid by means of the throttle switch.

**18.** The unbraking relay UB is energized from the blade switch and utilizes one de-operate switch connection and two operate switch connections. The de-operate connection provides a current path in the feathering and A.C.P. circuits, whereas the two operate switch connections are in series and form a part of the coarse-pitch circuit during unbraking. One of the latter also connects to the FP-Y blade switch and operates the coarse-pitch solenoid if the fine-pitch stop fails to re-engage.

**19.** The three germanium junction rectifiers, which have a common negative terminal plate, are connected across the reversing solenoid, the maximum pressure solenoid and the coarse-pitch solenoid respectively. Their function is to relieve induction load when these circuits are broken; under normal operating conditions they are non-conductors.

**20.** Electrical connections from the engine control channels are made via the Pye plugs and sockets N, S, R and P and thence by way of the Breeze plug connectors to the aircraft cabling. Detail wiring of the channels and the mounting rack can be followed in fig. 7 and 8.

#### INSTALLATION

**21.** The control channel unit is intended to be mounted horizontally and is attached to the aircraft racking by four  $\frac{1}{4}$  in. B.S.F. bolts and nuts. A position avoiding excessive vibration or condensation should preferably be selected. The Breeze plugs should be screwed to their female counterparts, so connecting up to the fuselage cabling, details of which can be found in the relevant Aircraft Handbook.

**22.** No attention or servicing will normally be required during operation, provided that the unit is well secured on its anti-vibration

(A.L.90, Dec. 56)

mountings, that the Breeze connectors are tight and that the Dzus fasteners attaching the channels to the rack assembly are properly engaged.

#### SERVICING

23. Servicing should be carried out in accordance with the relevant servicing schedule but details given in the following paragraphs should be noted.

24. Channel units can be readily replaced by unscrewing the Dzus fasteners and unplugging the unit from the rack.

#### Mounting rack assembly

25. Corrosion may be removed from chassis or plugs and sockets (provided the part is not an electrical contact point) by using a stone, scraper, or fine emery cloth. Plugs or sockets must be recoated with insulating varnish (Stores Ref. 33B/938) over the affected areas. Chassis areas affected must be re-covered with "Celletch" primer to specification D.T.D.900 followed by two coats of matt black air-drying paint to D.T.D.314. Corrosion on contact points may be burnished off, using a highly polished thin section steel strip, care being taken not to move pins out of alignment.

26. To examine the internal parts of the rack assembly, unscrew the eighteen csk/hd. screws securing the socket mounting-plate to the chassis unit. Gently lift the plate until the wiring connected to the sockets on the plate prevents further lifting, then tilt the plate to one side to allow visual access to all parts of the internal wiring. If faulty wiring has to be replaced, and in consequence the P.V.C. coating has been disturbed, the affected area must be re-coated, so that insulation resistance is maintained and ingress of moisture prevented.

27. Electrical tests may be carried out, using a low voltage ohmmeter (1.5V), a 250-volt insulation resistance tester, and a universal impedance bridge or other capacity measuring device.

#### Warning . . .

*Before carrying out a 250V insulation test verify, by means of a low voltage ohmmeter, that there is no continuity between the points being tested.*

28. Insulation resistance between plug pins and chassis and between adjacent pins, not electrically connected, should not be less than 100 megohms, as measured with the 250-volt insulation resistance tester.

#### Note . . .

*Where a capacitor is shown connected to either point undergoing test, the applied voltage must not exceed the maximum working voltage of the capacitor.*

#### Functional continuity test

29. A continuity test may be carried out between all points shown electrically connected (fig. 7), using a low voltage (1.5V.) ohmmeter.

#### Capacitors

30. The capacitance should be measured at a frequency of 50 cycles to 200 cycles on a universal impedance bridge (or other capacity measuring device), between the following socket inserts (fig. 7):—

- (1) Socket Q, between inserts 9 and 10
- (2) Socket N, between inserts 3 and 8
- (3) Socket S, between inserts 3 and 8
- (4) Socket Q, between inserts 1 and 2

#### Resistors

31. The four 220-ohm resistors are to be within  $\pm 20$  per cent of their accorded value. Resistances can be measured between Breeze pins C and E of the plugs J, K, L and M (fig. 7).

#### Common control channel

32. To inspect this channel the dust-cover should first be removed. Corrosion on chassis or plug may be treated as in para. 25. To examine the internal parts of the channel the plate carrying the Pye plug at the base of the chassis can be unscrewed and separated as far as the wire-connections will allow. Wires which are broken or have their insulation covering damaged must be replaced. All P.V.C. coating removed must be re-applied.

33. Electrical tests on the channel may be carried out with the aid of a test rig constructed as in fig. 1A of App. 1, a low voltage (1.5V.) ohmmeter, a 250-volt insulation resistance tester and a 24V d.c. supply.

#### Warning . . .

*Before carrying out a 250V insulation test verify, by means of a low voltage ohmmeter, that there is no continuity between the points being tested.*

34. Electrical continuity should be tested between all points shown connected on the wiring diagram (fig. 8B). Insulation resistance is to be checked with the aid of a 250-volt insulation resistance tester between each Pye plug pin and the chassis. This resistance must not be less than 20 megohms after 15 seconds electrification in each case.

**RESTRICTED**

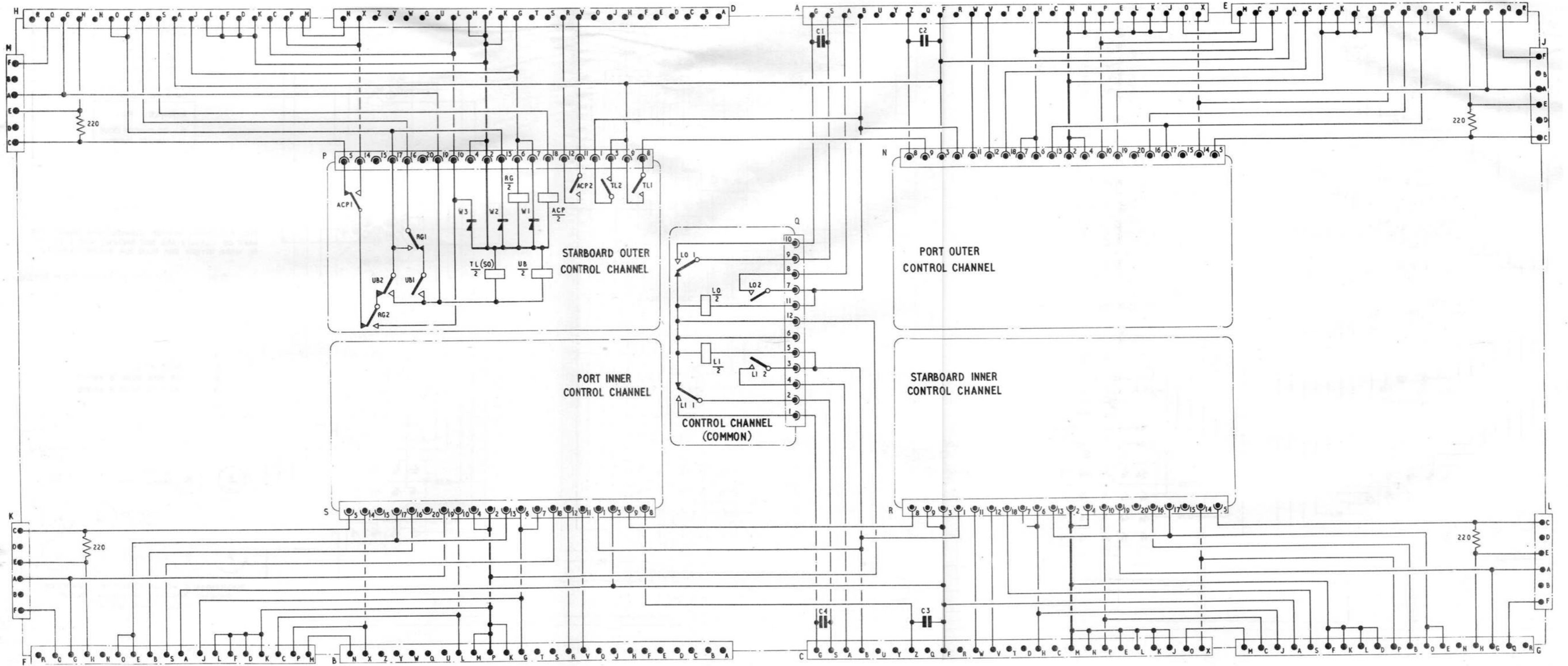

Fig.6

Theoretical circuit diagram  
RESTRICTED

Fig.6

(A.L.90, Dec. 56)

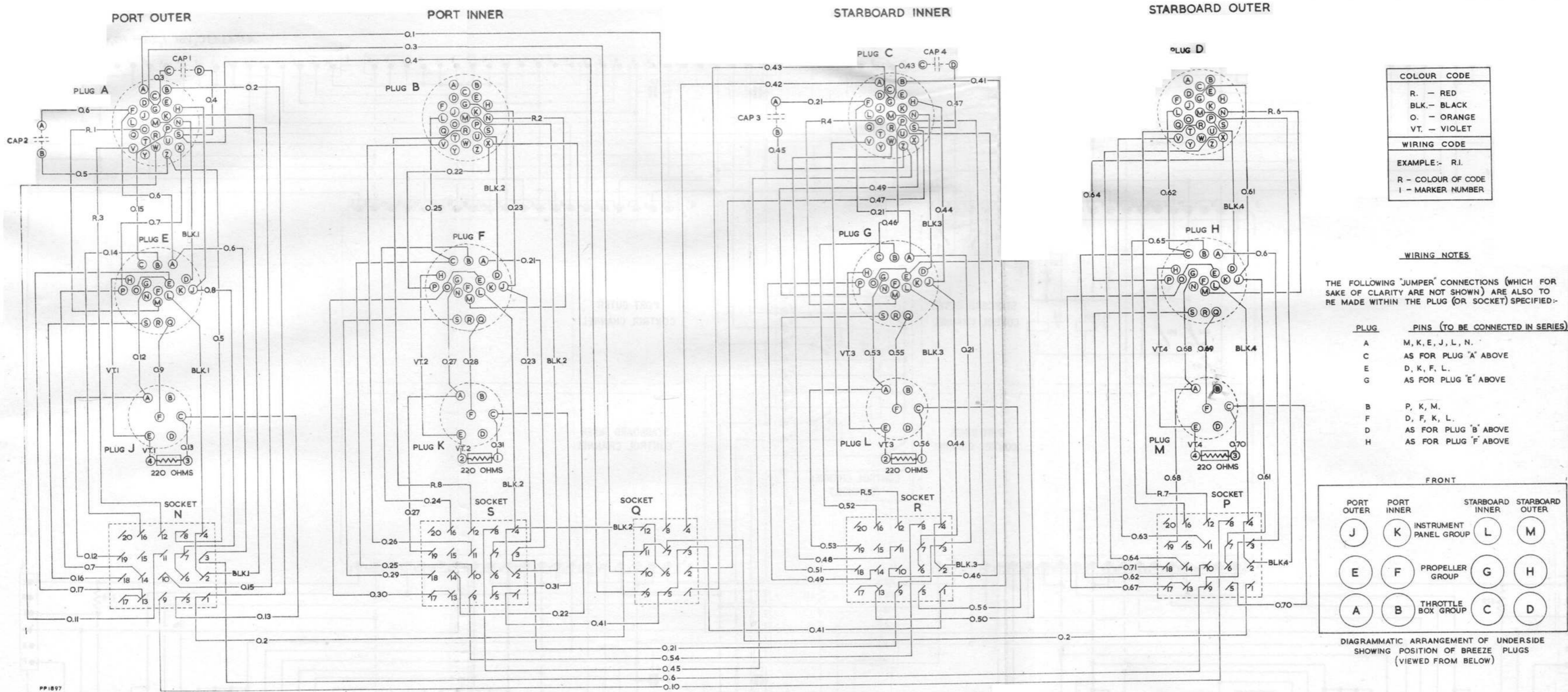

Fig. 7

Wiring diagram, mounting rack assembly  
**RESTRICTED**

Fig. 7

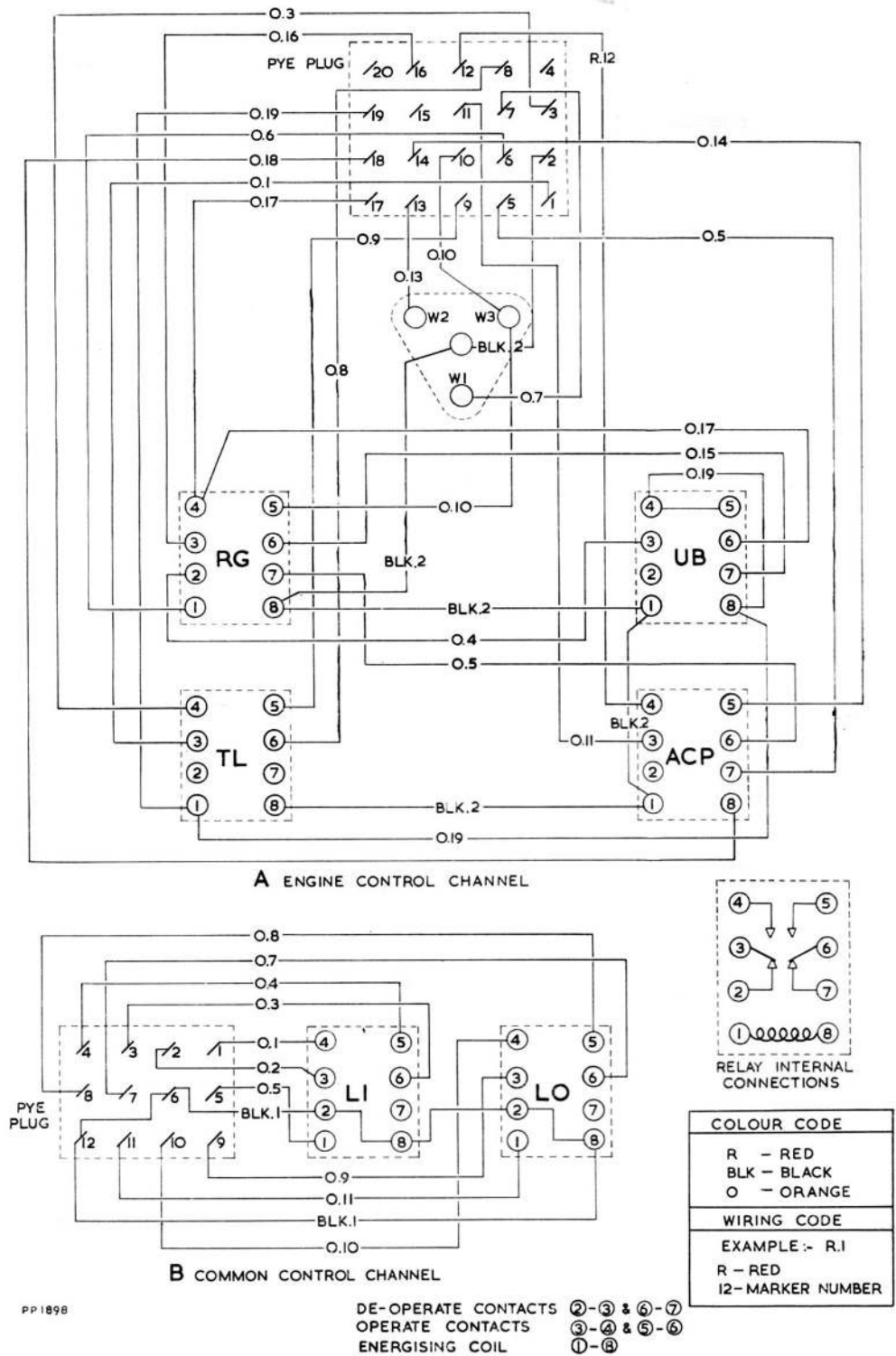

Fig. 8. Wiring diagram, engine and common control channels

(A.L.90, Dec. 56)

**RESTRICTED**

#### Functional test

**35.** With the channel unplugged from its parent rack and plugged into the test rig, manufactured according to fig. 1A of App. 1, switch ON main switch (lamps L1, L3 and L5 should light) and commencing with all remaining switches in the OFF position, carry out the functional tests in the order given in Table 1 of App. 1. The test is required to be repeated at least five times and should it prove unsatisfactory, a detailed examination must then be made to locate the faulty unit or units.

#### Relays

**36.** To examine the condition of a relay coil, its resistance may be checked at a temperature of 15 deg. C. This resistance is measured between Pye plug pins 5 and 12 for the LI relay, and between pins 11 and 12 for the LO relay (fig. 8B), and it should be 700 ohms  $\pm 5$  per cent, using a low voltage ohmmeter (1.5V). The relays fitted to the control channels are sealed and non-adjustable, and must be renewed should they prove faulty.

**37.** To fit a new relay, the dust-cover and channel base-plate must first be removed as detailed in para. 32. The P.V.C. coating must then be cut away in the required area on the underside of the relay base, and the thin-nuts, washers and securing strip removed from the two holding down studs. The relay can then be unplugged. After the new relay has been plugged in and secured, as above, the P.V.C. coating must be re-applied in the affected area.

#### Engine control channel

**38.** General inspection can be carried out as detailed in para. 32, and any corrosion or wire damage treated as described.

**39.** Electrical tests can be made with the aid of a test rig arranged and connected as shown in fig. 1B of App. 1; a low voltage (1.5V) ohmmeter; a 250-volt insulation resistance tester and a 24V d.c. supply.

#### Warning . . .

*Before carrying out a 250V insulation test verify, by means of a low voltage ohmmeter, that there is no continuity between the points being tested.*

**40.** Electrical continuity is to be tested between all points shown connected on the wiring diagram (fig. 8A). Insulation resistance should be checked with a 250-volt insulation resistance tester, between each Pye plug pin and the chassis frame. This resistance must not be less than 20 megohms, after 15 seconds electrification in each case.

#### Functional test

**41.** With the channel unplugged from its parent rack and plugged into the test rig, manufactured to accord with fig. 1B of App. 1, switch ON the main switch, with the remaining switches positioned as on the illustration. The functional tests may then be carried out in the order given in Table 2 of App. 1. The test should be repeated at least five times, and if it proves unsatisfactory, a further detailed examination must be made to identify the faulty unit or units.

#### Relays

**42.** The coil resistance of each relay should be checked at a temperature of +15 deg. C. and can be measured as follows:—

(1) Pye plug pins 6 and 2, resistance 700 ohms  $\pm 5$  per cent (relay RG)

(2) Pye plug pins 18 and 2, resistance 700 ohms  $\pm 5$  per cent (relay ACP).

(3) Pye plug pins 19 and 2, resistance 350 ohms  $\pm 5$  per cent (relays TL, UB)

A low voltage (1.5V) ohmmeter should be used. The relays fitted to this control channel are sealed and non-adjustable, and must be renewed should they prove faulty. The renewal of a relay is described in para. 37.

#### Rectifiers

**43.** Each of the three germanium junction rectifiers may be examined externally on removal of the channel dust-cover. Should their appearance indicate damage or overheating, they can easily be removed by unscrewing their upper terminal nuts, also the 6 B.A. centre screw, and then removing the connecting plate. Each rectifier can be removed individually, once the plate has been lifted.

**44.** Rectifiers may be tested in the following manner:—

(1) To check for reverse current flow, a voltage of 60V d.c. should be applied across the terminals, the positive pole of the supply being connected to the larger 4 B.A. terminal of the rectifier. At room temperature the resulting current must not exceed 0.25 mA.

(2) To check for forward current flow, a current of 200 mA should be passed through the rectifier in the forward direction, i.e., the supply positive should be connected to the smaller 6 B.A. terminal and the supply negative to the larger 4 B.A. terminal. The volts drop across the rectifier under these conditions must not exceed 0.7 volts at 20 deg. C.

# Appendix I

## TEST RIGS

### LIST OF CONTENTS

|                        |     |     |     |     |     |              |   |
|------------------------|-----|-----|-----|-----|-----|--------------|---|
| <i>Introduction...</i> | ... | ... | ... | ... | ... | <i>Para.</i> | 1 |
|------------------------|-----|-----|-----|-----|-----|--------------|---|

### LIST OF TABLES

|  |     |   |  |     |   |
|--|-----|---|--|-----|---|
| <i>Testing sequence for common control channel</i> | ... | 1 | <i>Testing sequence for engine control channel</i> | ... | 2 |
|--|-----|---|--|-----|---|

### LIST OF ILLUSTRATIONS

|                                 |     |     |     |     |             |   |
|---------------------------------|-----|-----|-----|-----|-------------|---|
| <i>Arrangement of test rigs</i> | ... | ... | ... | ... | <i>Fig.</i> | 1 |
|---------------------------------|-----|-----|-----|-----|-------------|---|

**Introduction**

1. The test rigs referred to in Chap. 1 are items which may be made up locally for testing the components of the control channel unit. The layout of the rig for the common control channel is shown at A of fig. 1, and

that for the engine control channel at B.

2. Table 1 indicates the testing sequence for the common control channel (*Chap. 1, para. 35*), and Table 2 that for the engine control channels (*para. 41*).

**TABLE 1**  
**Testing sequence for common control channel**

| Switch to be operated | Switch position | Correct lamp indications |    |    |    |    |
|-----------------------|-----------------|--------------------------|----|----|----|----|
|                       |                 | L1                       | L2 | L3 | L4 | L5 |
| —                     | —               | *                        | —  | *  | —  | *  |
| S1                    | ON              | *                        | *  | —  | —  | *  |
| S2                    | ON              | *                        | *  | *  | —  | *  |
| S3                    | ON              | *                        | *  | *  | *  | —  |
| S4                    | ON              | *                        | *  | *  | *  | *  |
| All †                 | OFF             | —                        | —  | —  | —  | —  |

\*=lamp lit; -=lamp out; †=all includes main switch

**Note . . .**

*Switches must be operated in the sequence shown.*

**RESTRICTED**

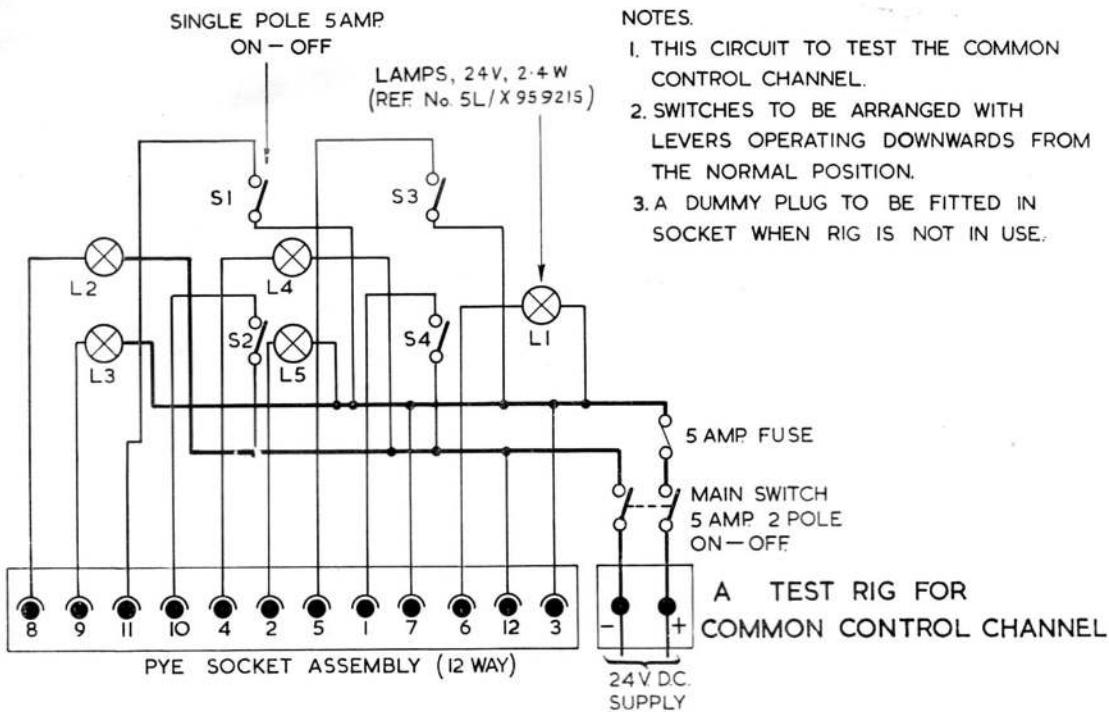

NOTES.

1. THIS CIRCUIT TO TEST THE COMMON CONTROL CHANNEL.
2. SWITCHES TO BE ARRANGED WITH LEVERS OPERATING DOWNWARDS FROM THE NORMAL POSITION.
3. A DUMMY PLUG TO BE FITTED IN SOCKET WHEN RIG IS NOT IN USE.

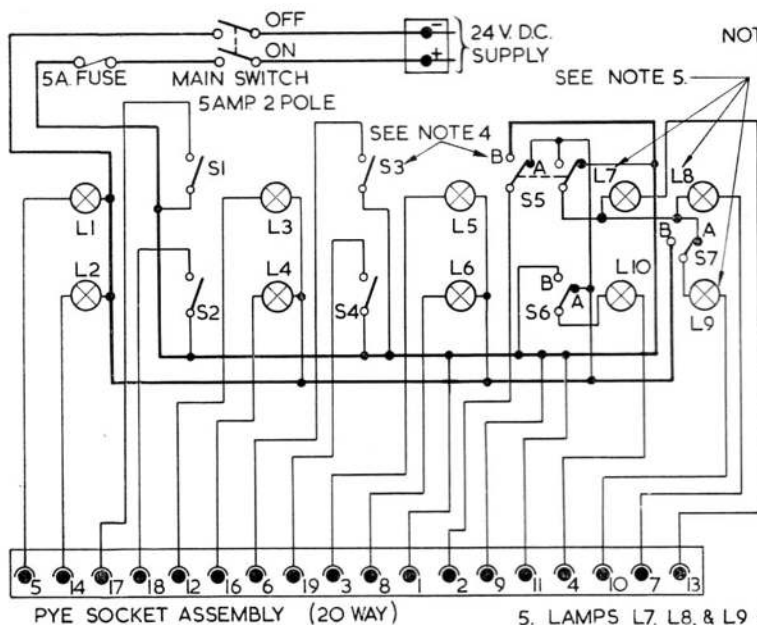

NOTES.

1. SWITCHES TO BE ARRANGED WITH LEVERS OPERATING DOWNWARDS FROM NORMAL POSITION.
2. A DUMMY PLUG SHOULD BE FITTED WHEN RIG IS NOT IN USE.
3. SWITCH S5 TO BE A 5AMP DOUBLE POLE CHANGEOVER, AND SWITCHES S6 & S7 TO BE 5 AMP SINGLE POLE CHANGEOVERS. THE REMAINDER ARE 5AMP SINGLE POLE ON OFF SWITCHES.
4. SWITCHES S3 & S5 TO BE MECHANICALLY INTERLOCKED, SO THAT S3 CANNOT BE CLOSED WHEN S5 IS IN POSITION 'B'.
5. LAMPS L7, L8, & L9 ARE TO BE 50V, 5W LAMPS (5L/X959220). UNDER NO CIRCUMSTANCES MUST 24V LAMPS BE USED. THE 50V LAMP FILAMENTS WILL GLOW JUST SUFFICIENTLY FOR DETECTION PURPOSES. 24V LAMPS (REF. 5L/X959215) MAY BE USED FOR LAMPS OTHER THAN THOSE MENTIONED.

B TEST RIG FOR ENGINE CONTROL CHANNEL

Fig. 1. Arrangement of test rigs

RESTRICTED

**TABLE 2**  
**Testing sequence for engine control channel**

| Switch to be operated | Switch position | Correct lamp indications |    |    |    |    |    |    |    |    |     |
|-----------------------|-----------------|--------------------------|----|----|----|----|----|----|----|----|-----|
|                       |                 | L1                       | L2 | L3 | L4 | L5 | L6 | L7 | L8 | L9 | L10 |
| S1                    | ON              | *                        | —  | —  | —  | —  | —  | —  | —  | —  | —   |
| S2                    | ON              | —                        | *  | *  | —  | —  | —  | —  | —  | —  | —   |
| S3                    | ON              | —                        | —  | *  | *  | —  | —  | —  | —  | —  | —   |
| S7                    | Pos. B          | —                        | —  | *  | *  | —  | —  | —  | —  | *  | —   |
| S7                    | Pos. A          | —                        | —  | *  | *  | —  | —  | —  | —  | —  | —   |
| S4                    | ON              | —                        | —  | *  | *  | *  | *  | —  | —  | —  | —   |
| S4                    | OFF             | —                        | —  | *  | *  | *  | *  | —  | —  | —  | —   |
| S3                    | OFF             | —                        | —  | *  | *  | *  | *  | —  | —  | —  | —   |
| S1                    | OFF             | —                        | —  | *  | —  | —  | —  | —  | —  | —  | —   |
| All †                 | OFF             | —                        | —  | —  | —  | —  | —  | —  | —  | —  | —   |
| S6                    | Pos. B          | —                        | —  | —  | —  | —  | —  | —  | —  | —  | —   |
| S6                    | Pos. A          | —                        | —  | —  | —  | —  | —  | —  | —  | —  | —   |
| S5                    | Pos. B          | —                        | —  | —  | —  | —  | —  | *  | *  | *  | —   |
| S5                    | Pos. A          | —                        | —  | —  | —  | —  | —  | —  | —  | —  | —   |
| S6                    | Pos. B          | —                        | —  | —  | —  | —  | —  | —  | —  | —  | —   |
| All                   | OFF or pos. A   | —                        | —  | —  | —  | —  | —  | —  | —  | —  | —   |

\*=lamp lit; —=lamp out; †=does not include main switch

**Notes . . .**

- (1) L7, L8 and L9 only glow weakly when operated.
- (2) Switches must be operated in the sequence shown.

**RESTRICTED**

(A.L.90, Dec. 56)

This file was downloaded  
from the RTFM Library.

Link: [www.scottbouch.com/rtfm](http://www.scottbouch.com/rtfm)

Please see site for usage terms,  
and more aircraft documents.

