

Now 113D-07121-1

Chapter 15

MOTOR OVERLOAD PROTECTION UNITS (AVRO)

LIST OF CONTENTS

	<i>Para.</i>		<i>Para.</i>
<i>Introduction</i>	1	<i>Servicing</i>	8
<i>Description</i>	2	<i>Testing</i>	9
<i>Operation</i>	3		

LIST OF ILLUSTRATIONS

	<i>Fig.</i>		<i>Fig.</i>
<i>Motor overload protection unit</i> 26DC/12656	1	<i>Circuit diagram of 26DC/12656...</i>	3
<i>Plug-in unit</i>	2	<i>Circuit diagram of 26DC/14704...</i>	4

LIST OF APPENDICES

	<i>App.</i>
<i>Standard serviceability test</i>	A

LEADING PARTICULARS

Motor Overload Protection Unit (20/V10493)	Ref. No. 26DC/14704
<i>Dimensions</i>	
<i>Height</i>	2.5 ins.
<i>Width</i>	3.4 ins.
<i>Length</i>	4.0 ins.
<i>Weight</i>	1.25 lbs.
<i>Continuous rating</i>	30A per phase
<i>Forward leakage current at 29 volts</i>	5mA at 25 deg. C
<i>Supply voltage</i>	28V. d.c. and 115v. 400 c/s 3 phase
Motor Overload Protection Unit (62/V11313)	Ref. No. 26DC/12656
<i>Dimensions</i>	
<i>Height</i>	2.5 ins.
<i>Width</i>	3.75 ins.
<i>Length</i>	4.0 ins.
<i>Weight</i>	1.18 lbs.
<i>Continuous rating</i>	50A per phase
<i>Forward leakage current at 29 volts</i>	3mA
<i>Supply voltage</i>	28V. d.c. and 115V. 400 c/s 3 phase
Plug-in unit (132/V11313)	
<i>Dimensions</i>	1.0 in. × 1.0 in. × 4.0 ins.
<i>Weight</i>	4 ozs.

RESTRICTED

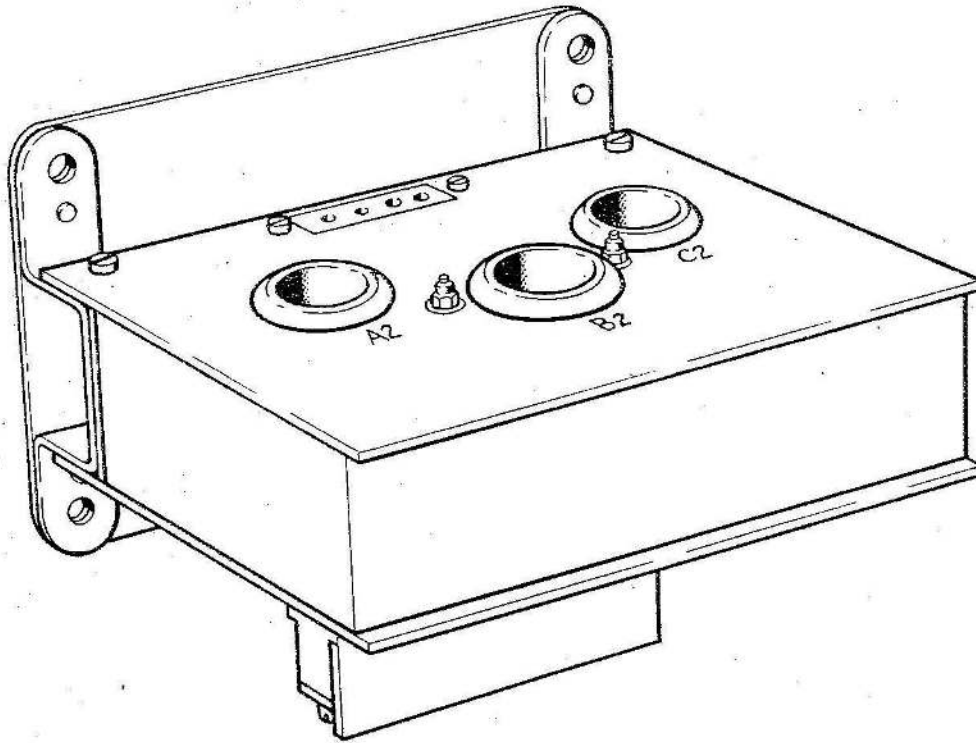

Fig. 1. Motor overload protection unit 26DC/12656

Introduction

1. These units give protection against overloads and unbalanced conditions during starting and running of 3 phase induction motors. The two units are similar in operation, the only difference being, that the Plug-in Unit circuit is incorporated in the protection unit (26D/14704).

DESCRIPTION

2. All the components are mounted within an aluminium case and potted in Araldite 'D' (fig. 1). The cables of the three phase supply to the motor, pass through three holes in the top of the unit, two of the holes C2 and A2 being the centres of the current transformers. The Plug-in Unit, plugs into the top of the Protection Unit (26DC/12656) and comprises of a four layer diode, a capacitor and two resistors, all the components are mounted within the plug and potted in Silcoset 101 (fig. 2).

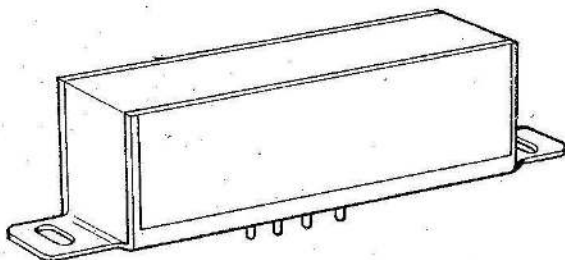

Fig. 2. Plug-in unit

OPERATION

3. The current flowing in the supply lines induces a current in the secondary of the transformers CT.1 and CT.2 (fig. 3). This is rectified by D1 and D2 and produces a potential across resistors R3 and R7, which is applied to resistor R4 in parallel with capacitor C2, so that the highest potential will predominate. The resultant is applied to the four layer diode, via the network R1, R2 and C1. This network will delay the potential build-up, to prevent operation on transient overload conditions during starting and running.

4. The four layer diode will not conduct until a predetermined potential is reached, therefore under normal running conditions, the potential across resistor R6 will be negligible, since there will be no current flow through resistor R9, and the SCR will not conduct.

5. On overload condition, the output of the current transformers will increase, causing an increase in potential and the four layer diode will conduct. Current will then flow through resistor R9 resulting in a voltage drop across it, this will produce a potential across R6 and the SCR. The SCR will then conduct and sufficient current will flow to energize the trip coil of the associated contactor via terminal 1.

RESTRICTED

This file was downloaded
from the RTFM Library.

Link: www.scottbouch.com/rtfm

Please see site for usage terms,
and more aircraft documents.

