

## Chapter 1

### MICRO SWITCHES, A.M., BURGESS AND PYE SERIES

#### LIST OF CONTENTS

	<i>Para.</i>
<i>Introduction</i> ... ..	1
<b>Description</b>	
<i>Air Ministry micro switches</i> ... ..	4
<b>Servicing</b> ... ..	8

#### LIST OF ILLUSTRATIONS

	<i>Fig.</i>		<i>Fig.</i>
<i>Micro switch, Type 1</i> ... ..	1	<i>Terminal and contact arrangements</i>	
<i>Sectional view of micro switch, Type 4A</i> ... ..	2	(Types 1, 1A, 4 and 4A) ... ..	3

#### LIST OF APPENDICES

	<i>App.</i>		<i>App.</i>
<i>Micro switches, Air Ministry series</i> ... ..	1	<i>Micro switches, Burgess series</i> ... ..	3
<i>Micro switches, Pye series</i> ... ..	2	<i>Micro switchettes and auxiliary actuators</i> ... ..	4

#### Introduction

1. There are various types of micro switch in service. All serve a similar purpose, and are in general suitable for inductive loads of 5 amp. at 30 volts, but they differ in external dimensions and actuating mechanism, and consequently are not necessarily interchangeable.

2. The metal-cased micro switches, e.g. A.M. Types 1A and 4A, are suitable for fitting in exposed positions on an aircraft, or in positions where they would be subject to extreme shock, such as on the alighting gear.

3. This chapter is concerned mainly with the Air Ministry types, but various Burgess and Pye switches are covered in Appendices to this chapter.



Fig. 1. Micro switch, Type 1

RESTRICTED

## DESCRIPTION

### Air Ministry micro switches

4. There are two types of Air Ministry micro switch, namely Types 1 and 4, and also a metal-cased version of each, known respectively as Types 1A and 4A. Dimensional and other details are listed under Leading Particulars of Appendix 1 to this Chapter.

5. These switches are all similar externally, a typical switch being shown in fig. 1 and a sectional view of the Type 4A is given in fig. 2. When the plunger is depressed, the central arm of the spring is moved beyond its equilibrium position, and the spring system moves over with a snap action to the lower contact or contacts.

6. When the plunger is depressed or released the appropriate contacts should make simultaneously at the "click" point. The breaking contacts may, however, break at a maximum of 0.008 in. plunger movement before the

"click" point, either on depression or release of the plunger. The terminal and contact arrangements are shown in fig. 3.

7. The switches have a rubber cowl fitted over the plunger, and secured with Titebond 22 (*Ref. No. 33C/1302*) thus making the connection waterproof and oilproof. The cowl has a slight lifting movement, which gives 0.03 in. free movement of the plunger before the trip point. The overtravel is 0.19 in., giving a total operating travel of approximately 0.22 in. The pressure required to operate the switch is not more than 2 lb. for Types 1 and 1A and not more than 4 lb. for Types 4 and 4A, while the pressure at the moment of release is not less than 1 lb.

## SERVICING

8. Little servicing is possible, apart from a general inspection for freedom from damage and a check for correct operation. Where necessary, the plunger may be lubricated with grease XG-275.

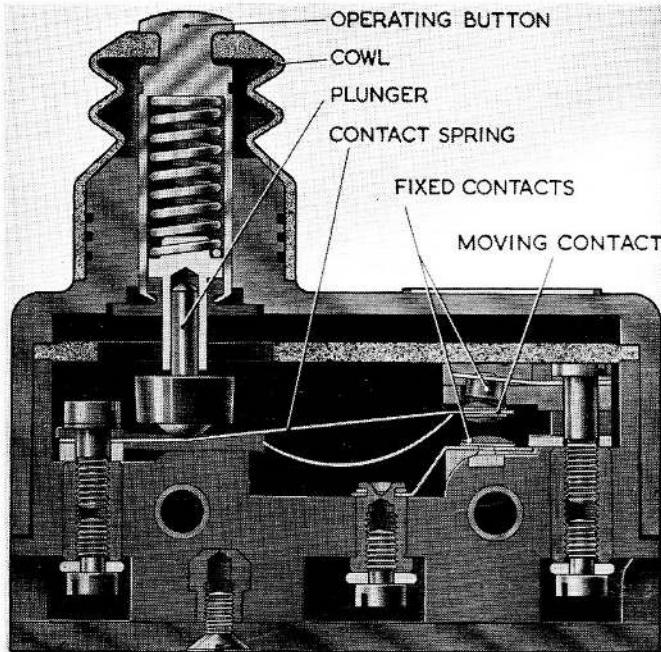
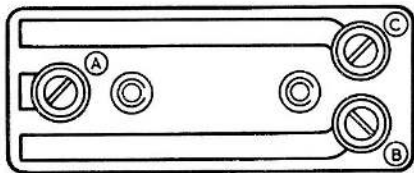
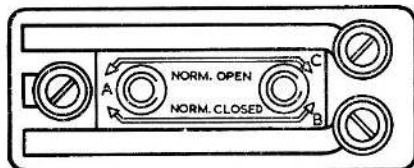

Fig. 2. Sectional view of micro switch, Type 4A

RESTRICTED



TYPE 1



TYPE 1A

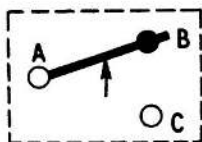
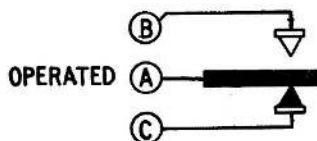
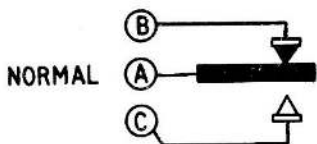

TYPES 1 AND 1A

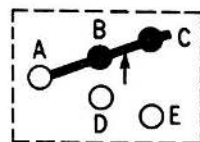
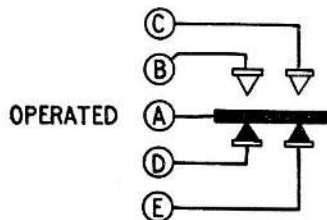
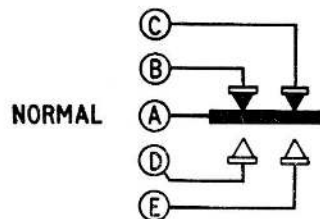
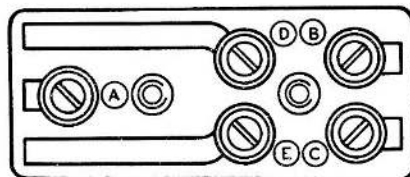

TYPES 4 AND 4A

Fig. 3. Terminal and contact arrangements (Types 1, 1A, 4 and 4A)

RESTRICTED

## Appendix 1

### MICRO SWITCHES, AIR MINISTRY SERIES

#### LEADING PARTICULARS

Table 1

Type	Ref. No.	Type of plunger	No. of terminals	Contacts connected	
				Normal position	Operated position
1 1A (metal-cased) (Burgess BZ 38H) (Pye 430)	5CW/2126	long	3	A to B	A to C
	5CW/4638	long	3	A to B	A to C
4	5CW/3937	long	5	A to B and C	A to D and E
4A (metal-cased) (Burgess BZ 39H) (Pye 400)	5CW/4639	long	5	A to B and C	A to D and E

Table 2

Type	Approximate overall dimensions (in.)			Pre-travel (in.)	Overtravel (in.)
	Length	Width	Depth		
1 1A (metal-cased) (Burgess BZ 38H) (Pye 430)	2.08	0.8	2.04	0.03	0.19
	2.08	0.8	2.04	0.03	0.19
4	2.08	0.8	2.04	0.03	0.19
4A (metal-cased) (Burgess BZ 39H) (Pye 400)	2.08	0.8	2.04	0.03	0.19

RESTRICTED

## Appendix 2

### MICRO SWITCHES, PYE SERIES

#### LEADING PARTICULARS

Table 1

Type	Ref. No.	Type of plunger	No. of terminals	Contacts connected	
				Normal position	Operated position
83127	5CW/1972	short	3	A to B	A to (C, D)
83464	5CW/1970	long	5	A to B and E	A to (C, D)
83467	5CW/1971	long	3	A to B	A to (C, D)
83467	5CW/2081	long with mushroom head	3	A to B	A to (C, D)
400	5CW/4639	As A.M. Type 4A			
400S	5CW/6376	long	5	A to B and C	A to D and E
400S.PM	5CW/6248	long, panel mounted	5	A to B and C	A to D and E
401S	5CW/5982	long	3	A to B	A to C
430	5CW/4638	As A.M. Type 1A			
430S	5CW/6375	long	3	A to B	A to C

**Note . . .**

Where terminals C and D are shown in brackets they are permanently linked together within the switch.

Table 2

Type	Approximate overall dimensions (in.)			Pre-travel (in.)	Overtravel (in.)	Remarks
	Length	Width	Depth			
83127	2.07	0.8	1.07	0.02	0.06	Supersedes 83128-9 (5CW/1695)
83464	2.07	0.8	1.8	0.06	0.25	Supersedes 83463 (5CW/1697)

**RESTRICTED**

Table 2—contd.

Type	Approximate overall dimensions (in.)			Pre-travel (in.)	Overtravel (in.)	Remarks
	Length	Width	Depth			
83467 (5CW/1971)	2.07	0.8	1.8	0.06	0.25	Supersedes 83460-2 (5CW/1696)
83467 (5CW/2081)	2.07	0.8	1.8	0.06	0.25	
400S	2.08	0.8	2.005	0.01	0.2	
400S.PM	2.08	0.8	2.15	0.01	0.2	
401S	2.08	0.8	2.005	0.01	0.2	
430S	2.08	0.8	2.005	0.01	0.2	

1. In external appearance these switches are similar to the A.M. series. Though the mechanism of the Pye switches differs from that of the A.M. switches, the principle of operation is similar. When the plunger is

depressed, the spring snaps over and the moving contact is brought into engagement with the upper contact(s) instead of with the lower contacts as in the unoperated position.

RESTRICTED

## Appendix 3

## MICRO SWITCHES, BURGESS SERIES

## LEADING PARTICULARS

Table 1

Type	Ref. No.	Type of plunger	No. of terminals	Contacts connected	
				Normal position	Operated position
Mk. 2A/RR	5CW/1788	short	2	A to D	open
Mk. 2B/RR	5CW/1573	leaf-spring	2	A to D	open
Mk. 2C/RR	5CW/1723	long	2	A to D	open
Mk. 2A/GR	5CW/1771	short	2	open	A to D
Mk. 2B/GR	5CW/1790	leaf-spring	2	open	A to D
Mk. 2C/GR	5CW/1724	long	2	open	A to D
Mk. 2A/BR	5CW/1789	short	3	A to C	A to D
Mk. 2B/BR	5CW/1791	leaf-spring	3	A to C	A to D
Mk. 2C/BR	5CW/1792	long	3	A to C	A to D
Mk. 2A (Univ.)	5CW/1618	short	4	A to C	A to D & B
Mk. 2B (Univ.)	5CW/1617	leaf-spring	4	A to C	A to D & B
Mk. 2C (Univ.)	5CW/1591	long	4	A to C	A to D & B
Mk. 2GR/49	5CW/1599	special 0.70 in. spring	2	open	A to D
Mk. 4CR/7	5CW/5134	long	3	A to B	A to C
Mk. 4CR/260	5CW/5755	long	3	A to B	A to C
BY	5CW/6009	short	3	A to B	A to C
BZ 38H	5CW/9438275	As A.M. Type 1A			
BZ 38H/260	5CW/6629	long	3	A to B	A to C
BZ 39H	5CW/4639	As A.M. Type 4A			
C.05750	5CW/6672	long	5	A to B & C	A to D & E
C.05752	5CW/6575	long	3	A to B	A to C
CR/RLR	5CW/6684	Short depressed in normal position	3	COM to NC	COM to NO
CRW/2	5CW/5492	short	3	COM to NC	COM to NO
CYMR/176	5CW/5132	short		A to C	A to B
P3	5CW/1910	ball	3	A to C	A to B
VH1	5CW/7030	short	3	1 to 2	1 to 3

RESTRICTED

Table 2

Type	Approximate overall dimensions (in.)			Pre-travel	Overtravel	Remarks
	Length	Width	Depth			
Mk. 2A/RR	1.94	0.69	1.22	0.004	0.009	Supersedes RR
Mk. 2B/RR	2.45	0.69	1.38	0.25	0.5	Supersedes RRL 5CW/1119
Mk. 2C/RR	1.94	0.69	2.02	0.06	0.25	Supersedes RRS 5CW/1629
Mk. 2A/GR	1.94	0.69	1.22	0.004	0.009	Supersedes GR
Mk. 2B/GR	2.45	0.69	1.38	0.25	0.5	Supersedes GRL 5CW/2113
Mk. 2C/GR	1.94	0.69	2.02	0.06	0.25	Supersedes GRS 5CW/2079
Mk. 2A/BR	1.94	0.69	1.22	0.004	0.009	Supersedes BR 5CW/2182
Mk. 2B/BR	2.45	0.69	1.38	0.25	0.5	Supersedes BRL 5CW/1120
Mk. 2C/BR	1.94	0.69	2.02	0.06	0.25	Supersedes BRS
Mk. 2A (Univ.)	1.94	0.69	1.22	0.004	0.009	Supersedes D4387A, D4388A
Mk. 2B (Univ.)	2.45	0.69	1.38	0.25	0.5	Supersedes D4387B, D4388B
Mk. 2C (Univ.)	1.94	0.69	2.02	0.06	0.25	Supersedes D4387C, D4388C
Mk. 2GR/49	1.94	0.69	1.34	0.02	0.08	Supersedes GR49, 5CW/1565
Mk. 4CR/7	2.08	0.81	2.06	0.0065	0.18	Terminal screws
Mk. 4CR/260	2.084	0.815	2.04	0.04	0.18	Terminal screws
BY	2.08	0.8	1.21	0.01	0.005	Terminal screws
BZ 38H/260	2.084	0.815	2.04	0.05	0.18	Terminal screws
C.05750	2.08	0.8	2.025	0.05	0.18	Terminal screws
C.05752	2.08	0.8	2.025	0.05	0.18	Terminal screws
CR/RLR	2.96	0.69	1.6	0.19	0.15	Roller actuator Solder tags
CRW/2	2.96	0.69	1.37	0.375	0.18	Lever actuator Solder tags
CYMR/176	2.09	0.8	2.77	0.21	0.15	Roller actuator
P3	2.565	0.807	2.012	0.014	0.125	Terminal screws
VH1	1.565	0.5	1.0	Plunger may be depressed until flush with switch		High temperature Terminal screws

1. Most of these micro switches are similar to the Air Ministry types described in the main chapter. Some have special applications, e.g. Type CRW/2 has a lever actuator and is suitable where the available operating force is very limited. Types CRW/2 and P3 are shown in fig. 1 and 2 as representative types.

2. Auxiliary actuators, Type CB, a typical illustration of which appears in fig. 3, can be fitted to some micro switches to enable them to be operated by fast cams or slides on applications requiring low operating force, accurate repeat performance and generous over-travel.

RESTRICTED

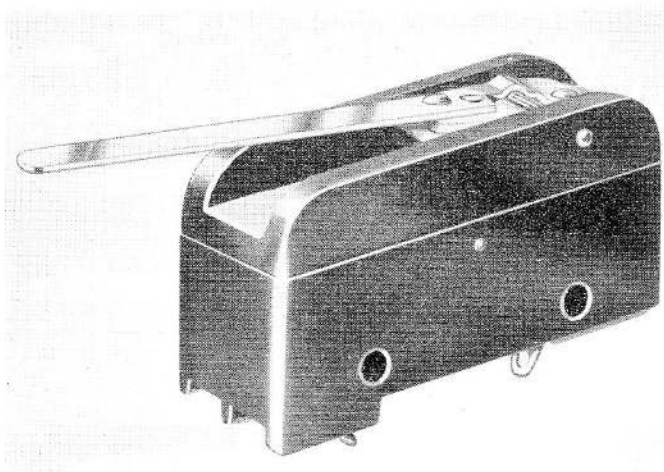

Fig. 1. Micro switch, Type CRW/2

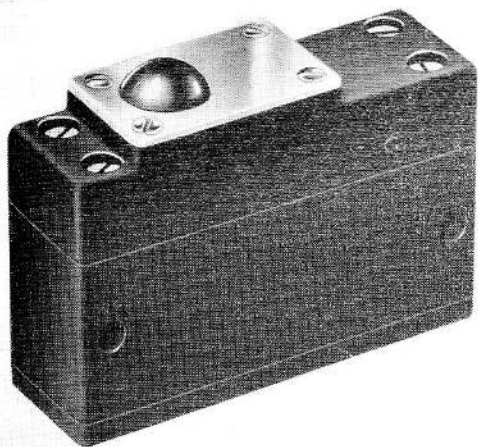

Fig. 2. Micro switch, Type P3

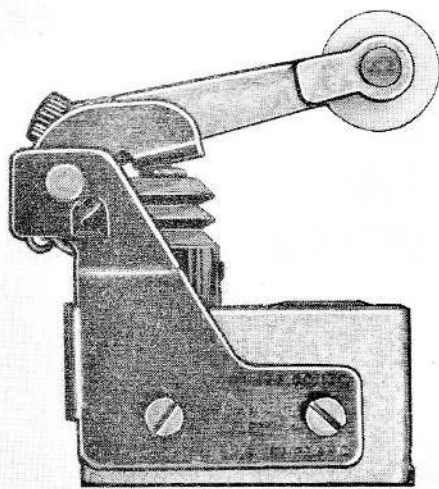

Fig. 3. Auxiliary actuator, Type CB539

RESTRICTED

3. The CB actuator is of the roller type, the earlier models having a case-hardened steel roller with an oil-retaining bronze bush, and an actuator arm of drop-forged steel. Later models are fitted with a nylon roller, cast stainless steel lever and a bracket of cadmium plated mild steel.

4. All CB actuator roller-arms are adjustable, relative to the switch-actuating lever, by

means of a slotted clamping bolt. The adjustment angle varying with the CB type number.

5. The CB actuator is suitable for fitting to the following micro switches:—Type 1A and 4A, Mk. 4CR/7, Mk. 4CR/260, C.15750, and C.05752.

**Table 3**  
**Auxiliary actuators**

Type	Ref. No.	Remarks
CB 539	5CW/7169	Actuator arm adjustable through 145 deg. by means of split sleeve, secured by an allen screw.

## Appendix 4

### MICRO SWITCHETTES AND AUXILIARY ACTUATORS

#### LEADING PARTICULARS

Table 1

Type	Ref. No.	No. of terminals	Contacts connected	
			Normal position	Operated position
V3	5CW/4615	3	COM to NC	COM to NO
V3 MLR	5CW/6621	3	1 to 2	1 to 3
V3/518	5CW/6676	3	COM to NC	COM to NO
2V3 QIT		6	1 to 2 1 to 2	1 to 3 1 to 3
V4-T1	5CW/6286	3	1 to 2	1 to 3
V4-T2	5CW/6900	3	1 to 2	1 to 3

Table 2

Type	Approximate overall dimensions (in.)			Pre-travel (in.)	Overtravel (in.)	Remarks
	Length	Width	Depth			
V3	1.38	0.416	1.0	0.074	0.032	Terminal screws
V3 MLR	1.565	0.5	1.23	0.035	0.015	Terminal screws Roller actuator
V3/518	1.38	0.416	1.0	0.05	0.032	Terminal screws
2V3 QIT	1.515	1.0	3.0	0.145	0.165	Terminal screws
V4-T1	0.78	0.22	0.56	0.03	0.005	Drilled terminals
V4-T2	0.78	0.22	0.56	0.03	0.005	Recessed terminals

**RESTRICTED**

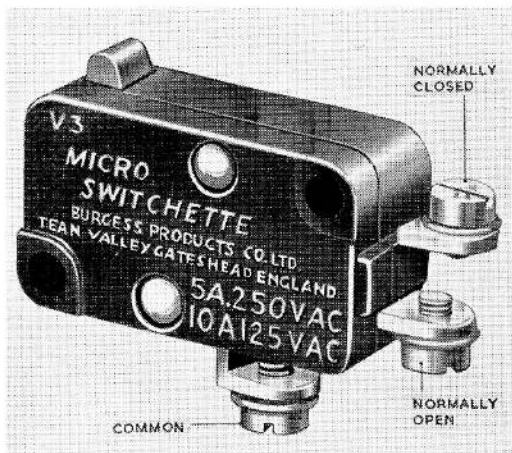

Fig. 1. Micro switchette, Type V.3

1. Micro switchettes are much smaller in volume and weight than the micro switches. Typical examples of their use will be found in aircraft trim control switches and as limit switches in certain aircraft landing lamps.

2. A typical switchette, Type V3, is shown in fig. 1. It has a rapid snap action and the

one-piece switching element is fitted with fine silver contacts.

3. Some switchettes incorporate an actuator, e.g. Type V3 MLR, while others, e.g. Types V3 and V4, can be fitted with auxiliary actuators. These auxiliary actuators, of stainless steel have been designed to enable the switchettes to be operated by cams, slides or other mechanical devices whose direction of movement are not coaxial with that of the switch plunger. The mounting holes of the auxiliary actuators align with those of the switchette. Fig. 2 illustrates auxiliary actuators fitted to a micro switchette, Type V3.

### Auxiliary Actuators

Type	Ref. No.	Lever
For use with switchette, Type V3		
V.L.1	—	plain leaf
V.L.R.1	Z519005	roller leaf
For use with switchette Type 4		
V.4.L.1	—	plain leaf
V.4.L.R.1	—	roller leaf

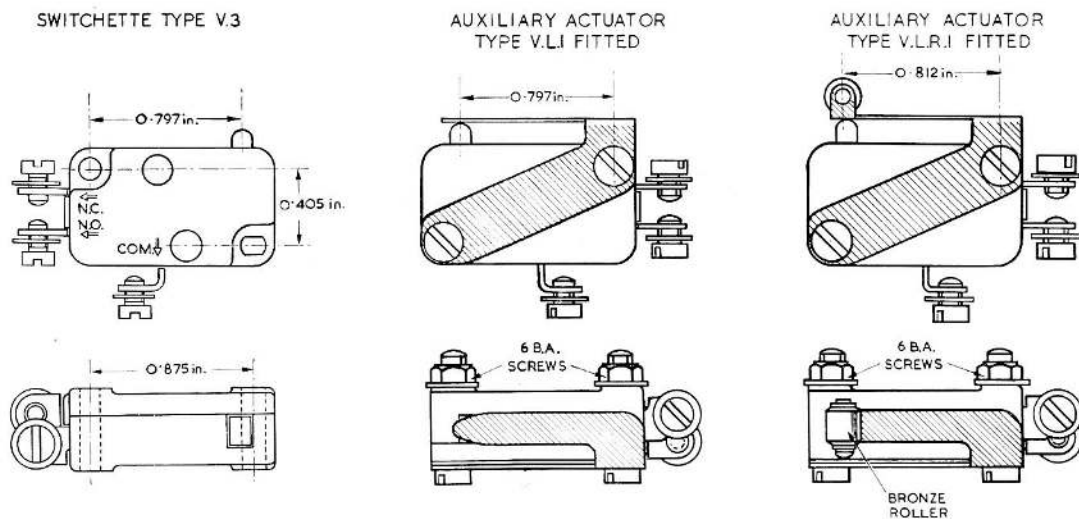

Fig. 2. Switch and actuator installation detail

This file was downloaded  
from the RTFM Library.  
Link: [www.scottbouch.com/rtfm](http://www.scottbouch.com/rtfm)

Please see site for usage terms,  
and more aircraft documents.

