

Chapter 10

LIMIT SWITCH, WESTERN, TYPE LS850

LIST OF CONTENTS

	Para.
Introduction	1
Description	2
Servicing	6

LIST OF ILLUSTRATIONS

	Fig.
Limit switch, Type LS850, Mk. 1	1
Sectional drawing of switch	2
Contact arrangement	3

LEADING PARTICULARS

Limit switch, Type LS850, Mk. 1	Stores Ref. 5CW/5146
Operating voltage	24 d.c.
Current rating	15 amp.
Overall dimensions—	
Length	1.55 in.
Width	1.45 in.
Height (excluding trip lever)	0.44 in.
Weight	$\frac{3}{4}$ oz.

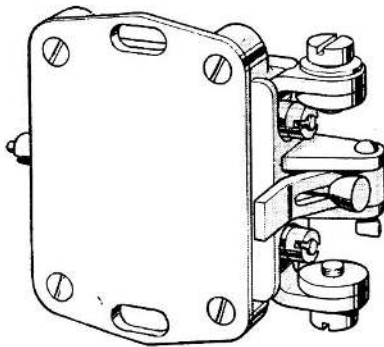

Fig. 1.
Limit switch, Type LS850, Mk. 1

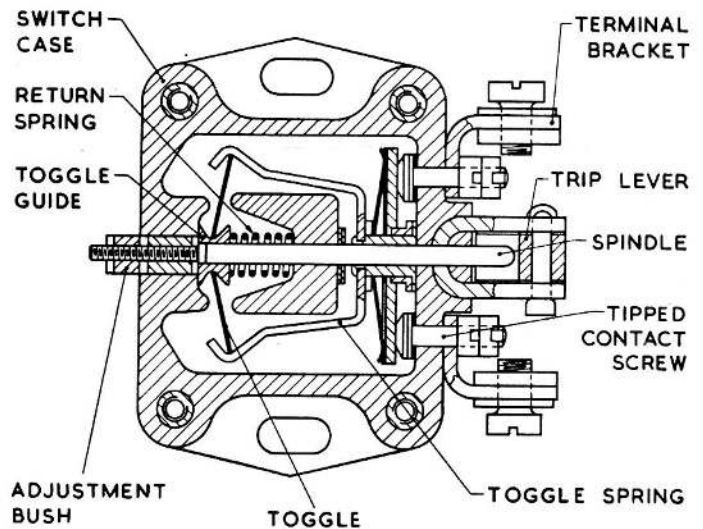
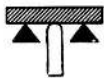
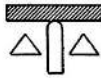

Fig. 2. Sectional drawing of switch



NORMAL



OPERATED

Fig. 3. Contact arrangement

Introduction

1. The limit switch, Type LS850, Mk. 1, is of the snap-action type, and may be used independently or incorporated in an actuator.

DESCRIPTION

2. This switch (*fig. 1 and 2*) is a single-pole, snap-action, normally closed type. The mechanism is contained in a black plastic case mounted on a duralumin base plate, and provided with two mounting slots.

3. The switch is operated by a central longitudinal spindle which carries a toggle guide connected through a toggle plate and spring to a moving contact bar. As the trip lever at the end of the operating shaft is moved outwards, i.e., to the right as shown

in *fig. 2*, the toggle plate is stressed until it passes top dead centre. At this point it snaps over to its new position, carrying the contact bar with it, and so opening the contacts.

4. The operating travel of the trip lever from its normal position is 0.12 in., with 0.16 in. overtravel; after the pressure is released, a spring returns the switch mechanism to its normal position.

5. The contact arrangement is shown in *fig. 3*; electrical connection is made by 6 B.A. terminal screws on terminal brackets at the trip lever end of the switch.

SERVICING

6. No servicing is permissible, apart from an inspection for freedom from damage and security of connections. The mechanism should snap over positively when the trip lever is actuated, and return to its original position when pressure on the trip lever is released; a faulty switch must be renewed.

This file was downloaded
from the RTFM Library.

Link: www.scottbouch.com/rtfm

Please see site for usage terms,
and more aircraft documents.

