

## Chapter 18

# NOSE WHEEL STEERING UNIT, ELECTRO HYDRAULICS, TYPE 7752

### LIST OF CONTENTS

	<i>Para.</i>	<i>Para.</i>
<i>Introduction</i> ....	1	<i>Functional test</i> .... 8
<b>Description</b> ....	2	<i>Insulation resistance test</i> .... 9
<i>Operation</i> ....	5	<i>Continuity test</i> .... 10
<b>Servicing</b> ....	7	

### LIST OF ILLUSTRATIONS

	<i>Fig.</i>	<i>Fig.</i>
<i>Nose wheel steering unit</i> ....	1	<i>Circuit diagram</i> .... 2

### LEADING PARTICULARS

#### Nose wheel steering unit, Type 7752

Distance between fixing centres:—

<i>Width</i> ....	5 in.
<i>Height (see fig. 1)</i> ....	3.5 in. and 4.95 in.

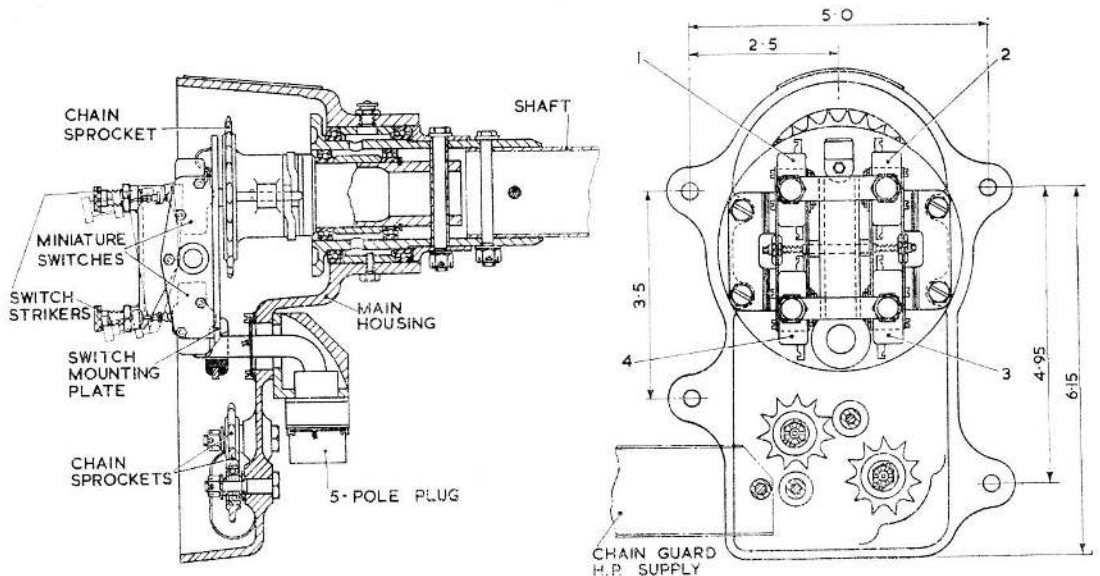

Fig. 1. Nose wheel steering unit

## Introduction

1. The nose wheel steering unit, Type 7752, incorporates four miniature switches which are operated from the steering handle and provide a control for the hydraulic jacks.

## DESCRIPTION

2. The unit (fig. 1) is connected by a shaft to the steering handle, and by a chain drive and mechanical linkage to the nose under-carriage.

3. Four miniature switches, Type LHE11-A1, are secured to a mounting plate in such a position that they are operated in sequence by spring-loaded strikers. A description of the miniature switches will be found in Sect. 1 of this Book.

4. Electrical connection is made to a 5-pole plug, the internal connections being as shown in the circuit diagram in fig. 2. The operating sequence is shown alongside; as the handle is turned in an anti-clockwise direction, switch 1 is operated first, then switch 2; as the handle is turned in a clockwise direction, switch 4 is operated, then switch 3.

## Operation

5. The four miniature switches control the solenoid valves in the steering selector, two of the valves being normally open and two normally closed. When the steering handle is in phase with the nose wheel, all the valves in the selector are de-energized. The normally-open valves connect both sides of the jacks to the low pressure side of the hydraulic system, enabling the under-

carriage to castor freely with hydraulic damping provided by the jacks.

6. A slight turn of the steering handle operates one of the switches, depending on the direction of rotation, thus energizing one of the normally-open valves and hydraulically locking the steering jacks so that the nose wheel cannot castor in a direction opposing the steering handle movement. A further turn of the handle in the same direction operates the second switch, which opens a normally-closed valve and connects the high-pressure side of the system to the jack, driving the nose wheel round in the same direction as the steering handle until the second switch is broken by the mechanical follow-up, leaving the first switch still made. The normally-closed valve is de-energized and the nose wheel is held hydraulically locked until, on release of the steering handle, the first switch is broken, the normally-open valve is de-energized and the nose wheel castors back to a neutral position.

## SERVICING

7. Little servicing is possible with this unit, apart from a general inspection for freedom from damage and security of connections. The following tests may be made.

## Functional test

8. (1) Check that the switches are so set that switch 4 operates before switch 3 when the handle is turned clockwise with respect to the sprocket, and that switch 1 operates before switch 2 when the handle is turned in an anti-clockwise direction. For each

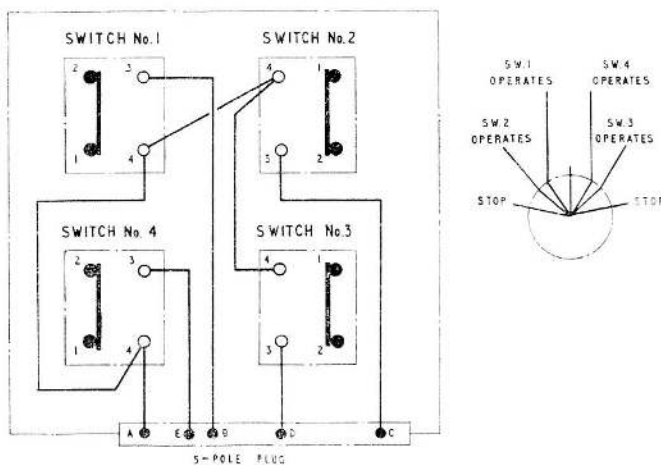

Fig. 2. Circuit diagram

RESTRICTED

direction of rotation the first switch should operate after  $2\frac{1}{2}$  deg. angular movement of the handle, and the second switch after a further  $\frac{1}{2}$  deg.

(2) Check that the handle will turn through 5 to 6 deg. with respect to the sprocket, both in an anti-clockwise and a clockwise direction.

(3) Check that the unit will self-centre to the mid position when rotated as in sub-para. (2), and that in the self-centred position all switches are released.

(4) Check that the switch strikers are not depressed until the switch has operated. Check also that, when the handle is rotated with respect to the sprocket until it is on its stop the strikers operating the switches can be further depressed.

(5) Check that the total backlash between the handle and the switches is less than 2 deg. angular movement of the handle.

#### **Insulation resistance test**

9. Check that the insulation resistance between any terminal and the frame is not less than 20 megohms when measured with a 250-volt insulation resistance tester.

#### **Continuity test**

10. Using a 250-volt insulation resistance tester and turning the steering handle clockwise, check that continuity is (1) A-E, (2) A-E, A-D. Turning the handle anti-clockwise, check that continuity is (1) A-B, (2) A-B, A-C.

This file was downloaded  
from the RTFM Library.

Link: [www.scottbouch.com/rtfm](http://www.scottbouch.com/rtfm)

Please see site for usage terms,  
and more aircraft documents.

