

Chapter 5

MECHANICALLY OPERATED SWITCH, TYPE 2B, No. 1 (ROTAX D8301)

LIST OF CONTENTS

	Para.		Para.
Introduction	1	Installation	9
Description	2	Servicing	10
Electrical connections	7	Insulation resistance tests	12
Operation	8		

LIST OF ILLUSTRATIONS

	Fig.		Fig.
Sectioned view of Type 2B, No. 1 switch	1	Diagram of internal connections	2

LEADING PARTICULARS

Switch, mechanically operated, Type 2B, No. 1 ...	Stores Ref. 5CW/4406
Voltage	28 volts
Current rating	10 amp.
Overall dimensions	
Length (including spindle)	2.624 in.
Diameter	2.5 in.
Weight	10.75 oz.
Fixing	4 holes 4 B.A.

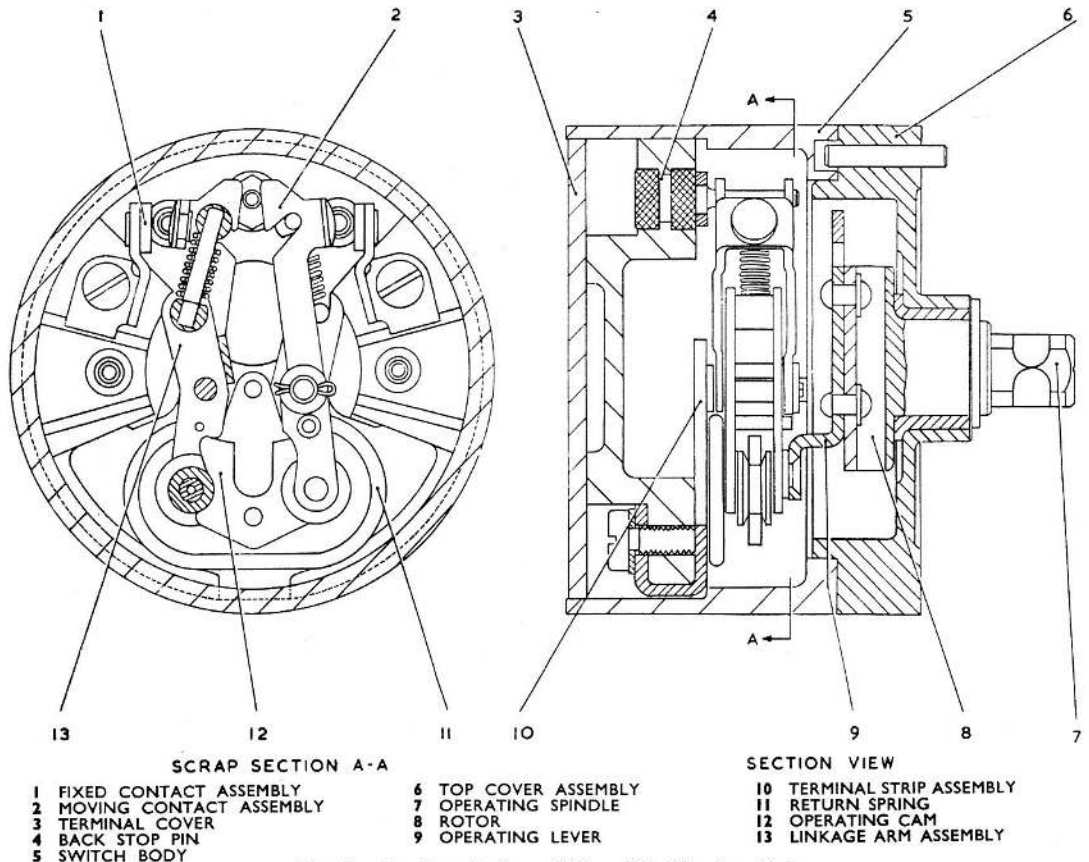

Fig. 1. Sectioned view of Type 2B, No. 1 switch

Introduction

1. The switch has been designed to make and break a 24 volt circuit with a maximum current rating of 10 amperes. It will give satisfactory operation up to 50,000 feet and in air temperatures of between -65 deg. C. and $+75$ deg. C.

DESCRIPTION

2. The unit comprises a cylindrical body 1.483 in. in length and 2.5 in. in diameter. On the base of the switch there are three terminals, No. 1 terminal being common to the two moving contacts of the switch. The switch (*fig. 1*) is operated by a rotor assembly comprising an operating spindle, rotor and lever. The operating spindle is secured to the rotor and protrudes through the top cover of the switch. Four grooves are machined on the periphery of the spindle to facilitate the fitting of an attachment for mechanical or manual operation.

3. The operating lever is secured to the base of the rotor by two rivets. The pin of the operating lever engages a cam which is pivoted on a pin attached to a terminal strip assembly fitted to the terminal carrier. The moving arms of the switch are each pivoted on a pin on the terminal strip which links them together electrically.

4. A linkage arm is connected through a compression spring to the moving contact arm, the whole forming a toggle system. Two identical toggle systems are used to provide the complete operating mechanism for the change-over switch.

5. When the operating spindle is turned, the pin carried on the operating lever moves one end of the linkage arm against the load of the return spring, and the opposite end of the linkage arm compresses the toggle spring until the load is sufficient to "over centre" the toggle system and move the contact arm to the contacts closed position with a snap action.

6. The two linkage arms are forced outwards by means of a spring action (which ensures that the contacts are open) when the spindle is in the "off" position.

Electrical connections

7. The three terminal connections at the base of the switch are 4 B.A. combined screw and washer type connections.

Operation

8. Turning the operating spindle 30 deg. in either direction closes contacts 1 and 2 or 1 and 3.

INSTALLATION

9. The unit may be mounted in any position. The overall length, including the spindle, is 2.624 in. Four mounting holes tapped 4 B.A. are provided in the top cover and are spaced on a 2.187 in. pitch circle diameter.

SERVICING

10. When this unit has been correctly installed and operated, it requires little attention in service. If the unit operates satisfactorily, it may be assumed serviceable for continued use.

11. A visual inspection should be made periodically to ensure that the unit is not damaged physically. Inspect the mechanism and if there is any sign of damage remove the unit and fit a new one in its place.

Insulation resistance tests

12. Insulation resistance tests should be applied to the unit, provided that it is accessible and can be isolated from its circuit. Using a 250 volt insulation resistance tester, the insulation resistance must be at least 2 megohm between the following points:—

- (1) All terminals and frame of switch.
- (2) Terminal 1 and terminal 2, with switch in the "off" position.
- (3) Terminal 2 and terminal 3, with switch in the "off" position.
- (4) Terminal 3 and terminal 1, with switch in the "off" position.

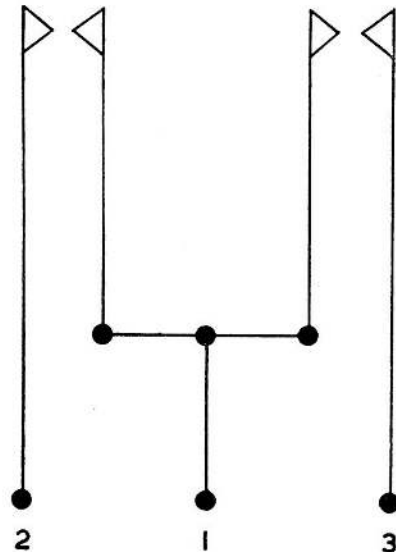

Fig. 2. Diagram of internal connections

RESTRICTED

This file was downloaded
from the RTFM Library.
Link: www.scottbouch.com/rtfm

Please see site for usage terms,
and more aircraft documents.

