

Chapter 9

LIMIT SWITCH, WESTERN, TYPE LS561

LIST OF CONTENTS

	Para.
Introduction	1
Description	2
Servicing	5

LIST OF ILLUSTRATIONS

	Fig.
Limit switch, Type LS561, Mk. 6	1
Sectional drawing of switch	2
Contact arrangement	3

LEADING PARTICULARS

Limit switch, Type LS561, Mk. 6	Stores Ref. 5CW/4643
Operating voltage	24 d.c.
Current rating	15 amp.
Temperature limits... ..	+90 deg. C to -55 deg. C
Overall dimensions—	
Length	1.675 in.
Width	1.3 in.
Height (excluding trip lever)	0.6375 in.
Weight	$\frac{3}{4}$ oz.

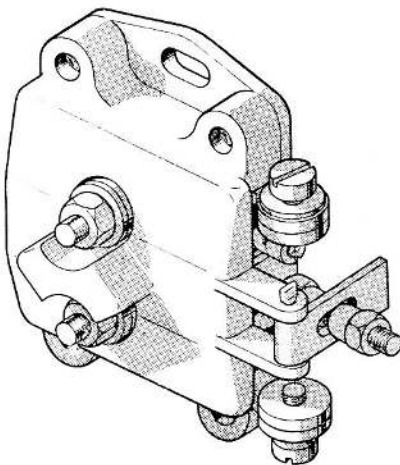

Fig. 1. Limit switch, Type LS561, Mk. 6

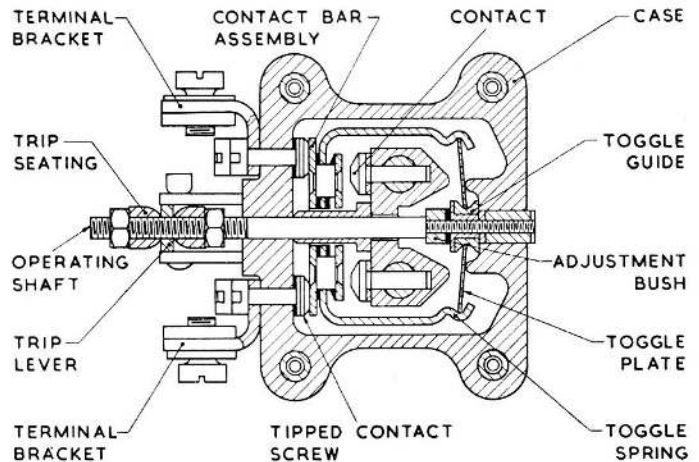

Fig. 2. Sectional drawing of switch

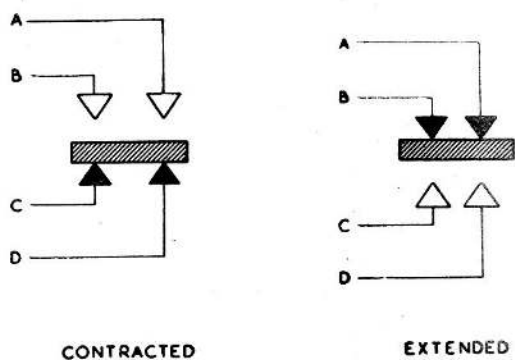

Fig. 3. Contact arrangement

Introduction

1. The limit switch, Type LS1761, Mk. 26, is of the snap-action type, and is operated by a trip lever 0.48 in. long. One application is as the filament switch in a landing lamp.

DESCRIPTION

2. This switch (*fig. 1 and 2*) is a double-pole, snap-action, change-over type. The mechanism is contained in a black plastic case mounted on a duralumin base plate, and provided with two mounting slots.

3. The switch is operated by a central longitudinal spindle which carries a toggle guide connected through a toggle plate and spring to a moving contact bar assembly. As the trip lever at the end of the operating shaft is moved outwards, i.e., to the left as shown in *fig. 2*, the toggle plate is stressed until it passes top dead centre. At this point it snaps over to its new position, carrying the contact bar assembly with it, so breaking contacts C and D and making contacts A and B. After the pressure is released, a spring returns the switch mechanism to its normal position.

4. Terminal brackets at the trip lever end of the switch carry 10 B.A. terminal screws for contacts C and D, and on the top of the switch are 6 B.A. terminal nuts for contacts A and B. The contact arrangement is shown in *fig. 3*.

SERVICING

5. No servicing is permissible, apart from an inspection for freedom from damage and security of connections. The mechanism should snap over positively when the trip lever is actuated, and a faulty switch must be renewed.



This file was downloaded from the RTFM Library.

Link: www.scottbouch.com/rtfm

Please see site for usage terms, and more aircraft documents.

