

## Chapter 10

### MAGNETIC RELAY SWITCH, TYPE T2

#### LIST OF CONTENTS

	Para.		Para.
Introduction...	1	Testing	
Description	2	Closing voltage ...	5
Installation	3	Drop-out voltage ...	6
Servicing ...	4	Contact resistance ...	7
		Insulation resistance ...	8

#### LIST OF ILLUSTRATIONS

	Fig.		Fig.
Magnetic relay switch, Type T2 ...	1	Terminal arrangement ...	3
Sectional view of switch ...	2		

#### LEADING PARTICULARS

Type T2	...	Stores Ref. 5CW/4621
Operating voltage	...	24
Intermittent rating	...	600 amp.
Dimensions	...	3 in. x 2.8 in. x 4 in.

**DSGAviation**

www.dsgaviation.co.uk

mail@dsgaviation.co.uk

#### Introduction

1. The magnetic relay switch Type T2, supersedes the Type J, and is suitable for remote control for engine starting and other short-rated heavy duties. It is intermittently rated for currents up to 600 amp.

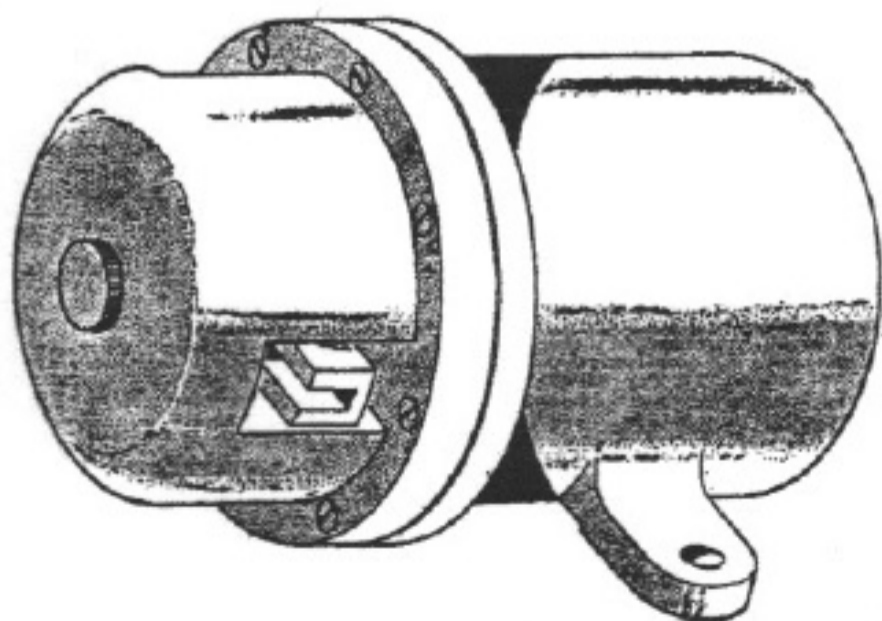

Fig. 1. Magnetic relay switch, Type T2

#### DESCRIPTION

2. The relay switch (fig. 1) is a single-pole, double break switch, operated by an electromagnet. The closing of a control switch energizes the coil and attracts the core until it abuts the magnet end plate (fig. 2). The core is carried on a central spindle which moves downwards against spring tension. Also mounted on the spindle is a copper contact plate; when the relay is energized, this plate bridges the main terminals and completes the circuit to the load.

#### INSTALLATION

3. The control switch may be mounted in any convenient position, enabling the relay to be placed in or near the main run of heavy cables. The relay should be mounted on a vertical panel, with the cable entry uppermost, since in this position the action of the return spring is assisted by gravity when the

(A.L.1, Dec. 57)

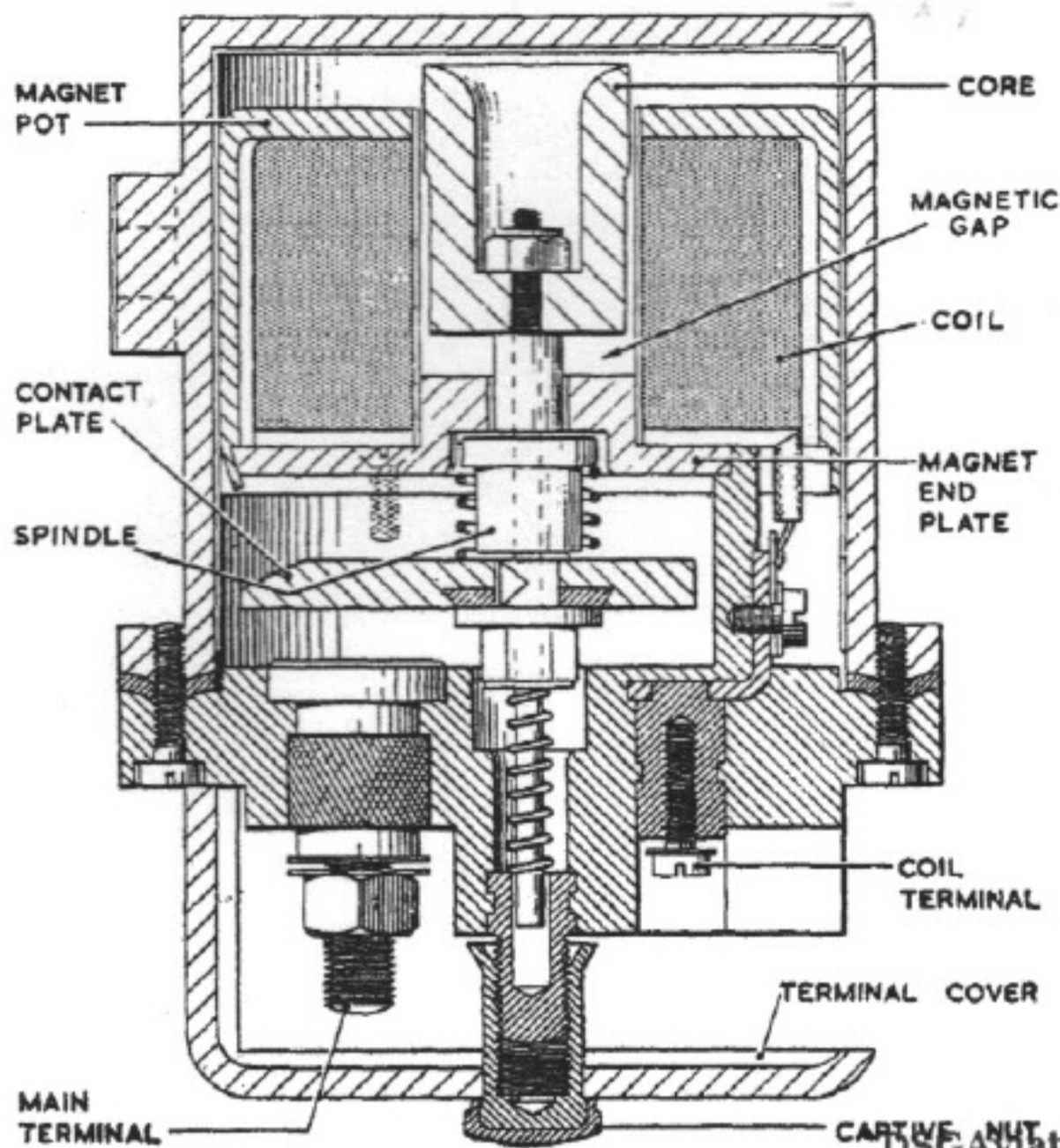

Fig. 2. Sectional view of switch

DSGAVIATION  
www.dsgaviation.co.uk  
mail@dsgaviation.co.uk

relay is de-energized. The terminal arrangement is shown in fig. 3.

#### SERVICING

4. The relay normally requires very little attention. The switch contacts and contact plate should be kept clean, and the operation of the unit should be checked.

#### Testing

##### Closing voltage

5. With the relay mounted on a vertical panel, terminals uppermost, the coil voltage should be gradually increased until the relay closes and the closing voltage noted. The relay must close with a snap, and under no circumstances should the armature move slowly; the closing voltage must lie between 8 and 15 volts.

##### Drop-out voltage

6. With the relay mounted on a vertical panel, terminals uppermost, the coil voltage is to be gradually decreased until the relay opens; the opening voltage must not exceed 5 volts.

#### Contact resistance

7. With the coil energized from a supply of 16 volts, and with a current of 100 amp. flowing in the main circuit, the voltage drop across the main terminals must not exceed 60 millivolts.

#### Insulation resistance

8. The insulation resistance is to be measured between the following points with a 250-volt insulation resistance tester, Type C (Stores Ref. 5G/152), and should not be less than 20 megohms.

- (1) Between one coil terminal and the case.
- (2) Between one coil terminal and both main terminals.
- (3) Between the main terminals.
- (4) Between one main terminal and the case with the relay closed.
- (5) Between one main terminal and one coil terminal with the relay closed.

9. Before assembly of the coil and magnet pot on the relay, the magnetic air gap should be checked with a feeler gauge; the settings are 0.162 in. to 0.146 in. with the switch contacts open, and 0.023 in. to 0.010 in. with the switch contacts closed.

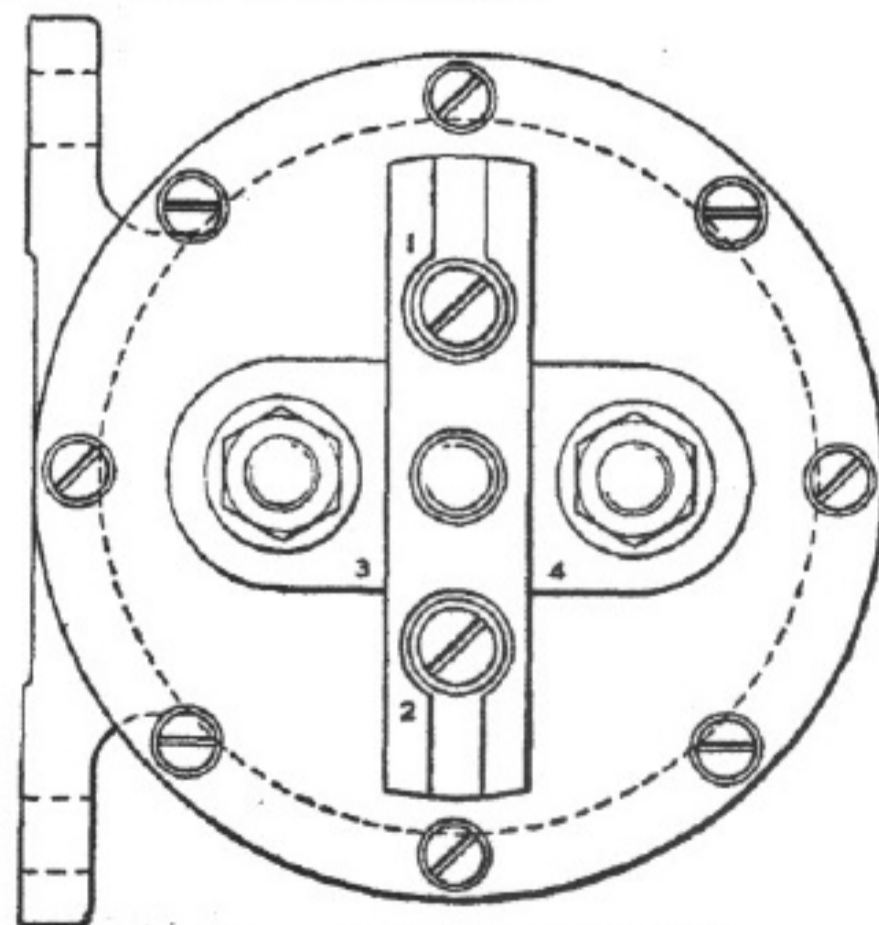

Fig. 3. Terminal arrangement

RESTRICTED

This file was downloaded  
from the RTFM Library:

Link: [www.scottbouch.com/rtfm](http://www.scottbouch.com/rtfm)

Please see site for usage terms,  
and more aircraft documents.

