

## Chapter 17

# MAGNETIC RELAY SWITCH, TYPE M1092

### LIST OF CONTENTS

Introduction ... ..	Para. 1	Servicing ... ..	Para. 6
Description ... ..	2		

### LIST OF ILLUSTRATIONS

Magnetic relay switch, Type M1092 ... ..	Fig. 1	Method of hermetically sealing the relay ...	Fig. 3
Relay removed from its casing ... ..	2		

### LEADING PARTICULARS

<b>Magnetic relay switch, Type M1092</b>	Inter-Service Ref. Z530003
Voltage ... ..	24 d.c.
Coil resistance at 15.6 deg. C. ... ..	670 ohms $\pm$ 5 per cent
Contact rating ... ..	1 amp. at 60V d.c. 0.1 amp. at 300V d.c. or a.c.
Overall dimensions—	
Height ... ..	1.75 in.
Width ... ..	1 in.
Length (over fixing studs) ... ..	2.5 in.
Weight ... ..	5 oz.
Minimum circuit current ... ..	21.4 mA

#### Introduction

1. The magnetic relay switch, Type M1092 (fig. 1), is a sealed, miniature type relay with

normal duty contacts; the contact arrangement is four change-over (break before make).

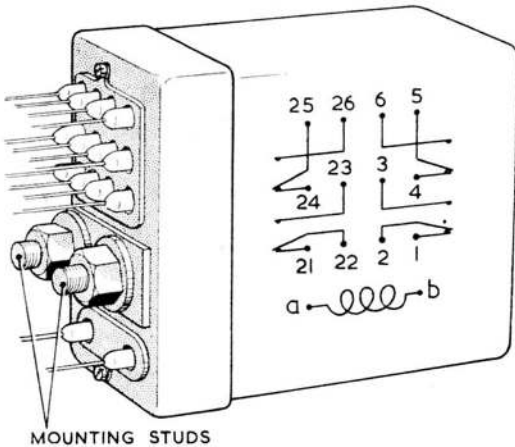

Fig. 1. Magnetic relay switch, Type M1092

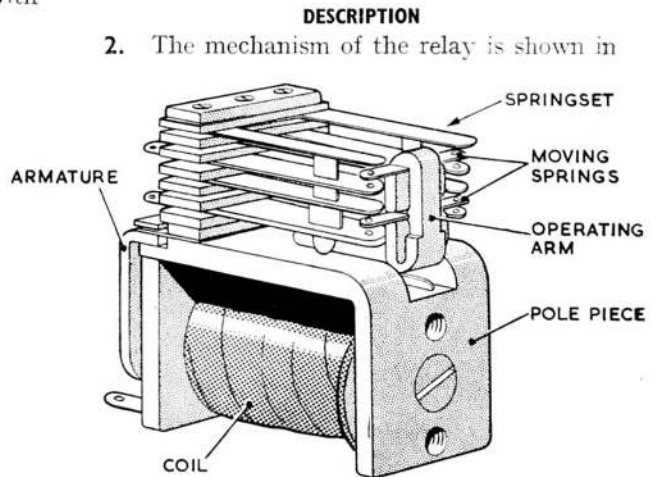

Fig. 2. Relay removed from its casing

(A.L.93, Feb. 57)

fig. 2. It incorporates an L-shaped pole piece, reduced in thickness at the armature end to form a step into which the armature fits and pivots on a flat spring attached to the pole piece. An extension on the armature passes along a slot in the long side of the pole piece, and an operating arm, riveted to the armature extension, operates the moving springs of the relay.

3. The springset is built up of flat springs with platinum contacts, and the complete assembly is fixed to the armature end of the pole piece. The coil is single wound, and, when energized, attracts the armature to operate the contacts.

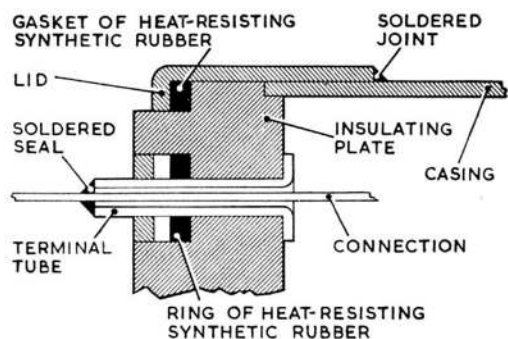

Fig. 3. Method of hermetically sealing the relay

4. The method of hermetically sealing the relay in its casing is illustrated in fig. 3. The connections from the contact springs and coil tags are brought out through the terminal tubes, and the ends of the tubes are sealed with solder. The lid is placed over the casing and pressure is applied to its top to exclude all air from between the synthetic rubber gasket on top of the insulating plate and the inside of the lid. Whilst under this pressure, the lid is soldered to the casing.

5. The relay is mounted by means of the two 4 B.A. studs protruding from a mounting plate secured to the lid of the relay.

#### SERVICING

6. Since this is a sealed item, no servicing is possible apart from a general inspection for freedom from damage and security of connections. The minimum circuit current of 21.4 mA quoted under Leading Particulars is that current which must normally be available for operation to ensure an adequate factor of safety; the switch should operate when a current of 20 mA is applied to terminals a and b.

This file was downloaded  
from the RTFM Library.

Link: [www.scottbouch.com/rtfm](http://www.scottbouch.com/rtfm)

Please see site for usage terms,  
and more aircraft documents.

