

Chapter 18

MAGNETIC RELAY SWITCH, TYPE M1101

LIST OF CONTENTS

	Para.		Para.
Introduction	1	Mounting	5
Description and operation	2		

LIST OF ILLUSTRATIONS

	Fig.		Fig.
Magnetic relay switch, Type M 1101	1	Diagram of contacts and coil connections and references	2

LEADING PARTICULARS

Magnetic relay switch, Type M1101	Stores Ref. 5CW/4616
Voltage	24 d.c.
Operating current	26 mA
Coil resistance	670 ohms. \pm 5 per cent
Dimensions	
Height	1.6 in.
Width	0.85 in.
Length	2.2 in.
Weight	3 oz.
Operating temperature range	-40 to + 85 deg. C.

Introduction

1. The magnetic relay switch, Type M1101 is an unsealed, miniature, heavy-duty type with 2 break and 2 make contacts.

DESCRIPTION AND OPERATION

2. The construction of the magnetic relay switch is illustrated in fig. 1. The pole-piece is L-shaped and reduced in thickness at the armature end to form a step into which the end of the armature fits. The armature is connected to the pole-piece by two leaf springs, and these enable the armature to move when the coil is energized. An extension on the armature passes along a slot in the long side of the pole-piece, and an operating arm, riveted to the armature extension, operates the moving springs of the relay.

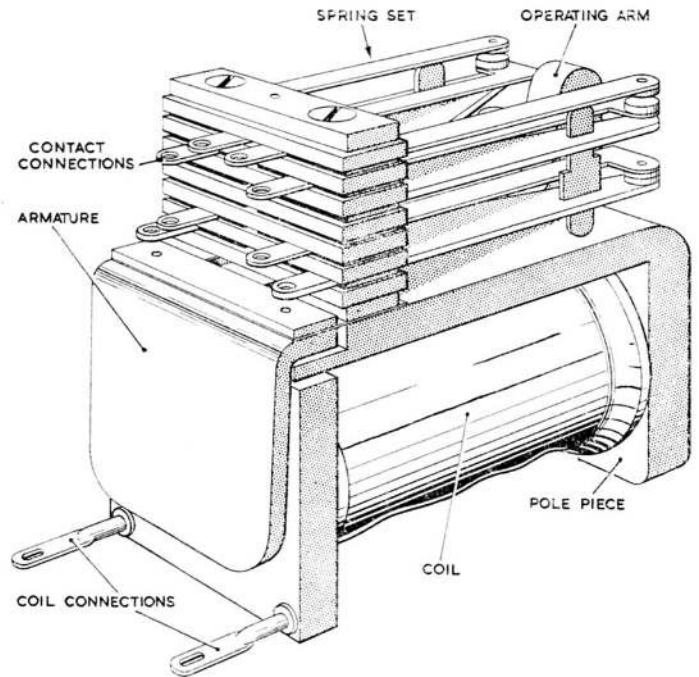

Fig. 1. Magnetic relay switch, Type M1101

3. The spring set is built up of insulating strips and flat springs with sintered-silver-nickel contacts, and the complete assembly is secured to the armature end of the pole-piece.

4. A single-wound coil is located between the armature and the short end of the pole-piece. When the coil is not energized, the movable contacts "make" with the bottom fixed contacts, and the upper contacts are opened. When the coil is energized, the armature moves and the movable contacts "make" with the upper fixed contacts while the bottom contacts open. A diagram of the contacts and coil connections and references is illustrated in fig. 2.

Mounting

5. Two 6 B.A. tapped holes are provided in the short end of the pole-piece for fixing the relay in any suitable position.

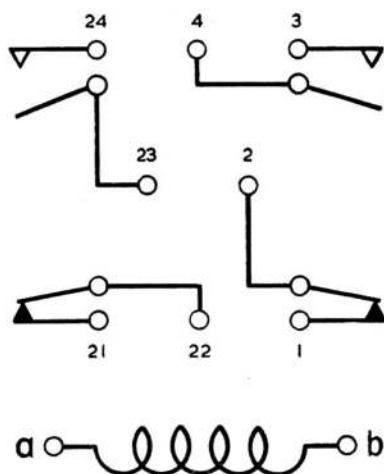

Fig. 2. Diagram of contacts and coil connections and references

This file was downloaded
from the RTFM Library.

Link: www.scottbouch.com/rtfm

Please see site for usage terms,
and more aircraft documents.



**TELEBRIEF
CONNECTIONS**

E