

Chapter 19

BALANCER RELAY, TYPE MAA

LIST OF CONTENTS

	Para.		Para.
<i>Introduction</i>	1	<i>Installation</i>	7
<i>Description</i>	2	<i>Servicing</i>	8
<i>Operation</i>	3		

LIST OF ILLUSTRATIONS

	Fig.		Fig.
<i>Balancer relay, Type MAA</i>	1	<i>Circuit diagram</i>	3
<i>Relay with covers removed</i>	2		

LEADING PARTICULARS

Balancer relay, Type MAA	Stores Ref. 6A/3131
<i>Voltage</i>24
<i>Current</i>	5 amp.
<i>Weight</i>	38.5 oz.
<i>Dimensions</i>	7 in. × 4 in. × 3.6 in.

Introduction

1. The balancer relay, Type MAA, is used in certain Smiths-Waymouth fuel gauge installations to preserve the balance between the contents of a number of tanks as their fuel content changes. It is operated by the differential current between the indicator circuits from two amplifiers, and therefore can be incorporated only in an installation which has two or more amplifiers, each serving a tank or group of tanks. The relay thence controls the circuit to the relevant fuel tank pump to correct the state of unbalance.

DESCRIPTION

2. The balancer relay (*fig. 1 and 2*) incorporates a moving coil assembly and two double-pole, normally-open slave re-

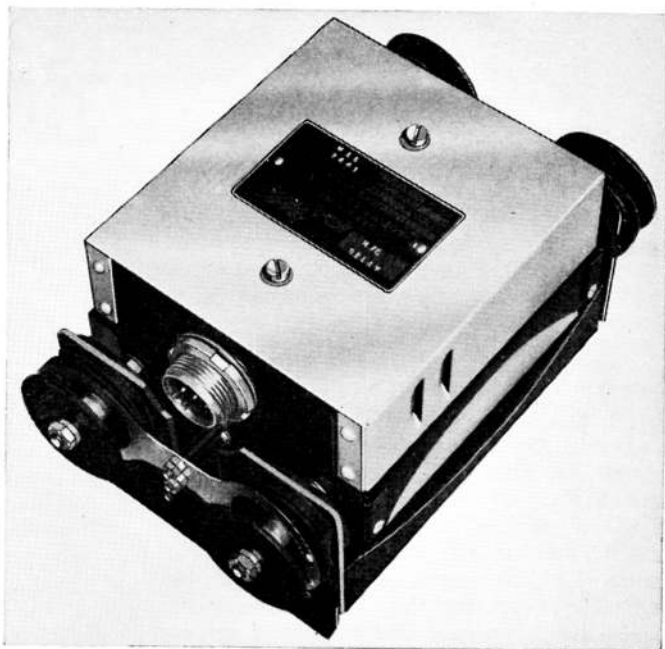

Fig. 1. Balancer relay, Type MAA

(A.L.9, Mar. 55)

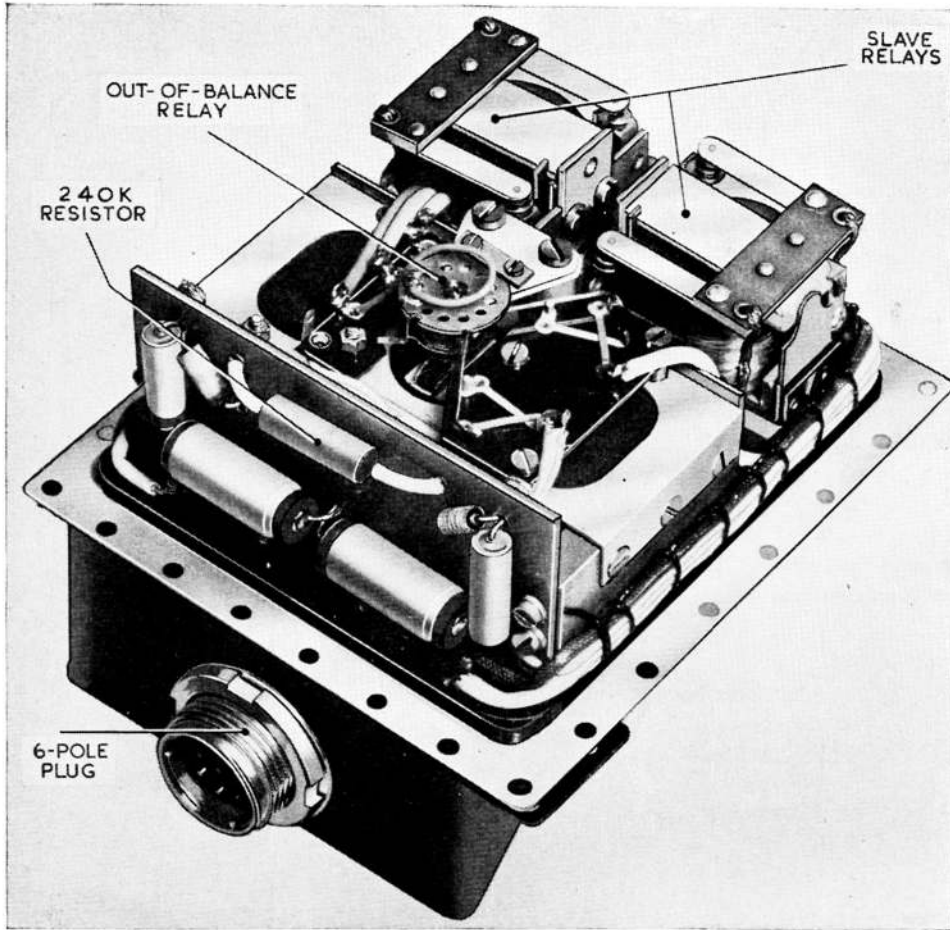

Fig. 2. Relay with covers removed

lays, with associated resistors and capacitors. The components are mounted on a light alloy base plate, and the complete unit is hermetically sealed in a standard fuel gauge amplifier case with an anti-vibration mounting. This mounting is similar to that used for the amplifier, but has an extra damper plate because of the increased weight.

Operation

3. A circuit diagram of the balancer relay is given in fig. 3. If the contents of the tanks served by indicator A are in the correct ratio to those of the tanks served by indicator B, the system will be in a state of balance, and no current will flow in the moving coil relay. If, however, the current through one indicator is greater than that through the other, due to unequal fuel content, a current will flow through the moving coil in one direction or the other, depending on which

tanks hold the greater amount of fuel. When this current reaches a value of between 0.1 mA and 0.15 mA, it will cause the moving coil to operate, and swing the positive contact from the centre position to close on one of the side contacts.

4. Closing of these contacts energizes one or other of the slave relays. In each of these relays, one pair of contacts, shown as No. 1, has a gap of 0.040 in., while the other pair, No. 2, has a gap of 0.025 in. When the coil is energized, No. 2 contacts close first, and complete a hold-in circuit incorporating R2. This causes an increase in the voltage drop in R1, and results in an additional current of about 0.1 mA, known as the hold-in current, through the moving coil.

5. No. 1 contacts in the relay then close which connects the positive supply to the relevant pump control circuit, to correct

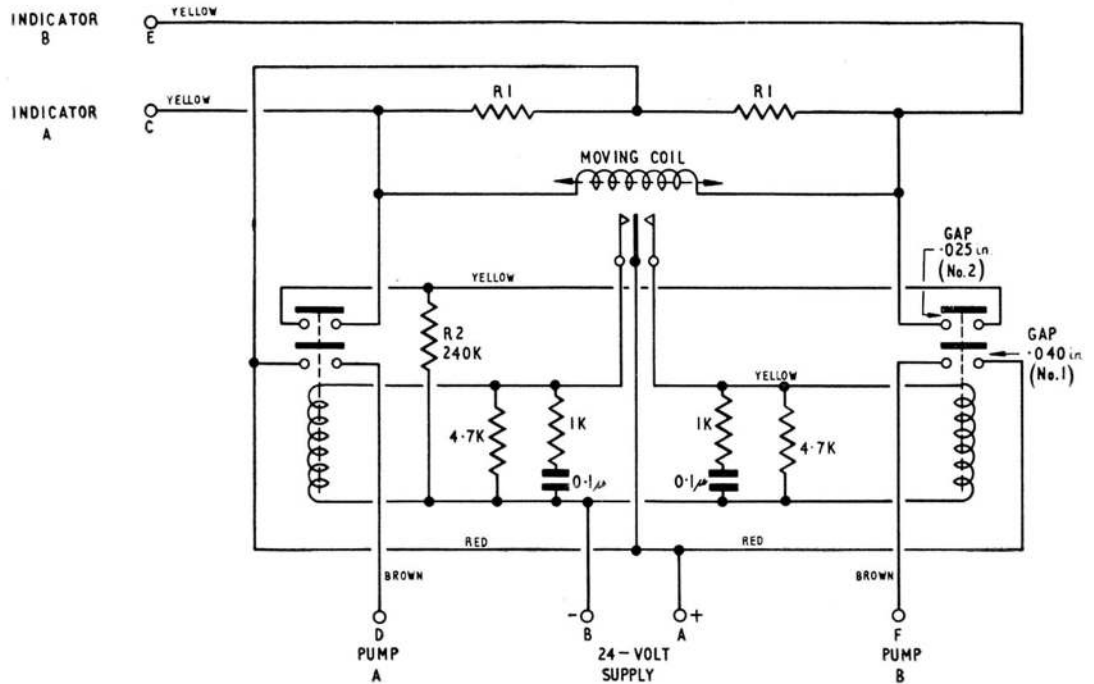

Fig. 3. Circuit diagram

the relative contents of the tanks. The hold-in current ensures that the contacts of the moving coil relay are kept closed until the indicator currents through the coil are once more in balance, due to the fuel contents of the tanks being again in the correct ratio. If the hold-in current were not added to the current through the moving coil, the relay would cut out again as soon as the fuel pump had caused the out-of-balance factor in the coil to drop a little below the cut-in figure. This would still leave a relatively large out-of-balance current in the moving coil, and as soon as this had increased a fraction, the process would be repeated, causing the system to hunt. With the hold-in current method, however, only a very small out-of-balance factor remains when the relay is de-energized and the additional current in the moving coil is cut out.

6. The resistors and capacitors which are connected across the relay coils are incorporated to prevent arcing at the moving coil relay contacts.

INSTALLATION

7. Electrical connection to the relay is made at a 6-pole Mk. 4 miniature plug on the end face. The relay should be mounted vertically, with the plug at the bottom. Details of a particular installation will be found in the relevant Aircraft Handbook.

SERVICING

8. Since the complete unit is hermetically sealed, no servicing of the balancer relay is possible. A functional test may be given to ensure that the relay operates with an out-of-balance current of between 0.1 mA and 0.15 mA.

This file was downloaded
from the RTFM Library.

Link: www.scottbouch.com/rtfm

Please see site for usage terms,
and more aircraft documents.

