

Chapter 2

MAGNETIC RELAY SWITCH, TYPE K

LIST OF CONTENTS

	Para.		Para.
Introduction...	1	Testing	
Description	2	Closing voltage ...	5
Installation	3	Contact resistance ...	6
Servicing ...	4	Insulation resistance ...	7

LIST OF ILLUSTRATIONS

	Fig.		Fig.
Magnetic relay switch, Type K3 ...	1	Sectional view of switch ...	2

LEADING PARTICULARS

Type K3 ...	Stores Ref. 5CW/2472
Operating voltage ...	24
Continuous rating ...	100 amp.
Coil resistance ...	90.8 ohms
Dimensions ...	3 in. × 2.8 in. × 4 in.
Weight ...	1 lb. 13 oz.
Type K ...	Stores Ref. 5CW/2471
Operating voltage ...	12
Coil resistance ...	21.9 ohms
Other details as Type K3	

Introduction

1. The magnetic relay switches, Type K, are suitable for the remote control of circuits where the current does not exceed 100 amp.

DESCRIPTION

2. The relay (*fig. 1*) comprises a single-pole, double break switch, operated by an electromagnet. The closing of a control switch energizes a moving copper contact plate to bridge the two main terminals and energize the load to which the relay is connected. A sectional view is given in *fig. 2*.

INSTALLATION

3. The control switch can be placed in any convenient position, enabling the relay to be placed in or near the main run of the heavy cables. Due to a heavy drain of current in the main circuit when the relay contacts close, the voltage across the coil will drop. To minimize this drop in voltage, the coil circuit should be connected to the supply as near to the battery terminals as possible. The relay should be so mounted that the cable entry

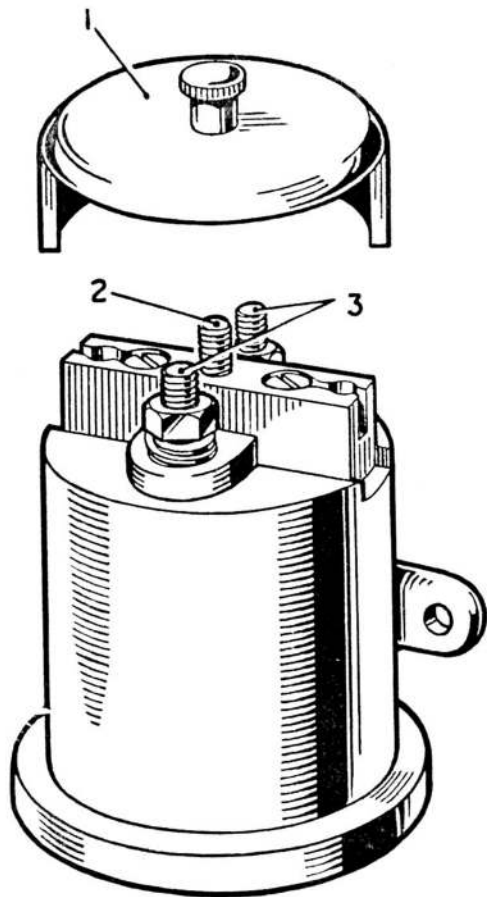

- 1 TERMINAL COVER
- 2 COVER SCREW
- 3 MAIN TERMINALS

Fig. 1. Magnetic relay switch, Type K3

comes uppermost, as, when in this position, the action of the return spring is assisted by gravity when the relay is de-energized.

SERVICING

4. The relays normally require very little attention. The switch contacts and contact plate should be kept clean, and the operation of the unit should be checked.

Testing

Closing voltage

5. With the relay standing on its base, terminals uppermost, the coil voltage should be gradually increased until the relay closes, and the closing voltage noted. The relay must close with a snap, and under no circumstances

should the armature move slowly or the closing voltage exceed 16 volts (8 volts for the 12-volt unit).

Contact resistance

6. With the coil energized from a supply of 16 volts (8 volts for the 12-volt unit), and with a current of 100 amp. flowing in the main circuit, the voltage drop across the main terminals must not exceed 50 millivolts.

Insulation resistance

7. The insulation resistance is to be measured between the following points with a standard insulation resistance tester, and should not be less than 20 megohms.

- (1) Between one coil terminal and the case.
- (2) Between one coil terminal and both main terminals.
- (3) Between the main terminals.
- (4) Between one main terminal and the case, with the relay closed.
- (5) Between one main terminal and one coil terminal, with the relay closed.

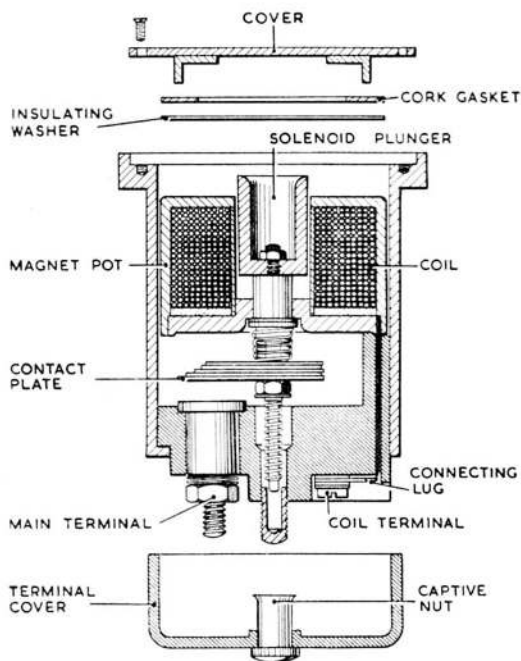

Fig. 2. Sectional view of switch

RESTRICTED

This file was downloaded
from the RTFM Library.

Link: www.scottbouch.com/rtfm

Please see site for usage terms,
and more aircraft documents.

