

Chapter 28

PROPELLER FEATHERING SWITCH, TYPE XJD/4

LIST OF CONTENTS

	Para.		Para.
Introduction...	1	Dismantling...	9
Description ...	3	Assembly ...	11
Servicing		Tests ...	13
General ...	7		

LIST OF ILLUSTRATIONS

	Fig.		Fig.
Propeller feathering switch, Type XJD/4 ...	1	Terminal block moulding ...	4
Exploded view of switch, Type XJD/4 ...	2	Circuit diagram ...	5
Sectional view of switch, Type XJD/4 ...	3		

LEADING PARTICULARS

Propeller feathering switch, Type XJD/4 ...	Stores Ref. 5CW/4854
Overall length ...	4.6 in.
Dimensions of mounting flange ...	2 x 2 in.
Maximum voltage ...	29 V d.c.
Minimum hold-in voltage ...	9 V d.c.
Continuous current rating ...	5 amp.
Solenoid coil resistance ...	60 ohms \pm 10 per cent

Introduction

1. The Type XJD/4 switch (*fig. 1*) normally controls the propeller feathering circuit. It is manually operated but incorporates a solenoid which holds the switch in the on position until the propeller is fully feathered, at which point the solenoid circuit is automatically switched off.

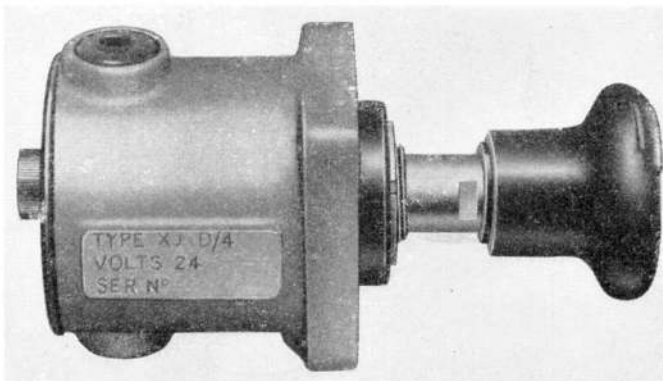

Fig. 1. Propeller feathering switch, Type XJD/4

2. A warning lamp in the plunger knob is in circuit with the fire extinguisher system, and lights up automatically when the operation of any one of the flame switches in the engine bay concerned brings the fire extinguisher circuit into action. Low oil pressure and loss of coolant are also shown on this warning lamp, but these faults will result in a flickering light instead of the steady light which indicates the operation of a flame switch.

DESCRIPTION

3. The switch (*fig. 1*) consists of a light metal body housing a plunger, which, when depressed, makes contact with leaf spring contacts attached to the terminal studs. Two circuits are completed in succession through these contacts; first, the circuit operating the feathering of the propeller, and secondly, the solenoid circuit which holds the plunger in the depressed position until

(A.L.57, Feb. 56)

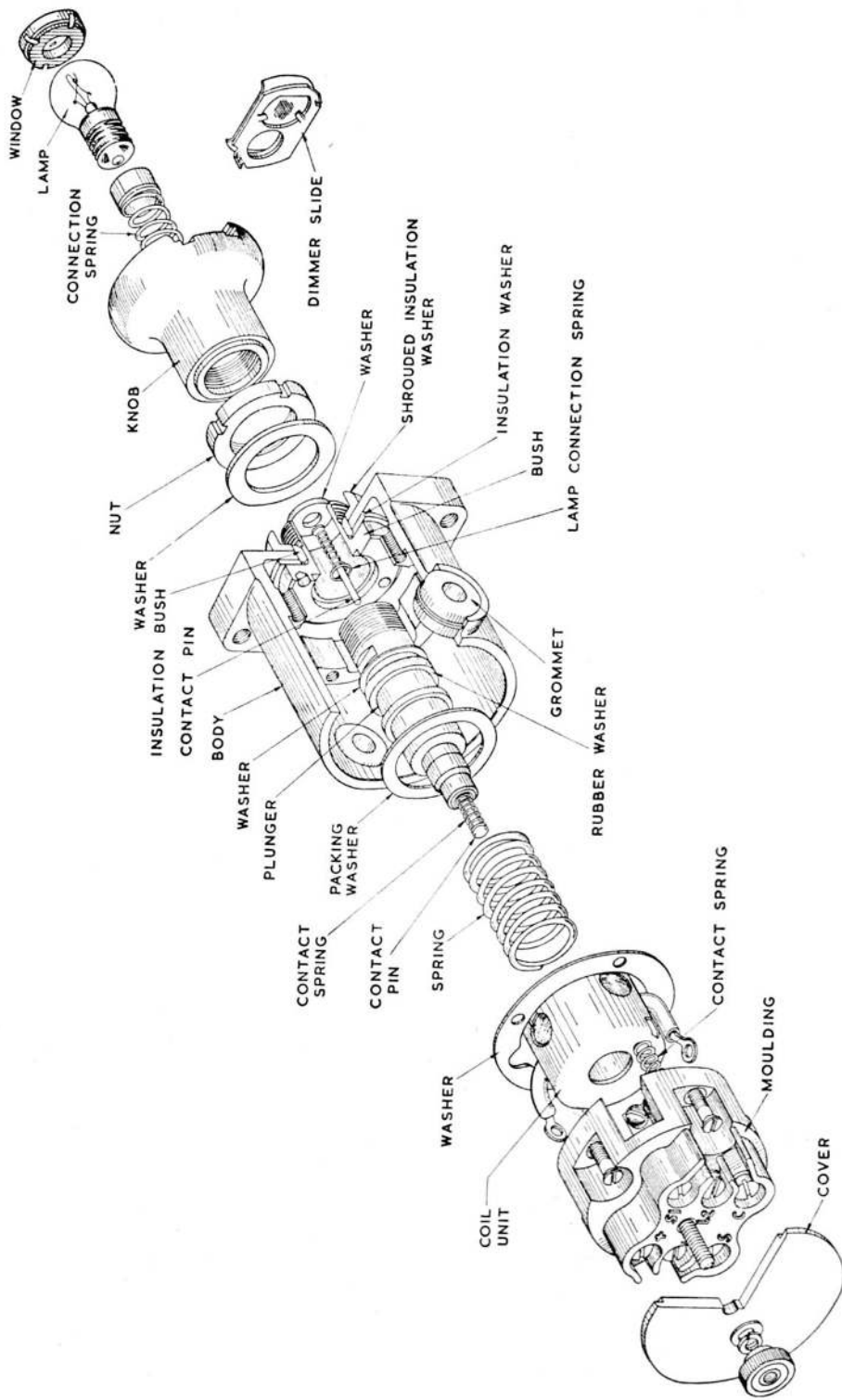

Fig. 2. Exploded view of switch, Type XJD/4

RESTRICTED

the propeller is fully feathered. As soon as the propeller reaches the fully feathered position, the circuit controlling its pitch variation is broken, and the solenoid is de-energized.

4. The plunger knob (*fig. 2 and 3*) screws on to the plunger, and houses the warning lamp, which slips into the lampholder and makes contact with a rod running through the centre of the plunger to the contact spring. The lamp is covered by an amber dimmer screen, and both are held in position by a blanking screen.

5. When the plunger is depressed, the contact sleeve makes contact with three leaf spring contacts, two on the inboard end of the terminals marked S and S1, to which the ends of the solenoid coil are attached, and one on the terminal for the positive supply. A circuit diagram is given in *fig. 5*, and a view of the terminal block moulding, in *fig. 4*.

6. The terminal block is held in place in the metal switch body by four screws. A threaded stud, moulded into the terminal block, locates the terminal cover, which is locked on by the nut and washer. The cable entries in the switch body are fitted with rubber grommets to make the connection weatherproof.

SERVICING

General

7. The filament lamp should be examined regularly and renewed when necessary. To remove the lamp from the knob, the blanking screen should be put so that the open section is over the amber screen. Press in the amber screen with the end of a pencil, or other suitable implement. This releases the spring pressure on the blanking screen, which will then slide out of its grooves in the plunger knob. Care should be taken that the amber screen and the filament lamp do not spring out as the blanking screen is removed.

8. To replace the lamp, put it into the lamp-holder, holding it in position with the amber screen (rubber washer side next to the lamp), then slide the blanking screen into the grooves of the knob and over the top of the amber screen.

Dismantling

9. To dismantle the switch for internal inspection, unscrew the terminal cover nut and washer, and take off the terminal cover. Unscrew the four screws securing the terminal block in the switch body; holding the cover-locating stud in one hand, press the plunger knob with the other, and the terminal block and solenoid coil will come away together.

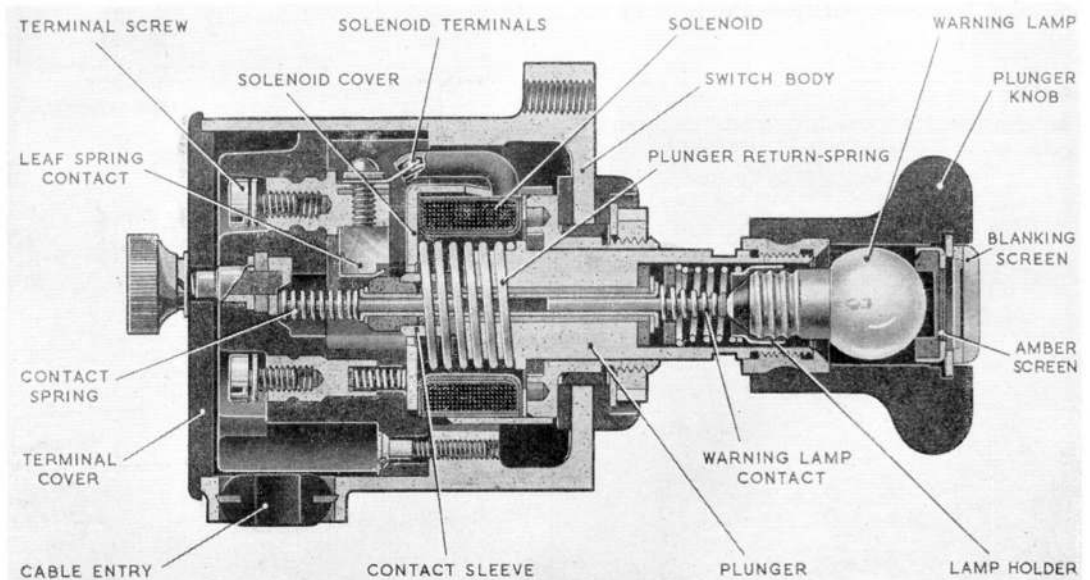

Fig. 3. Sectional view of switch, Type XJD/4

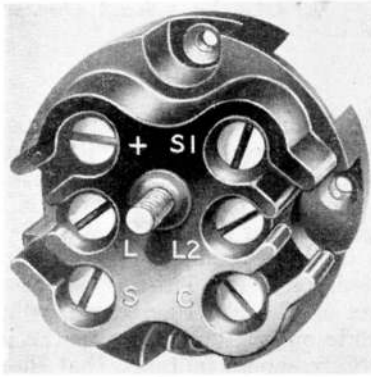

Fig. 4. Terminal block moulding

Care should be taken not to lose the plunger return spring, which is housed loosely inside the solenoid coil.

10. Inspect the leaf spring contacts, and the plunger sleeve contacts for cleanliness and pitting. If slightly pitted, they may be cleaned using grade 000 glasspaper. Inspect the spring contacts for the warning lamp circuit. Test the plunger movement to ensure it moves freely in its guide. Lubricate the contacts and the plunger very lightly with grease XG-275 (Stores Ref. 34B/100512). The lubricant should be applied to the plunger shaft outside the switch body and worked in. If this is not sufficient, remove the filament lamp and screens, hold the plunger shaft firmly and unscrew the knob; the shaft can then be drawn out from the back of the switch body.

Assembly

11. Ensure that the interior of the switch body is clean and that the cable entry

grommets are in good condition. If the switch has been completely stripped, consult fig. 2 for the correct order of assembly. Ensure that no acid or grease contaminates the rubber washers and grommets.

12. The terminal moulding and solenoid should be assembled together, taking care that the contact spring is correctly located in its hole and is making contact with the underside of the solenoid cup. The slot in the cup must engage with the key in the moulding. Connect the solenoid leads to the underside of the terminals marked S and C, as indicated in fig. 2.

Tests

13. Using a 250-volt insulation tester and with the switch closed by hand, the insulation resistance, between any terminal and earth, must be not less than 2 megohms. With the switch open, the insulation resistance between terminals (except between S and C and between L1 and L2) must be not less than 2 megohms. The continuity resistance between terminals S and C should be within the limits of 60 ohms \pm 10 per cent.

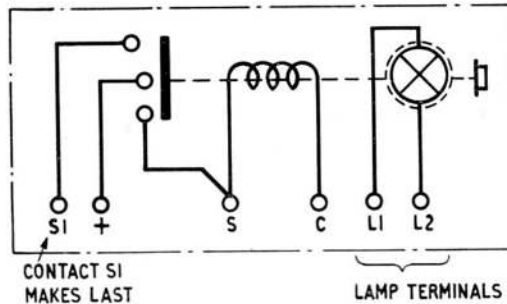

Fig. 5. Circuit diagram

This file was downloaded
from the RTFM Library.

Link: www.scottbouch.com/rtfm

Please see site for usage terms,
and more aircraft documents.

