

Chapter 29

THERMOSTAT UNIT, TYPE A

LIST OF CONTENTS

	Para.		Para.
Introduction	1	Operation	9
Description	2	Servicing	10
Installation	8		

LIST OF ILLUSTRATIONS

	Fig.		Fig.
Exploded view of thermostat unit...	1	Details of thermostatic switch	2

LEADING PARTICULARS

Thermostat unit, Type A	Stores Ref. 5CZ/3601
Operating voltage	24
Current consumption	1 amp.

Introduction

1. The thermostat unit, Type A, is designed primarily to control the circuit to an electrically-heated muff employed with the F24 camera. The unit breaks the heater circuit automatically when the atmospheric temperature is such that muff heating is not required.

DESCRIPTION

2. The unit comprises a thermostatic switch, Type KV, housed in a metal casing. A terminal block of moulded bakelite is secured to the lid of the casing by two threaded pillars, nuts, and washers; the latter are accessible only after removing the lid which is secured to the main body of the casing by four round-headed screws. A moulded bakelite cover, with a rubber gasket to exclude dirt and moisture, is fitted to the terminal block by two slotted captive nuts. Any abrasion of the leads at their point of entry into the terminal block is prevented by the inclusion of a pair of rubber cable grommets, which locate in slots in the moulding.

3. Although three terminals are located in the terminal block, only the outer two are used. Insulating shrouds, moulded integral with the terminal block, project between the terminal screws to prevent shorting. The terminal pillars, which the terminal screws

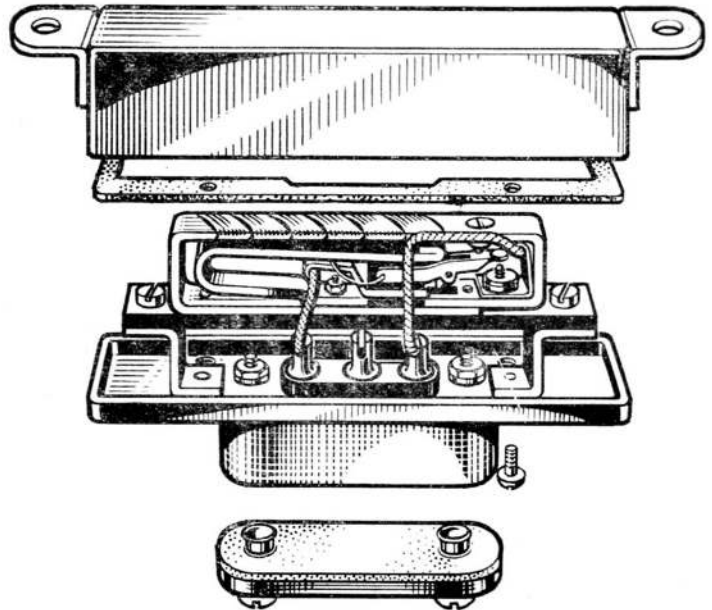

Fig. 1. Exploded view of thermostat unit

engage, pass through the lid of the casing and are slotted so that the switch leads may be soldered to them.

4. Two small double-angle brackets are riveted to the underside of the lid of the casing and to these brackets is screwed a strip of insulating material upon which the thermostatic switch is mounted.

5. The switch itself is built up within a rectangular former of strip metal and is actuated by a U-shaped component of bi-metallic construction. The bi-metal consists of two dissimilar metals, with different rates of expansion, pressed together so that at certain temperatures the arms of the bi-metal contract inwards or expand outwards, tripping a spring-loaded cam that operates a contact arm. The latter then either makes or breaks the muff heater circuit as described in para. 9.

6. One end of the U-shaped bi-metal strip is secured to the metal former by a cheese-headed screw end nut whilst the other end is slotted to accept a pivot rod that is soldered in position. The pivot rod carries a spring-loaded trip cam, the spring being so arranged as to force the cam forward against a further rod fitted in the moving contact arm. The shape of the cam ensures that the moving contact arm is in one of two positions, according to the effect of the atmospheric temperature on the bi-metal. Firstly, it may rest against the contact arm stop, the switch then being in the open position or, alternatively, it may rest on the fixed contact, in which case the switch is closed. In the latter case the muff heater circuit is completed by way of the input terminal in the terminal block, a pressed tag on the contact arm mounting block, the moving contact arm, and thence through the contact points, and a second tag attached to the fixed contact to the output terminal.

7. It is emphasized that when handling this switch, care must be taken to avoid putting any thrust on the bi-metal which may tend to displace it sideways. The very small force required to actuate the switch should be applied vertically at the point X shown in fig. 2, i.e., directly above the bi-metal fixing screw.

INSTALLATION

8. The thermostat unit is provided with two fixing lugs. Before securing the muff heater circuit leads to the terminals of the unit, the ends of the rubber cable grommets may have to be pierced to allow the leads to pass through. If this is necessary, the holes should be made as small as possible to prevent moisture entering the terminal block. Cable connections to the terminals should be made securely, and the terminal block cover afterwards screwed firmly down, so that the rubber gasket on the cover forms a complete seal against the ingress of dirt and moisture.

OPERATION

9. The operation of the thermostatic switch in the unit is dependent upon the effect of atmospheric temperature upon the bi-metal strip. The bi-metal is so designed and constructed that the arms of the U thrust outwards, actuating and closing the switch with a falling temperature at not less than 3 deg. Centigrade. Conversely, the arms of the U tend to draw together with a rising temperature until at not more than 16 deg. Centigrade the switch should open.

SERVICING

10. Periodically, the terminal block cover should be removed and the terminals examined. The cable connections should be secure and in a satisfactory condition. If the thermostat unit is unsatisfactory in operation, a new one should be fitted.

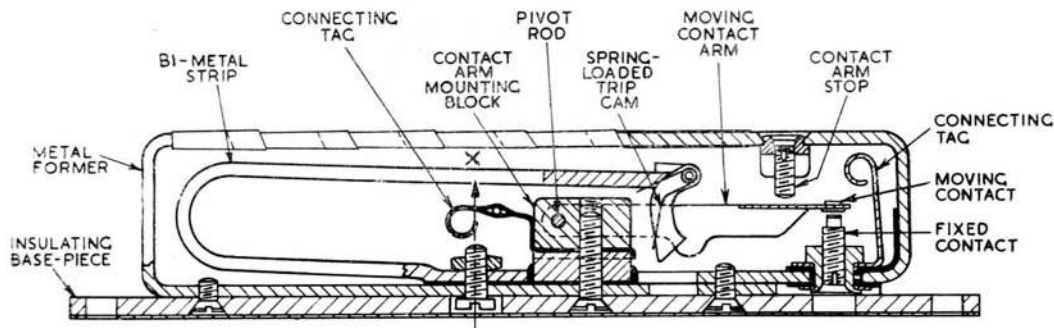

Fig. 2. Details of thermostatic switch

RESTRICTED

This file was downloaded
from the RTFM Library.

Link: www.scottbouch.com/rtfm

Please see site for usage terms,
and more aircraft documents.

