

Chapter 34

MAGNETIC RELAY SWITCH, TYPE M1093

LIST OF CONTENTS

	Para.		Para.
Introduction...	1	Servicing ...	6
Description ...	2		

LIST OF ILLUSTRATIONS

	Fig.		Fig.
Magnetic relay switch, Type M1093 ...	1	Method of hermetically sealing the relay ...	3
Relay removed from its casing ...	2		

LEADING PARTICULARS

Magnetic relay switch, Type M1093	Inter-Service Ref. Z530012
Voltage ...	24 d.c.
Coil resistance at 15.6 deg. C. ...	670 ohms \pm 5 per cent
Contact rating ...	1 amp. at 60V d.c. 0.1 amp. at 300V d.c. or a.c.
Overall dimensions—	
Height ...	1.75 in.
Width ...	1 in.
Length (over fixing studs) ...	2.5 in.
Weight ...	5 oz.
Minimum circuit current ...	21.4 mA

Introduction

1. The magnetic relay switch, Type M1093 (*fig. 1*) is a sealed, miniature type relay with normal duty contacts; the contact arrangement is two change-over (break before make), and two change-over (make before break).

DESCRIPTION

2. The mechanism of the relay is shown in *fig. 2*. It incorporates an L-shaped pole piece, reduced in thickness at the armature end to form a step into which the armature fits and pivots on a flat spring attached to the pole piece. An extension on the armature passes along a slot in the long side of the pole piece, and an operating arm, riveted to the armature extension, operates the moving springs of the relay.

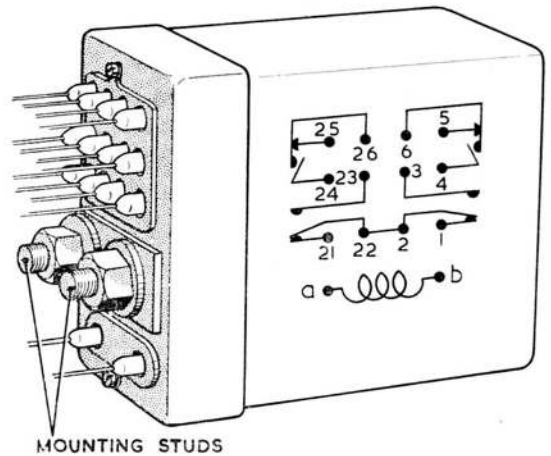

Fig. 1. Magnetic relay switch, Type M1093

(A.L.93, Feb. 57)

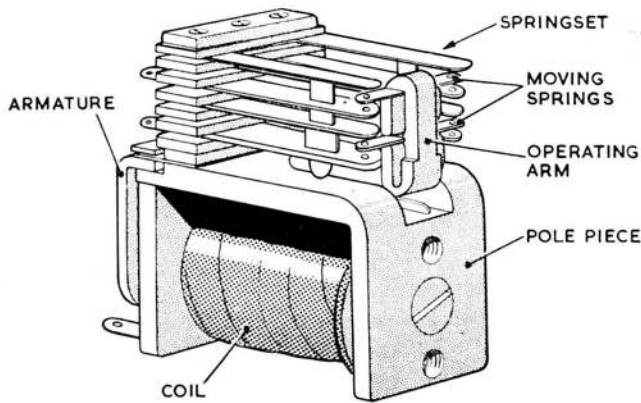

Fig. 2. Relay removed from its casing

3. The springset is built up of flat springs with platinum contacts, and the complete assembly is fixed to the armature end of the pole piece. The coil is single wound, and, when energized, attracts the armature to operate the contacts.

4. The method of hermetically sealing the relay in its casing is illustrated in fig. 3. The connections from the contact springs and coil tags are brought out through the terminal tubes, and the ends of the tubes are sealed with solder. The lid is placed over the casing and pressure is applied to its top to exclude all air from between the synthetic rubber gasket on top of the insulating plate and the inside of the lid. Whilst under this pressure the lid is soldered to the casing.

5. The relay is mounted by means of the two 4 B.A. studs protruding from a mounting plate secured to the lid of the relay.

SERVICING

6. Since this is a sealed item, no servicing is possible apart from a general inspection

for freedom from damage and security of connections. The minimum circuit current of 21.4 mA quoted under Leading Particulars is that current which must normally be available for operation to ensure an adequate factor of safety; the switch should operate when a current of 20 mA is applied to terminals a and b.

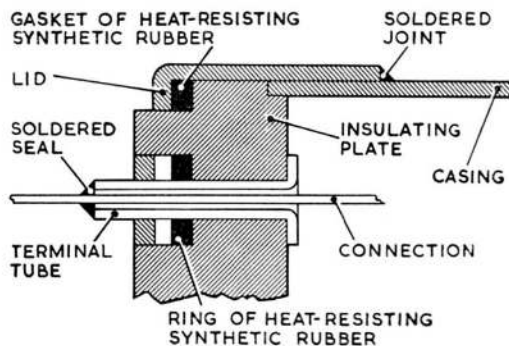

Fig. 3. Method of hermetically sealing the relay

This file was downloaded
from the RTFM Library.
Link: www.scottbouch.com/rtfm
Please see site for usage terms,
and more aircraft documents.

