

Chapter 36

RELAYS, B.T.H. TYPE LA (24-VOLT)

LIST OF CONTENTS

	Para.		Para.
Introduction	1	Setting and testing values	
Relay types	2	Coil resistance	5
Connections and polarity	3	Settings	6

LIST OF TABLES

	Table		Table
Relay types	1	Coil resistance	3
Connections and polarity	2	Relay settings	4

LIST OF ILLUSTRATIONS

		Fig.
Internal connections		1

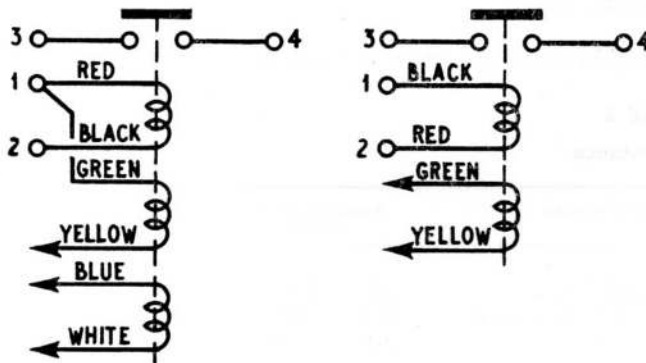

TYPE LAK-B1

TYPE LAD.10-B1

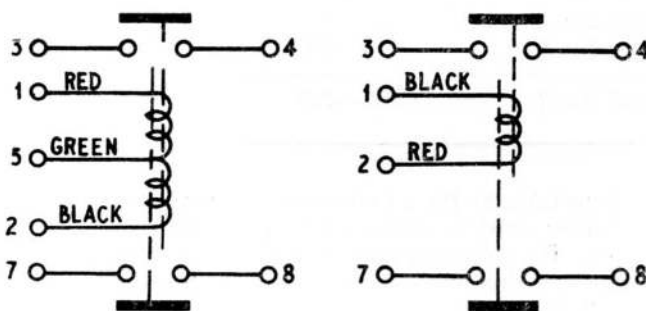

TYPE LAA.20-B3

TYPE LAA.20-B4

Fig. 1. Internal connections

Introduction

1. This chapter gives the relevant data and test limits of a number of 24-volt relays included in the B.T.H. Type LA range. The description, operation, and servicing of this range of relays is covered in A.P.4343, Vol. 1, Sect. 11, Chap. 15 to which reference should be made as required.

RELAY TYPES

2. The relays covered in this chapter are listed in Table 1. Their internal connections are shown in fig. 1.

TABLE 1
Relay Types

Relay Type	Stores Ref.	Number of coils	Number of case units
LAK. —B1	5CW/5618	3	1
LAD.10—B1	5CW/5619	2	1
LAA.20—B3	5CW/5620	2	2
LAA.20—B4	5CW/5621	1	2

(A.L.20, May 55)

Connections and polarity

3. To ensure that the polarities of the relays are correct, the coil connections must be made according to Table 2. Where a relay has additional coil leads, not connected to case unit terminals, these leads should be connected strictly in accordance with the circuit diagram of the control equipment incorporating the relay.

4. Table 2 also lists the corresponding armature polarities, the polarity of an armature referring to that end which has the small armature peg attached. In the table, case unit "A" is that fitted with terminals No. 1, 2, 3 and 4, and case unit "B" is that fitted with terminals No. 5, 6, 7 and 8.

TABLE 2
Connections and polarity

Relay Type	Coil connections				Armature polarity	
	Terminal No. 1	Terminal No. 2	Terminal No. 5	Free leads	Case unit "A"	Case unit "B"
LAK-B1	Red and Green	Black	—	Yellow, Blue and White	S	—
LAD.10-B1	Black	Red	—	Yellow and Green	N	—
LAA.20-B3	Red	Black	Green	—	N	S
LAA.20-B4	Black	Red	—	—	S	N

SETTING AND TESTING VALUES

Coil resistance

5. The resistances of the relay coils should lie within the ranges given in Table 3.

TABLE 3
Coil resistance

Relay Type	Resistance measured between	Resistance limits (ohms)
LAK-B1	Terminals No. 1 and No. 2	630—770
	Terminal No. 1 and Yellow lead	0.52—0.64
	Blue and White leads	0.147—0.180
LAD.10-B1	Terminals No. 1 and No. 2	0.20—0.24
	Yellow and Green leads	0.20—0.24
LAA.20-B3	Terminals No. 1 and No. 5	34—42
	Terminals No. 2 and No. 5	740—900
LAA.20-B4	Terminals No. 1 and No. 2	103—125

Settings

6. The pick-up and drop-off setting limits are given in Table 4. These settings should be checked by connecting a variable d.c. supply to the coil terminals specified. The relay contacts are referred to by the case unit terminals to which they are connected.

7. When checking the settings of the relay,

Type LAA.20-B3, a 1,000-ohm (± 2 per cent) resistor must be connected in series with the coil. The voltmeter must be connected across this combination so as to include the resistor volt drop.

Note . . .

Current settings are to be measured for relay, Type LAA.20-B4.

RESTRICTED

TABLE 4
Relay settings

Relay Type	Test connections		Pick-up limits		Drop-off limits
	Supply positive	Supply negative	Contacts 3-4	Contacts 7-8	
LAK-B1	Terminal No. 1	Yellow lead	175-200mV	—	30-40 mV
LAD.10-B1	Terminal No. 1	Terminal No. 2	115-125 mV	—	Over 10 mV
LAA.20-B3	Terminal No. 5 (and 1,000-ohm resistor)	Terminal No. 1	15-17 volts	35-36 volts	Under 2 volt
LAA.20-B4	Terminal No. 2	Terminal No. 1	0.39-0.44 amp.	0.65-0.71 amp.	Over 0.1 amp.

This file was downloaded
from the RTFM Library.

Link: www.scottbouch.com/rtfm

Please see site for usage terms,
and more aircraft documents.

