

Chapter 40

SWITCH, MAGNETIC, TYPE 2A, No. 1 (ROTAX F3105)

LIST OF CONTENTS

	Para.
Introduction... ..	1
Description	2

LIST OF ILLUSTRATIONS

	Fig.
Type 2A, No. 1 magnetic switch	1
Diagram of connections	2

LEADING PARTICULARS

Switch, magnetic, Type 2A, No. 1	Stores Ref.	5CW/4601
Voltage		28V, d.c.
Minimum pull-in voltage (20 deg. C)... ..		16V, d.c.
Drop out voltage		5 to 2V, d.c.
Current rating		5 amp.
Operating coil resistance		179 ohm
Overall dimension of base		3.128 by 3.0 in.
Height		3.468 in.
Weight		15.25 oz.

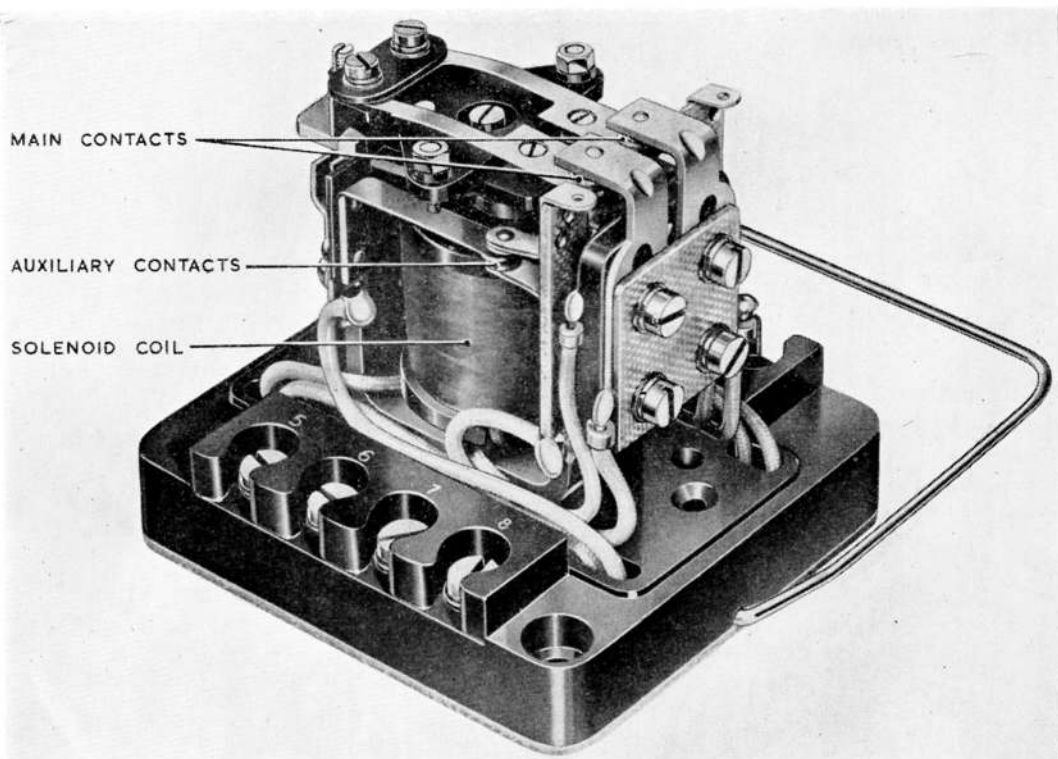

Fig. 1. Type 2A, No. 1 magnetic switch

Introduction

1. This magnetic switch (*fig. 1*), in common with others in the F3100 Series, is designed for use in 24 volt aircraft electrical systems.

DESCRIPTION

2. The Type 2A, No. 1 switch is physically similar to that which is described in A.P.4343, Vol. 1, Sect. 11, Chap. 3, and is used as a simple relay for 28 volt operation.

3. No swamping or economy resistors are fitted, the contacts across terminals 7 and 8 (*fig. 2*) being employed as auxiliary contacts. The ON/OFF contacts referred to in the above mentioned chapter are not used and the coil resistance is 179 ohm. All contacts are rated at 5 amp.

4. Details of functioning, installation and servicing for this switch are as given in the general chapter for the F3100 Series (*para. 2*).

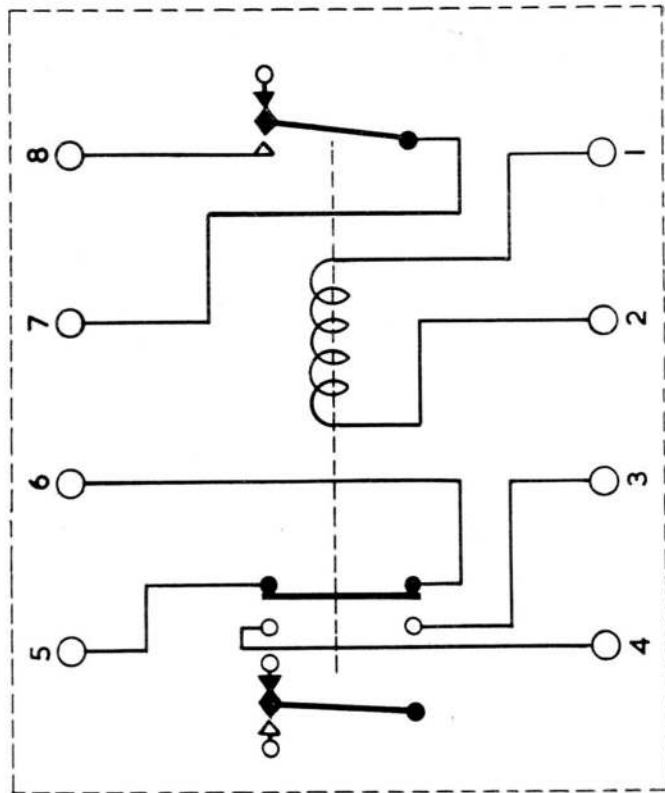

Fig. 2. Diagram of connections

RESTRICTED

This file was downloaded
from the RTFM Library.

Link: www.scottbouch.com/rtfm

Please see site for usage terms,
and more aircraft documents.

