

Chapter 48

CONTACTOR, B.T.H, TYPE LDC200-B2/5

LIST OF CONTENTS

	Para.		Para.
Introduction	1	Installation	8
Description	2	Servicing	10

LIST OF ILLUSTRATIONS

	Fig.		Fig.
Contactor, Type LDC200-B2/5	1	Details of latching mechanism	3
Sectional view of contactor	2	Circuit diagram	4

LEADING PARTICULARS

Contactor, Type LDC200-B2/5 ...	Stores Ref. 5CW/5498
Rated voltage (main contacts) ...	28 volts d.c. (30 volts max.)
Rated current	200 amp.
Rating of auxiliary contacts	30 volts d.c., 5 amp.
Voltage drop across contacts at rated current—	
Main contacts	100 mV (approx.)
Auxiliary contacts	75 mV (approx.)
Control voltage	16-30 volts d.c.
Coil current at 28 volts d.c.—	
Main relay coil	9 amp. (approx.)
Latching relay coil	8 amp. (approx.)
Weight	4 lb. 8 oz.
Dimensions of case	7 $\frac{3}{4}$ in. x 4 in. x 3 $\frac{1}{2}$ in.

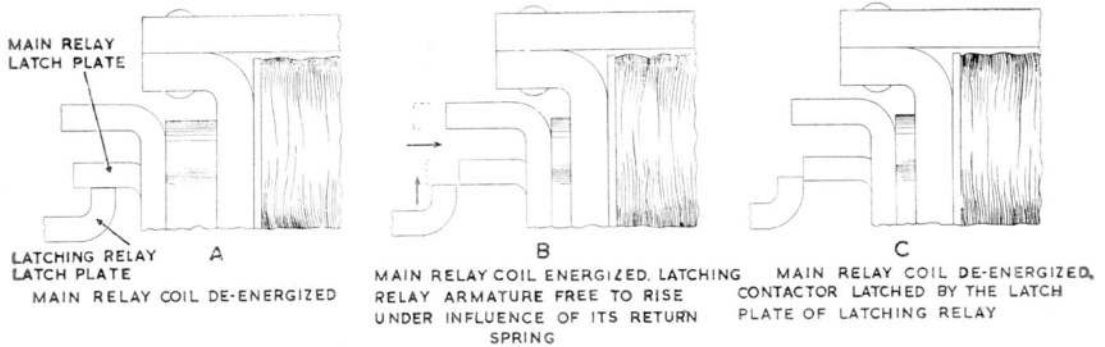

Fig. 3. Details of latching mechanism

reaches its fully operated position, the resulting latch clearance allows the latching relay armature to rise under the influence of its return spring (B). The latching plates are now so disposed that when the main relay is de-energized, its armature is prevented from returning to the unoperated position, i.e., the contactor is latched (C).

5. When the contactor is to be tripped, the operating coil of the latching relay is energized by application of a voltage across terminals 5 and 6. Its armature is attracted downwards, and allows the main relay to move under the influence of its return spring, thus operating the main contacts.

6. To prevent undue wear and to relieve the friction between the latching plates the main relay is, at the instant of tripping, momentarily energized through the contacts of the miniature switch mounted above the latching relay. Thus the main relay armature is drawn forward a little to allow the latching relay armature to move down freely. To limit the current drawn by both relay coils in parallel, a resistor is connected to terminal 6 in series with the tripping circuit.

7. A pair of auxiliary contacts, shown in fig. 4, is operated by the latching relay armature, and closes as the contactor trips. These contacts are used for external control or indicating purposes. A further pair of contacts in each relay circuit is operated by the armature of the other relay. The function of these contacts is to cut the relay coils out of circuit as soon as they have performed their allotted duty.

INSTALLATION

8. The contactor is normally installed with the mounting face horizontal, but if a vertical

mounting position is essential, the main terminals should be at the bottom. The contactor is weatherproof, but should, as far as possible, be mounted in a position free from direct splash, leakage of tanks, etc.

9. In a location subject to continued vibration, such as engine nacelles, it should be mounted on rubber or some other resilient mounting. In such instances, it should be ensured that the heavy-current cables cannot vibrate independently of the contactor, causing loose connections and terminal wear.

SERVICING

10. The cover should be removed periodically and the interior inspected for general cleanliness and freedom from deterioration of insulation, gaskets, etc. Check all screws and nuts for tightness, and leads for security of connection.

11. Press home the main relay armature manually, and check that the latching mechanism is operating correctly.

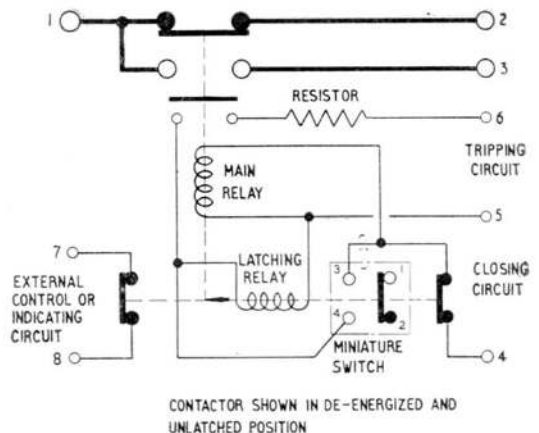

Fig. 4. Circuit diagram

(A.L.69, July 56)

This file was downloaded
from the RTFM Library.

Link: www.scottbouch.com/rtfm

Please see site for usage terms,
and more aircraft documents.

