

Chapter 68

SWITCH, MAGNETIC, TYPE 12B (ROTAX FI709)

LIST OF CONTENTS

	Para.		Para.
Introduction	1	Servicing	3
Description	2	Insulation resistance tests	4

LIST OF ILLUSTRATIONS

	Fig.		Fig.
Type 12B magnetic switch	1	Diagram of internal connections	2

LEADING PARTICULARS

Switch, magnetic, Type 12B	Stores Ref. 5CW/4760
Pull-in current (contacts close)	180-200 amperes
Release current (contacts open)	80-90 amperes
Length	3-650 in.
Width	3-218 in.
Height	3-419 in.
Weight	1 lb. 2 oz.

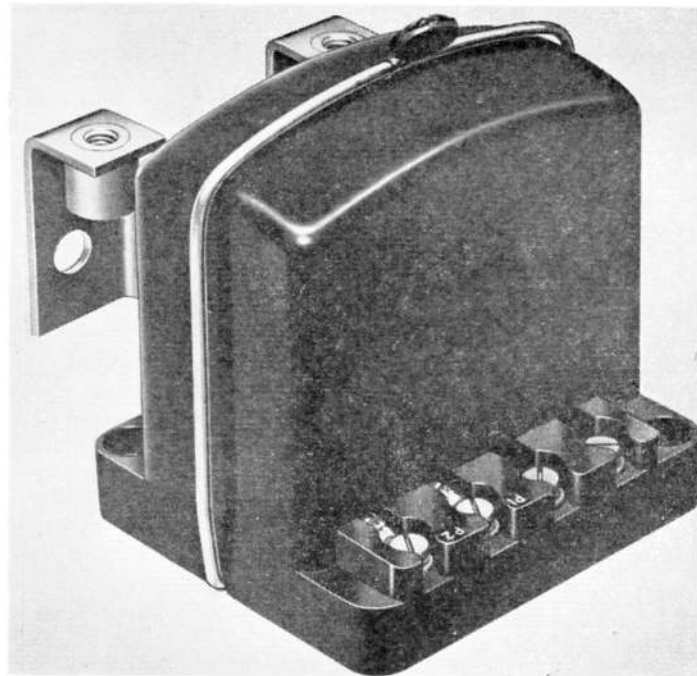

Fig. 1. Type 12B magnetic switch

Introduction

1. This unit is generally similar to others in the F1700 series of overspeed relays described in A.P.4343, Vol. 1, Sect. 11, Chap. 2, with the exception that there is no shunt winding, the operation of the contacts being controlled entirely by the current flowing in the series winding.

DESCRIPTION

2. The Type 12B magnetic switch is an overspeed relay, similar in construction and operation to the general type described in A.P.4343, Vol. 1, Sect. 11, Chap. 2, which also contains details of installation. This unit, however, has only a series winding which consists of approximately two turns of insulated copper strip. There is an air gap between the winding and the core. The relay operates without a diverter bar between the main positive and negative terminals.

SERVICING

3. The inspection, contact cleaning procedure and voltage drop test described in A.P.4343, Vol. 1, Sect. 11, Chap. 2, paras. 7, 8 and 9, apply to the F1709 relay. The insulation resistance should, however, be tested as described in para. 4, below.

Insulation resistance test

4. Measure the insulation resistance between the iron yoke and the main terminals and between the yoke and terminals 1 and 2,

using a 250-volt insulation resistance tester. A reading of not less than 50,000 ohm should be obtained in each test.

Note . . .

The value of insulation resistance given in para. 4 applies to units being tested under normal workshop conditions. Due allowance should be made for climatic conditions of the locality and those of the aircraft servicing area or dispersal point where tests are being applied. In particularly damp climates, the readings may be low enough to give apparently sufficient reason for rejection and, in these instances, discretion should be exercised.

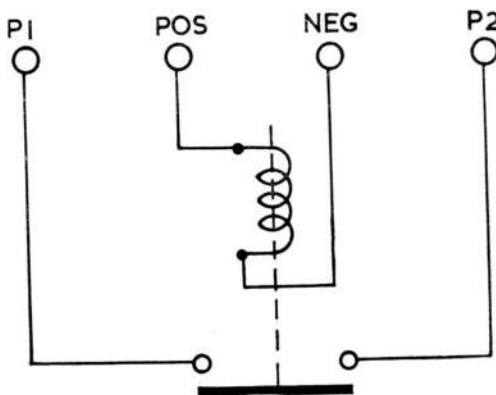

Fig. 2. Diagram of internal connections

RESTRICTED

This file was downloaded
from the RTFM Library.

Link: www.scottbouch.com/rtfm

Please see site for usage terms,
and more aircraft documents.



**TELEBRIEF
CONNECTIONS**

E