

## Chapter 70

### SINGLE RELAY PANEL UNIT, DOWTY, TYPE C5101Y, Mk. 2

#### LIST OF CONTENTS

	Para.		Para.
Introduction ... ..	1	Installation ... ..	8
Description ... ..	2	Servicing ... ..	9
Operation ... ..	4		

#### LIST OF ILLUSTRATIONS

	Fig.		Fig.
Single relay panel unit, Type C5101Y, Mk. 2 ...	1	Circuit diagram ... ..	2

#### LEADING PARTICULARS

Type C5101Y, Mk. 2 ... ..	Stores Ref. 5CW/5149
Operating voltage ... ..	24 d.c.
Weight ... ..	1.3 lb. (approx.)
Mounting flange ... ..	4.12 in. × 4.12 in.
Overall depth (excluding mountings) ... ..	3.13 in.

#### Introduction

1. The single relay panel unit, Type C5101Y, Mk. 2, is used in conjunction with the stepless drum switch, Type C1837Y, in the control

circuit for dive brakes operation. It incorporates in one unit the various relays and trimmer resistors which are required in that circuit. A description of the drum switch, Type C1837Y, will be found in Sect. 1 of this publication.

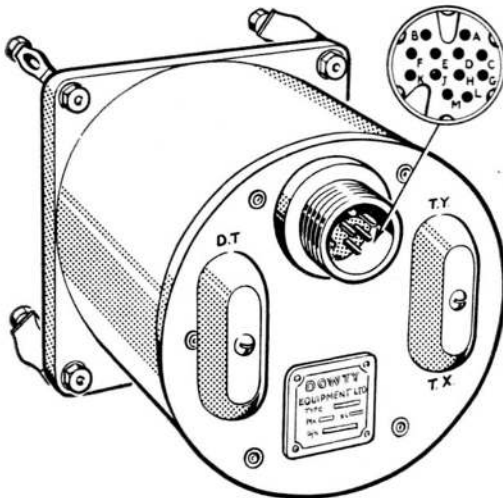

Fig. 1. Single relay panel unit, Type C5101Y, Mk. 2

#### DESCRIPTION

2. A general view of the unit is shown in fig. 1, and the circuit diagram in fig. 2. The unit differs from other Marks of the same type number in respect of the fitting of certain trimmer resistors, and in the number of contacts in the slave relays.

3. Three trimmer resistors are fitted on this unit. Trimmer DT, shown on the left in fig. 1, is used to de-sensitize the polarized control relay. The trimmer on the right is a combined trimmer, TX and TY, used to adjust the dive brake position indicator.

#### Operation

4. Two switches, Type C1837Y, are normally used in the dive brakes control circuit, one operated by the pilot's dive brake selector and the other directly by the dive brakes.

(A.L.86, Nov. 56)

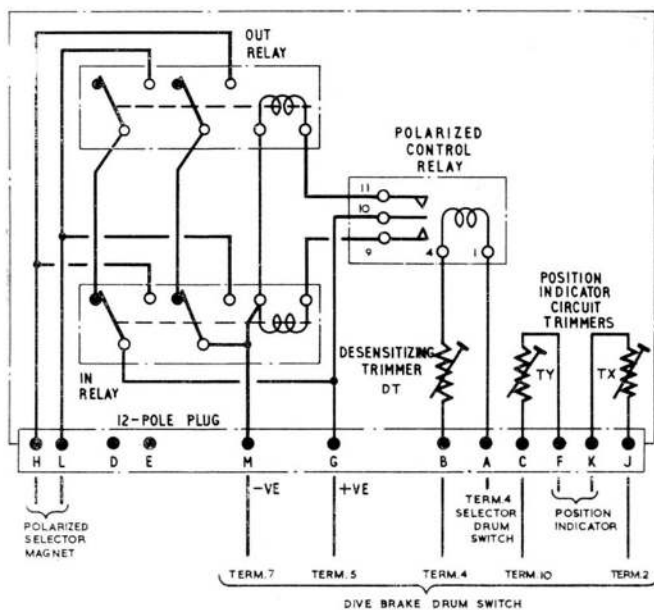

Fig. 2. Circuit diagram

Each switch is virtually a potentiometer connected between the positive supply and earth; the moving contacts are interconnected through the coil of a polarized control relay. The control system thus forms a Wheatstone bridge circuit with the polarized relay sensing the out-of-balance current between the two driven arms.

5. If the pilot's selector is moved backwards or forwards (i.e., towards IN or OUT), the moving contacts on the switches are, initially, in different positions relative to each other. A potential difference thus exists between them, and current flows through the polarized relay coil, the direction of flow depending on the polarity of the P.D., determined by the direction of movement of the pilot's selector lever. If the lever has been moved towards OUT, the direction of the energizing current is such as to close a pair of contacts feeding an OUT slave relay; if it has been moved towards IN, an IN slave relay is energized. Energization of the slave relay completes the circuit to the polarized selector magnet and the dive brakes start to move towards the position selected.

6. As the dive brakes move towards the selected position, thus driving the moving contact of the second drum switch, the P.D. between the two arms becomes less until the current is insufficient to energize the polarized relay; at this point the two switches are virtually in step again. The relay therefore becomes de-energized, and the dive brakes remain in the selected position.

7. The second winding on the drum switch which is operated by the dive brakes is used for transmitting dive brakes position to a position indicator on the pilot's panel.

#### INSTALLATION

8. The unit has a square mounting flange, provided with four rubber mountings complete with 4 B.A. nuts and washers. For details of a particular installation, reference should be made to the relevant Aircraft Handbook.

#### SERVICING

9. No servicing is possible on this unit, apart from an inspection for security of connections and freedom from damage; a faulty unit must be renewed.

RESTRICTED

This file was downloaded  
from the RTFM Library.  
Link: [www.scottbouch.com/rtfm](http://www.scottbouch.com/rtfm)

Please see site for usage terms,  
and more aircraft documents.

