

Chapter 72

MAGNETIC RELAY SWITCH, TYPE 4184GD

LIST OF CONTENTS

	Para.		Para.
Introduction	1	Installation	6
Description	2	Servicing	7

LIST OF ILLUSTRATIONS

	Fig.		Fig.
Magnetic relay switch, Type 4184GD	1	Circuit diagram	3
Internal construction of relay	2		

LEADING PARTICULARS

	Inter-Service Ref. Z530453
Nominal voltage	24 d.c.
Standard voltage limits	19.2 to 28.8 volts
Coil resistance at 15 deg. C.	700 ohms \pm 5 per cent
Minimum circuit voltage	19 volts
Minimum circuit current	21 mA
Maximum contact current	2 amp.
Weight	1.75 oz.
Dimensions:—	
Height	1.125 in.
Width	0.812 in.
Length (over fixing studs)	2.031 in.

Introduction

1. The magnetic relay switch, Type 4184GD, is a sealed, double-contact change-over midget type relay for light duty applications where the contact current does not exceed 2 amp.

DESCRIPTION

2. A general view of the relay is given in fig. 1, and a view of the internal construction in fig. 2. It incorporates a base plate, a magnet frame with coil and armature, and a contact set. The base plate, which carries two fixing studs, is drilled to accommodate the eight glass insulators for the contact pins. Mounted on its upper side is a bracket, to which are attached the magnet frame, coil, armature and spring set.

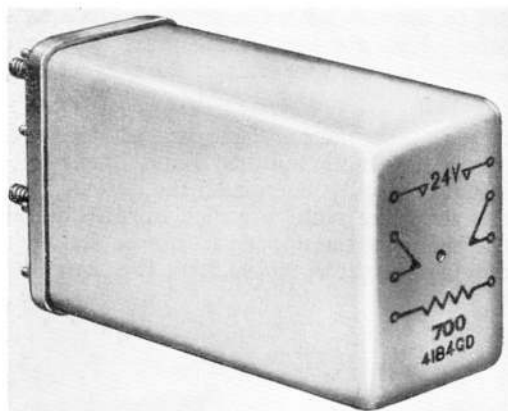

Fig. 1. Magnetic relay switch, Type 4184GD

(A.L.88, Dec. 56)

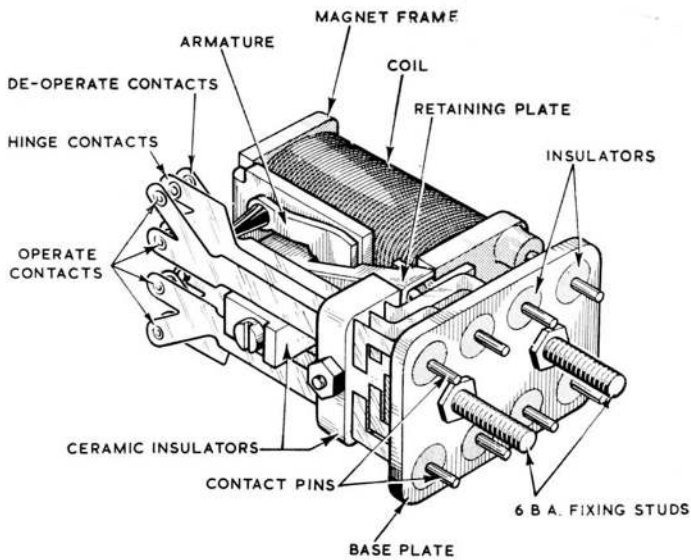

Fig. 2. Internal construction of relay

3. The armature, which bridges the pole gap of the magnet, consists of a slightly dished plate bearing against the side of a yoke, the bowed portion serving as a pivot. The upper wider part of the armature carries two operating buffers, these acting on to two extensions of the centre spring blades.

4. The spring set of six blades is held in position by two ceramic insulating blocks, the upper one also serving to locate the armature retaining plate. The spring blades are forked at their top end to carry twin contacts of a precious metal suitable for switching V.F. and R.F. circuits at a low power level, whilst the bottom ends are offset to connect with the six respective base pins. The two remaining base pins are soldered to the wire ends of the magnet coil.

5. In its normal unoperated position (fig. 3), contacts 2 and 3, 6 and 7 are made. When the coil is energized, the lower end of the armature plate is pulled inwards across the pole gap, the upper part above the hinge moving outwards, so breaking the normally-

made contacts and making contacts 3 and 4, 5 and 6. When the coil is de-energized, the contacts return to their normal, unoperated position.

INSTALLATION

6. The relay is provided with two 6 B.A. mounting studs. If required, it can be plugged into a special socket.

SERVICING

7. Since this is a sealed relay, no servicing is possible, apart from a general inspection for freedom from damage and security of connections.

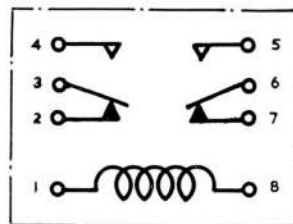

Fig. 3. Circuit diagram

This file was downloaded
from the RTFM Library.

Link: www.scottbouch.com/rtfm

Please see site for usage terms,
and more aircraft documents.

