

Chapter 77

MAGNETIC SWITCH, TYPE 16B, No. 1 (PAGE RH12)

LIST OF CONTENTS

	Para.		Para.
Introduction...	1	Servicing ...	5
Description ...	2		

LIST OF ILLUSTRATIONS

	Fig.		Fig.
Magnetic switch, Type 16B, No. 1 ...	1	Circuit diagram ...	2

LEADING PARTICULARS

Magnetic switch, Type 16B, No. 1 ...	Stores Ref. 5CW/5528
Voltage ...	24 d.c.
Coil resistance at 15.6 deg. C. ...	670 ohms \pm 5 per cent
Contact rating ...	4 amp. at 60V d.c. 2 amp. at 300V d.c. 4 amp. at 300V a.c.
Overall dimensions—	
Length ...	3 $\frac{5}{8}$ in.
Width ...	1 $\frac{3}{8}$ in.
Height ...	3 $\frac{1}{8}$ in.
Weight ...	8 $\frac{1}{2}$ oz.
Minimum circuit current ...	21.4 mA

Introduction

1. The magnetic switch, Type 16B, No. 1, is a sealed, miniature type relay with heavy-duty contacts; the contact arrangement is two break, two make.

DESCRIPTION

2. This switch (*fig. 1*) consists of a sealed relay, Type M1095 (Inter-Service Ref. Z530032) secured to a moulded Bakelite base plate having shrouded 6 B.A. terminals. The switch is designed for panel mounting, and is provided with three anti-vibration mountings incorporating 4 B.A. fixing studs.

3. The miniature relay, Type M1095, incorporates an L-shaped pole piece, reduced in

thickness at the armature end to form a step into which the armature fits and pivots on a flat spring attached to the pole piece. An extension on the armature passes along a slot in the long side of the pole piece, and an operating arm, riveted to the armature extension, operates the moving springs of the relay.

4. The springset is built up of flat springs with silver-nickel contacts, and the complete assembly is fixed to the armature end of the pole piece. The coil is single wound, and, when energized, attracts the armature to operate the contacts.

SERVICING

5. Since the switch mechanism is sealed, no servicing is possible apart from a general inspection for freedom from damage and security of connections. The minimum circuit current of 21.4 mA quoted under

Leading Particulars is that current which must normally be available for operation to ensure an adequate factor of safety; the switch should operate when a test current of 20 mA is applied to terminals a and b.

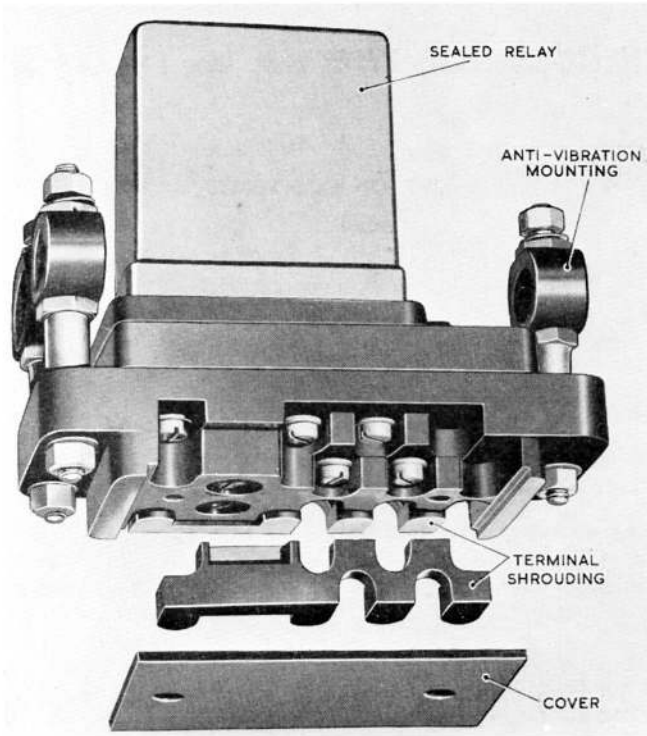

Fig. 1. Magnetic switch, Type 16B, No. 1

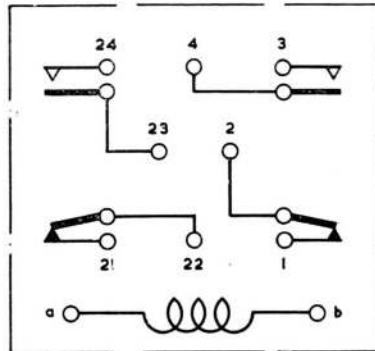

Fig. 2. Circuit diagram

RESTRICTED

This file was downloaded
from the RTFM Library.
Link: www.scottbouch.com/rtfm

Please see site for usage terms,
and more aircraft documents.

