

Chapter 14

SWITCH, MAGNETIC, TYPE 6A, No. 5 (ROTAX D9011/2)

LIST OF CONTENTS

	Para.		Para.
Introduction	1	Coil resistance test	5
Description	2	Coil pull-in voltage test	6
Electrical connections	3	Millivolt drop test	7
Servicing	4	Insulation resistance tests	9

LIST OF ILLUSTRATIONS

	Fig.		Fig.
Magnetic switch Type 6A, No. 5	1	Diagram of internal connections	2

LEADING PARTICULARS

Switch, magnetic, Type 6A, No. 5	Stores Ref. 5CW/5048
Voltage:—	
Main and shunt field contacts	112-V. d.c.
Auxiliary switches	28-V. d.c.
Operating coils	28-V. d.c.
Current rating:—	
Main contacts	60 amperes
Shunt field contacts	2.5 amperes
Auxiliary switches	5 amperes
Rating	2 min. maximum
Resistance of coils at 20 deg. C.	15 ohm \pm 10 per cent.
Operational temperature range	-65 deg. C. to + 70 deg. C.
Operational ceiling	50,000 ft.
Length	6.880 in.
Width	3.520 in.
Height	3.800 in.
Weight	4.25 lb.

Introduction

1. This magnetic switch, in common with others in the D.9000 series, is designed for use in 112-V. d.c. installation, where a double-pole reversing contactor is required for short rated duties e.g., to reverse the direction of rotation of an actuator motor.

DESCRIPTION

2. The Type 6A No. 5 switch (fig. 1) is identical to that described in A.P.4343, Vol. 1, Sect. 11, Chap. 12. Its auxiliary switches (terminals 1 and 2, 3 and 4) are normally open, as indicated in fig. 2.

Electrical connections

3. The main terminals are of two different sizes in order to provide a safeguard against incorrect connection. Terminals "A1" and "+" are $\frac{1}{4}$ in. B.S.F. studs whilst terminals "A2" and "F" are 2 B.A. studs. Other connections are made to 4 B.A. combined screw and washer terminations.

SERVICING

4. Make a visual inspection of the switch to ensure that it has sustained no damage and that it is secure on its mounting. Ensure that the terminals are clean and the external connections are secure. Remove the switch covers and examine the contacts for pitting and burning; the results of this inspection, a check to ensure that full follow-through is available and the millivolt drop tests (para. 7) should be taken into account when deciding if the contacts have ended their useful life.

Coil resistance test

5. Measure the resistance of the coils between terminals C1 and C2; C3 and C4. When corrected to 20 deg. C., each reading should be between 13.5 ohm and 16.5 ohm.

Coil pull-in voltage test

6. The minimum current required to operate each coil should be between 0.73 ampere and 0.95 ampere. The product of this minimum current and the exact resistance of the coil (para. 5) should not exceed 15.7 volt.

WARNING

An interlock exists to prevent both sets of contacts closing at the same time. Therefore, before energizing a coil, ensure that the remaining coil is de-energized.

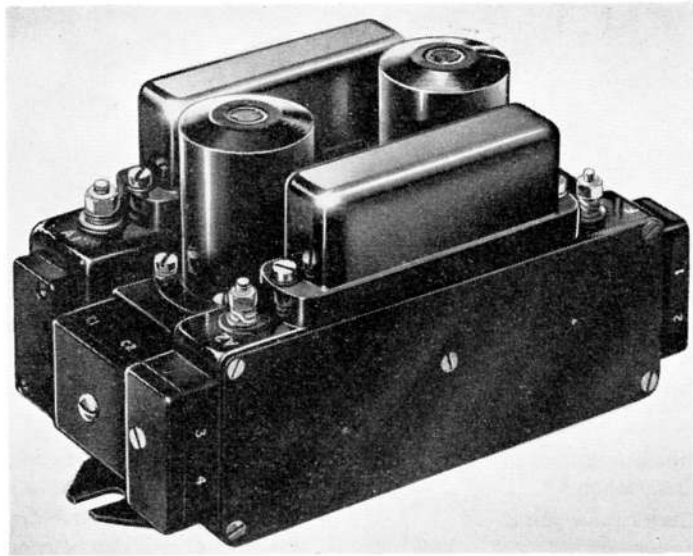

Fig. 1. Magnetic switch Type 6A, No. 5

Note . . .

Any movement of the contact arms to the extent of closing the contacts must always produce the correct amount of follow through. (Moving contact "A1" and moving contact "+" 0.035 in. to 0.040 in.; moving contact "A2" and moving contact "F" 0.025 in. to 0.030 in.).

Millivolt drop test

7. Allow the rated current of 60 amperes to flow through each 112-volt path (the coil with terminals C1, C2 to be energized). Measure the potential drop across the following points; readings obtained should not exceed the values indicated.

- | | |
|---|---------------|
| (1) Across each mating pair of contacts | 35 millivolt |
| (2) Across each braid | 60 millivolt |
| (3) Across terminals A1 and + | 170 millivolt |
| (4) Across terminals A2 and F | 170 millivolt |

De-energize the coil (terminals C1 and C2) and energize the other coil (terminals C3, C4). Make the following potential drop tests.

- | | |
|---|---------------|
| (5) Across terminals A1 and F | 170 millivolt |
| (6) Across terminals A2 and + | 170 millivolt |

8. The potential drop across terminals 1 and 2 and across terminals 3 and 4 should not exceed 40 millivolt with 5 amperes flowing through the auxiliary contacts. The potential

RESTRICTED

drop across each mating pair of shunt field contacts should not exceed 10 millivolt with 25 amperes flowing.

Insulation resistance tests

9. Measure the insulation resistance between the following points using a 500-V. insulation resistance tester. A reading of not less than 50,000 ohm should be obtained in each test.

- (1) Terminal A1 and terminals A2, F, +, SHF, 1, 2, 3, 4, C2 and C4.
- (2) Terminal A2 and terminals F, +, SHF, 1, 2, 3, 4, C2 and C.
- (3) Terminal F and terminals +, SHF, 1, 2, 3, 4, C2 and C4.
- (4) Terminal + and terminals SHF, 1, 2, 3, 4, C2 and C4.
- (5) Terminal SHF and terminals 1, 2, 3, 4, C2 and C4.

Measure the insulation resistance between the following points using a 250-V. insulation resistance tester. A reading of not less than 50,000 ohm should be obtained in each test.

- (6) Terminal 1 and terminals 2, 3, 4, C2 and C4.
- (7) Terminal 2 and terminals 3, 4, C2 and C4.
- (8) Terminal 3 and terminals 4, C2 and C4.

- (9) Terminal 4 and terminals C2 and C4.
- (10) Terminal C2 and terminal C4.

Note . . .

The value of insulation resistance given in para. 9 applies to units being tested under normal workshop conditions. Due allowance should be made for climatic conditions of the locality and of the aircraft servicing area or dispersal point. In particularly damp climates, the readings may be low enough to give apparent cause for rejection, and in these instances discretion should be exercised.

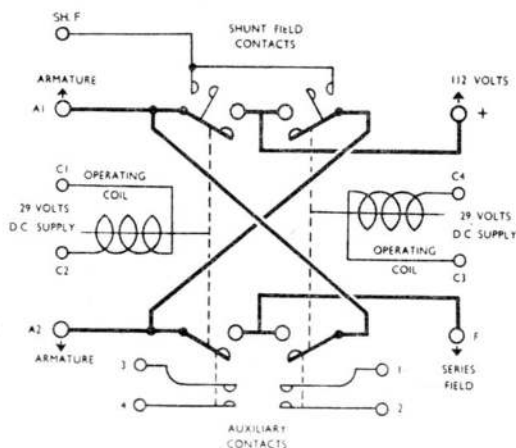

Fig. 2. Diagram of internal connections

This file was downloaded
from the RTFM Library.

Link: www.scottbouch.com/rtfm

Please see site for usage terms,
and more aircraft documents.

