

Chapter 34

SWITCH, MAGNETIC, TYPE 3Y, No. 2 (ROTAX D.6704/2)

LIST OF CONTENTS

	Para.		Para.
Introduction	1	Servicing	4
Description	2	Millivolt drop test	5
Installation	3	Insulation resistance tests	7

LIST OF ILLUSTRATIONS

	Fig.		Fig.
Type 3Y, No. 2 magnetic switch	1	Diagram of internal connections	2

LEADING PARTICULARS

Switch, magnetic, Type 3Y, No. 2	Stores Ref. 5CW/4779
Voltage	
Main contacts	208-V. 400 c.p.s. 3-phase a.c.
Coil	28-V. d.c.
Current rating... ..	40 amperes
Rating	Continuous
Coil resistance at 20 deg. C.	
Pull-in	6.8 ohm \pm 5 per cent
Hold-in (total)	76 ohm \pm 5 per cent
Operational temperature range	— 65 deg. C. to + 70 deg. C.
Operational ceiling	60,000 ft.
Length	4.312 in.
Width	2.957 in.
Height	3.000 in.
Weight	2 lb.

Introduction

1. The Type D.6704/2 magnetic switch is generally similar to others in the D.6700 series described in A.P.4343, Vol. 1, Sect. 11, Chap. 20. The main contact voltage is 208-V., 400 c.p.s. 3-phase a.c. and the current rating is 40 amperes per line. There is one pair of normally open auxiliary contacts having a rating of 5 amperes, for use in a 28-V. d.c. circuit.

DESCRIPTION

2. Full details of description and operation will be found in A.P.4343, Vol. 1, Sect. 1, Chap. 20.

INSTALLATION

3. The main terminals are standard 37 ampere S.B.A.C. sockets and the coil terminals

and auxiliary switch terminals are standard 4 ampere S.B.A.C. sockets.

SERVICING

4. In addition to the servicing detailed in A.P.4343, Vol. 1, Sect. 11, Chap. 20, Paras. 10 to 12, the following tests should be applied.

Millivolt drop test

5. Allow 40 amperes d.c. to flow between each opposite pair of main terminals in turn (coil energized). The potential drop across each pair of mating contacts should not exceed 15 millivolt and the potential drop across each opposite pair of terminals should not exceed 70 millivolt.

(A.L.95, Feb. 57)

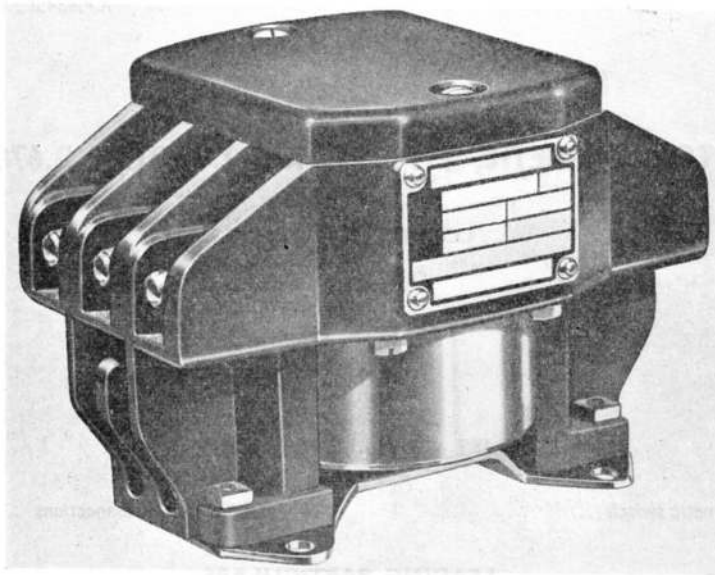

Fig. 1. Type 3Y, No. 2 magnetic switch

6. With 5 amperes flowing (coil energized), the potential drop across the auxiliary switch terminals should not exceed 150 millivolt.

Insulation resistance tests

7. Measure the insulation resistance between the following points, using a 500-V. insulation resistance tester. A reading of not less than 50,000 ohms should be obtained in each test.

- (1) Main contacts open
 - (a) Terminal A and terminal L1.
 - (b) Terminal B and terminal L2.
 - (c) Terminal C and terminal L3.
- (2) Main contacts closed
 - (a) Terminal A and terminal B
 - (b) Terminal A and terminal C
 - (c) Terminal B and terminal C
 - (d) Frame and terminals A, B and C
 - (e) Terminal CT and terminals A, B and C
 - (f) Terminal IN.1 and terminals A, B and C

8. Measure the insulation resistance between the following points, using a 250-V. insulation resistance tester. A reading of at least 50,000 ohm should be obtained in each test.

- (1) Main contacts open
 - (a) Terminal IN.1 and terminal IN.2.

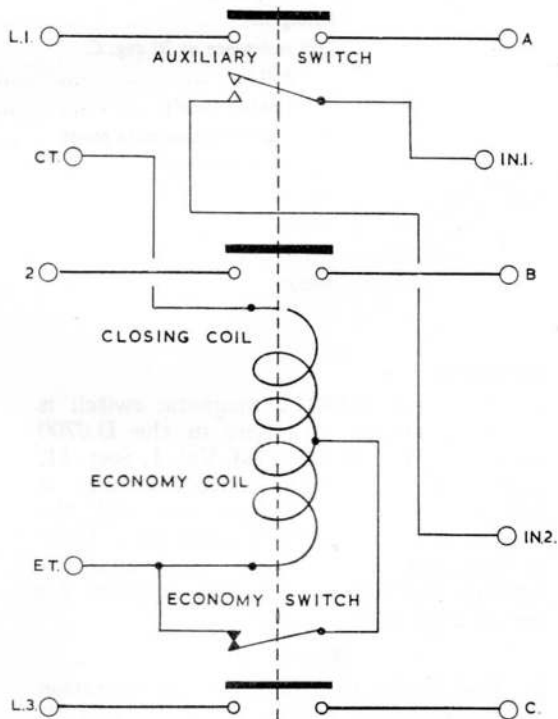

Fig. 2. Diagram of internal connections

- (2) Main contacts closed
 - (a) Terminal IN.1 and terminal CT.
 - (b) Terminals IN.1 and CT. and frame.

Note . . .

The values of insulation resistance given in paras. 7 and 8 apply to switches being tested under normal workshop conditions.

Due allowance should be made for the climatic conditions of the locality and those of the aircraft servicing area or dispersal point where the tests are being applied. In particularly damp climates, the readings may be low enough to give apparently sufficient reason for rejection and, in these instances, discretion should be exercised.

This file was downloaded from the RTFM Library.
Link: www.scottbouch.com/rtfm

Please see site for usage terms, and more aircraft documents.

