

Chapter 45

CONTACTOR, B.T.H., TYPE LDA150-AI/1

LIST OF CONTENTS

	Para.		Para.
Introduction	1	Installation	8
Description	2	Servicing	10

LIST OF ILLUSTRATIONS

	Fig.		Fig.
Contactor, Type LDA150-AI/1	1	Details of latching mechanism	3
Sectional view of contactor	2	Circuit diagram	4

LEADING PARTICULARS

Contactor, Type LDA150-AI/1	Stores Ref. 5CW/5775
Rated voltage (main contacts)	112 volts d.c. (126 volts max.)
Rated current	150 amp. (cont.)
Rating of auxiliary contacts	29 volts d.c., 5 amp.
Voltage drop across contacts at rated current—	
Main contacts	less than 150 mV
Auxiliary contacts	less than 75 mV
Control voltage	16-29 volts d.c.
Coil current at 24 volts d.c.—	
Main relay coil	12 amp. (approx.)
Latching relay coil	8 amp. (approx.)
Weight	4 lb. 8 oz.
Dimensions of case	$7\frac{3}{8}$ in. x $3\frac{3}{8}$ in. x $3\frac{1}{2}$ in.

Introduction

1. The contactor, Type LDA150-A1/1 (fig. 1), is a single-pole, single-throw contactor which is electrically controlled and mechanically latched. It can be operated by a remote switch, and is designed for the control of circuits carrying up to 150 amp. continuously at a normal voltage of 112 volts d.c. Since it is latched mechanically, it is dependent on the nominal control supply of 24 volts d.c. only during the moment of opening or closing of the main contacts.

DESCRIPTION

2. A sectional view of the contactor is shown in fig. 2. It incorporates two electromagnetic relays, the main relay with its armature axis horizontal, and a latching relay with its armature axis vertical.

3. When the main relay is energized by the application of a voltage across terminals 7 and 8, its armature is attracted to the closed position against the action of a return spring. As the armature moves, the contact carrier,

which is fixed to its end, meets the fixed contacts. The armature then continues its movement until it is fully home, so giving the necessary over-travel.

4. The operation of the latching mechanism is shown in fig. 3, with A the position of the plates when the main relay coil is un-energized. When the main relay armature

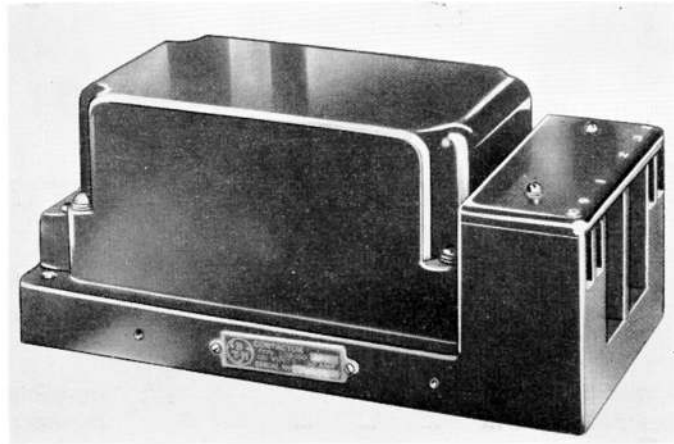

Fig. 1. Contactor, Type LDA150-A1/1

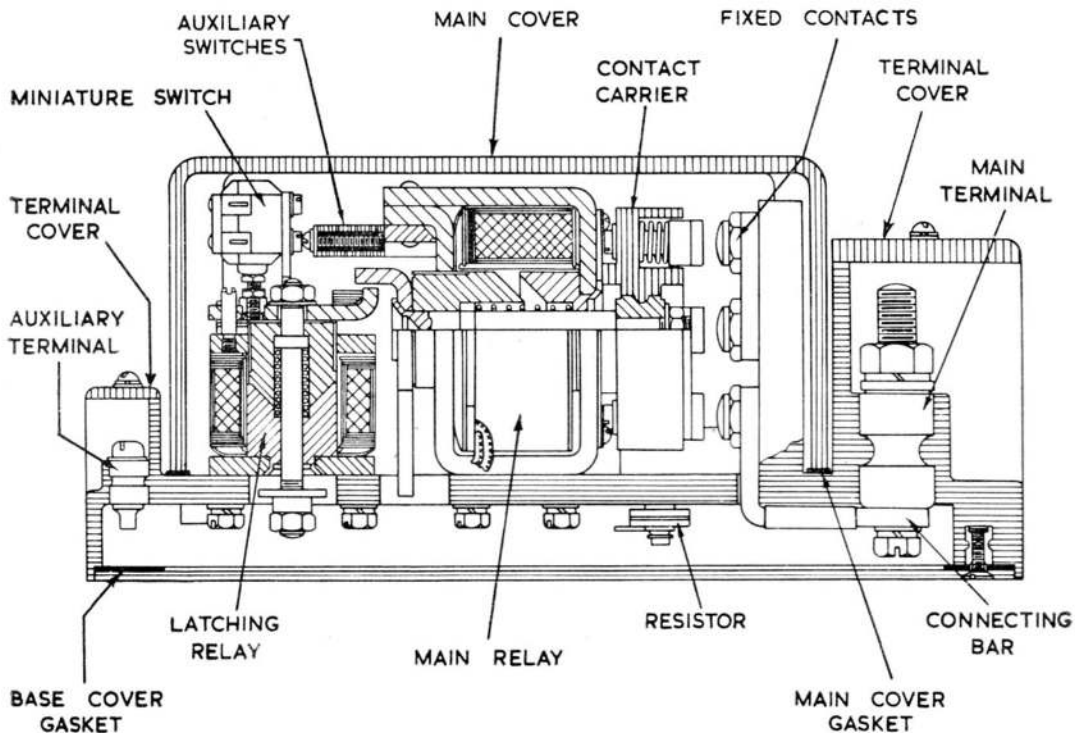

Fig. 2. Sectional view of contactor

RESTRICTED

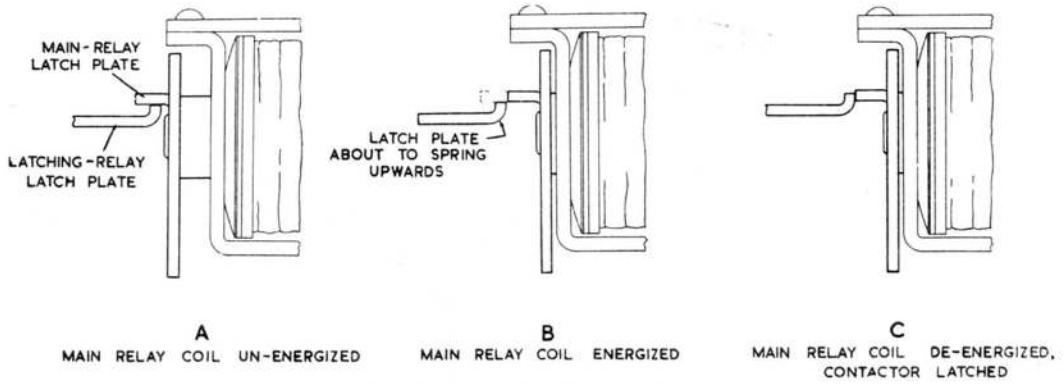

Fig. 3. Details of latching mechanism

reaches its fully operated position, the resulting latch clearance allows the latching relay armature to rise under the influence of its return spring (B). The latching plates are now so disposed that when the main relay is de-energized, its armature is prevented from returning to the unoperated position, i.e., the contactor is latched.

5. When the contactor is to be tripped, the operating coil of the latching relay is energized by application of a voltage across terminals 9 and 10. Its armature is attracted downwards, and allows the main relay to move under the influence of its return spring, thus operating the main contacts.

6. To prevent undue wear and to relieve the friction between the latching plates the main relay is, at the instant of tripping, momentarily energized through the contacts of the miniature switch mounted above the latching relay. Thus the main relay armature is drawn forward a little to allow the latching relay armature to move down freely. To limit the current drawn by both relay coils in parallel, a resistor is connected to terminal 10 in series with the tripping circuit.

7. A number of auxiliary contacts, shown in fig. 4, are operated by the relays. One pair, connected to terminals 3 and 4, is operated by the main relay armature and closes as the main contacts meet; another pair, connected to terminals 5 and 6 and operated by the latching relay armature, closes as the contactor trips. Both are for external control or indicating purposes. A further pair of contacts in each relay circuit is operated by the armature of the other relay. The function of these contacts is to cut the relay coils out of circuit as soon as they have performed their allotted duty.

INSTALLATION

8. The contactor is normally installed with the mounting face horizontal, but if a vertical mounting position is essential, the main terminals should be at the bottom. The contactor is weatherproof, but should, as far as possible, be mounted in a position free from direct splash, leakage of tanks, etc.

9. In a location subject to continued vibration, such as engine nacelles, it should be mounted on rubber or some other resilient mounting. In such instances, it should be ensured that the heavy-current cables cannot vibrate independently of the contactor, causing loose connections and terminal wear.

SERVICING

10. The cover should be removed periodically and the interior inspected for general cleanliness and freedom from deterioration of insulation, gaskets, etc. Check all screws and nuts for tightness, and leads for security of connection.

11. Press home the main relay armature manually, and check that the latching mechanism is operating correctly.

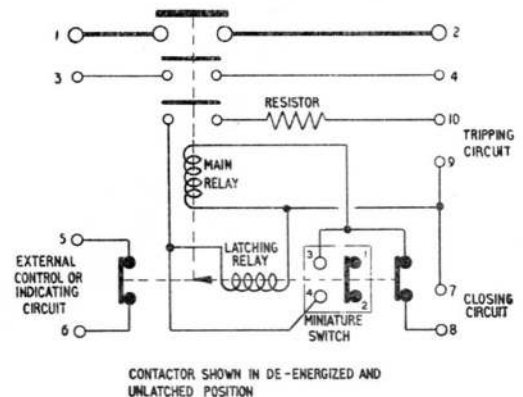

CONTACTOR SHOWN IN DE-ENERGIZED AND UNLATCHED POSITION

Fig. 4. Circuit diagram

(A.L.69, July 56)

This file was downloaded from the RTFM Library.
Link: www.scottbouch.com/rtfm

Please see site for usage terms, and more aircraft documents.

