

## Chapter 54

# SWITCH, MAGNETIC, ROTAX D9422/2

### LIST OF CONTENTS

	Para.		Para.
Introduction ... ..	1	Coil resistance test ... ..	7
Description ... ..	2	Millivolt drop tests ... ..	8
Operation ... ..	4	Insulation resistance tests ... ..	9
Servicing ... ..	6		

### LIST OF ILLUSTRATIONS

	Fig.		Fig.
D9422/2 magnetic switch ... ..	1	Diagram of internal connections ... ..	2

### LEADING PARTICULARS

<b>Voltage</b>	
Main contacts ... ..	112-V. d.c.
Auxiliary contacts ... ..	28-V. d.c.
Operating coil ... ..	28-V. d.c.
Resistance of operating coil at 20 deg. C. ...	3.7 ohm $\pm$ 5 per cent
<b>Current rating</b>	
Main contacts ... ..	80 amperes
Auxiliary contacts ... ..	5 amperes
Operational temperature range ... ..	-65 deg. C. to + 50 deg. C.
Operational ceiling ... ..	50,000 ft.
Length ... ..	5.500 in.
Width ... ..	5.437 in.
Height ... ..	5.062 in.
Weight ... ..	4 lb. 8 oz.

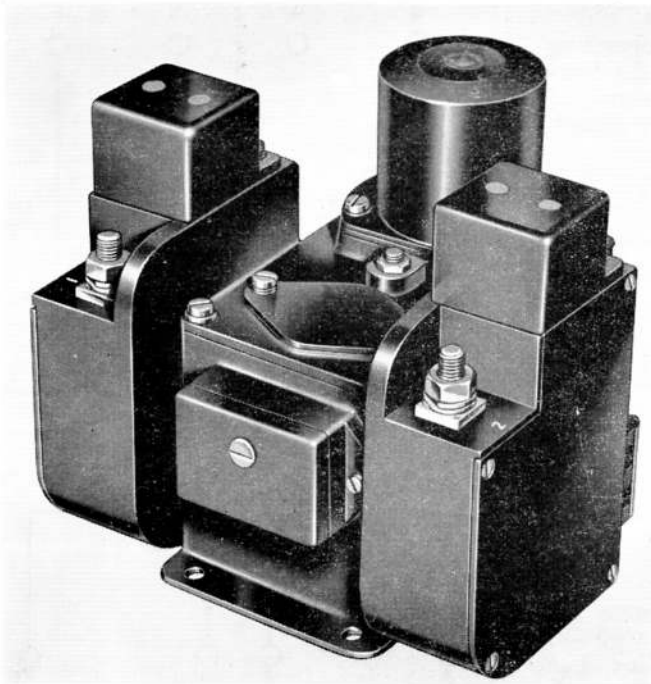

Fig. 1. D9422/2 magnetic switch

#### Introduction

1. The D9422/2 magnetic switch is a short-rated contactor for use in 112-V. d.c. circuits with currents up to 80 amperes. The contactor is similar in appearance to others in the D.9400 series (A.P.4343, Vol. 1, Sect. 11, Chap. 17) but does not latch, the main contacts remaining closed only as long as an adequate current is passed through the operating coil. There are two pairs of auxiliary contacts, both pairs normally closed.

#### DESCRIPTION

2. The following items, mentioned in A.P. 4343, Vol. 1, Sect. 11, Chap. 17, are not fitted to the D9422/2 magnetic switch.

- (1) Latch plate
- (2) Trip coil and mechanism
- (3) Trip coil safety switch
- (4) Operating coil safety (or economy) switch

(A.L.104, May 57)

- (5) Economy resistors
- (6) Bi-metal element
- (7) Interlock mechanism

3. The description given in A.P.4343, Vol. 1, Sect. 11, Chap. 17 of the main and auxiliary contacts, arc chutes, operating coil and toggle linkage, and the housings generally apply to this contactor. The linkage casing, which is standard throughout the series, has a blanking plate where, in other units the trip coil is mounted.

**Operation**

4. When 28-V. d.c. is applied to the operating coil (terminals 5 and 6) the solenoid plunger pulls the toggle linkage over-centre and all contacts are thereby closed. When supply is discontinued from the coil, the plunger is released, the toggle linkage collapses and all contacts revert to their normal (open) positions.

5. For further details of operation and installation, reference should be made to A.P.4343, Vol. 1, Sect. 11, Chap. 17.

**SERVICING**

6. The following tests should be applied to the contactor in addition to the general inspection mentioned in A.P.4343, Vol. 1, Sect. 11, Chap. 17, Para. 10. *The inter-lock resetting procedure described in Para. 11 of the same chapter does not apply to this contactor.*

**Coil resistance test**

7. Measure the resistance of the operating coil between terminals 5 and 6 of the four-pole terminal block (fig. 3), when corrected to 20 deg. C. ambient temperature, the reading should be 3.7 ohm  $\pm$  5 per cent.

**Millivolt drop tests**

8. Allow the rated current of 80 amperes to flow through the main circuit (main contacts closed) and measure the potential drops enumerated below. They should not exceed the values given.

- (1) across each pair of main contacts 20 millivolt
- (2) across each flexible braid 20 millivolt
- (3) across each joint 5 millivolt
- (4) across the main terminals 115 millivolt

With 5 amperes flowing, the potential drop between the terminals of each auxiliary switch should not exceed 20 millivolt.

**Insulation resistance tests**

9. Measure the insulation resistance between the following points, using a 500-V. insulation resistance tester. A reading of at least 50,000 ohm should be obtained in each test.

- (1) Main contacts closed
  - (a) Terminal 1 and terminals 5, 7, 8, 9 and 10
  - (b) Terminal 1 and frame
- (2) Main contacts open
  - (a) Terminal 1 and terminal 2

10. Measure the insulation resistance between the following points, using a 250-V. insulation resistance tester. A reading of at least 50,000 ohm. should be obtained in each test.

- (1) Main contacts closed
  - (a) Terminal 7 and terminal 8
  - (b) Terminal 9 and terminal 10
- (2) Main contacts open
  - (a) Terminal 5 and terminals 7 and 9
  - (b) Terminal 7 and terminal 9
  - (c) Frame and terminals 5, 7 and 9

**Note . . .**

*The value of insulation resistance given in paras. 9 and 10 applies to switches being tested under normal workshop conditions. Due allowance should be made for the climatic conditions of the locality and those of the aircraft servicing area or dispersal point where the tests are being applied. In particularly damp climates, the readings obtained may be low enough to give apparently sufficient reason for rejection and, in these instances, discretion should be exercised.*

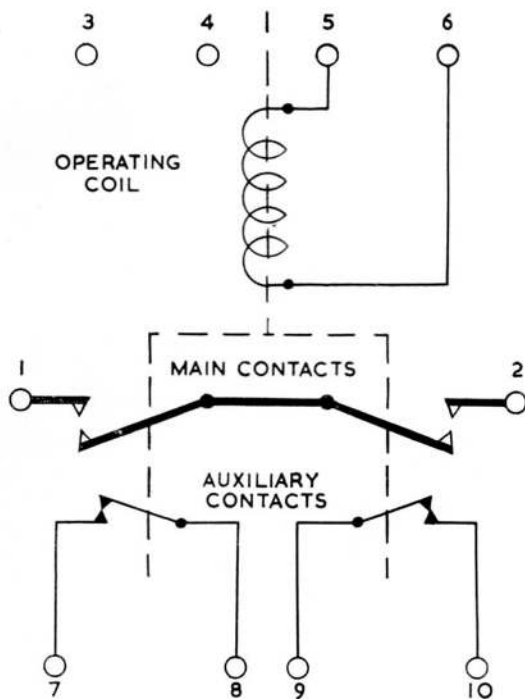

Fig. 2. Diagram of internal connections

**RESTRICTED**

This file was downloaded  
from the RTFM Library.

Link: [www.scottbouch.com/rtfm](http://www.scottbouch.com/rtfm)

Please see site for usage terms,  
and more aircraft documents.

