

Chapter 8

SWITCH, MAGNETIC, TYPE 5A, No. 1 (ROTAX D8701)

LIST OF CONTENTS

	Para.		Para.
Introduction	1	Inspection	4
Description	2	Operational test	7
Servicing	3		

LIST OF ILLUSTRATIONS

	Fig.
Type 5A, No. 1, magnetic switch	1
Diagram of connections	2

LEADING PARTICULARS

Switch, magnetic, Type 5A, No. 1	Stores Ref. 5CW/4382
Height	3.2 in.
Weight	2 lb.
Current rating	
Main contacts	5 to 15 amp.
Shunt field contacts	2.5 amp.
Auxiliary contacts	2.5 amp. 29 volts
Voltage	
Main and shunt field contacts	112V d.c.
Operating coil	29V d.c.
Coil resistance at 20 deg. C	22.5 to 27.5 ohm.
Temperature range	+ 40 deg. C to - 70 deg. C

Introduction

1. This switch, in common with others in the D8700 series, is designed for use in 112-volt d.c. installations where a double-pole reversing contactor is required for short rated duties, e.g., to reverse the direction of rotation of an actuator motor.

DESCRIPTION

2. The Type 5A switch (*fig. 1*) is identical to that described in A.P.4343, Vol. 1, Sect. 11, Chap. 14. Its auxiliary contacts (terminals 1, 2, 3 and 4) are normally open as indicated in *fig. 2*.

SERVICING

3. Assuming that the unit has been correctly installed and operated, servicing required will be restricted to a visual inspection; if the unit is functioning satisfactorily, it should be assumed to be serviceable for continued use.

Inspection

4. Remove the covers and inspect the contact surfaces for signs of excessive pitting due to arcing. The unit must be removed from service and a new one fitted if the degree of pitting warrants it.

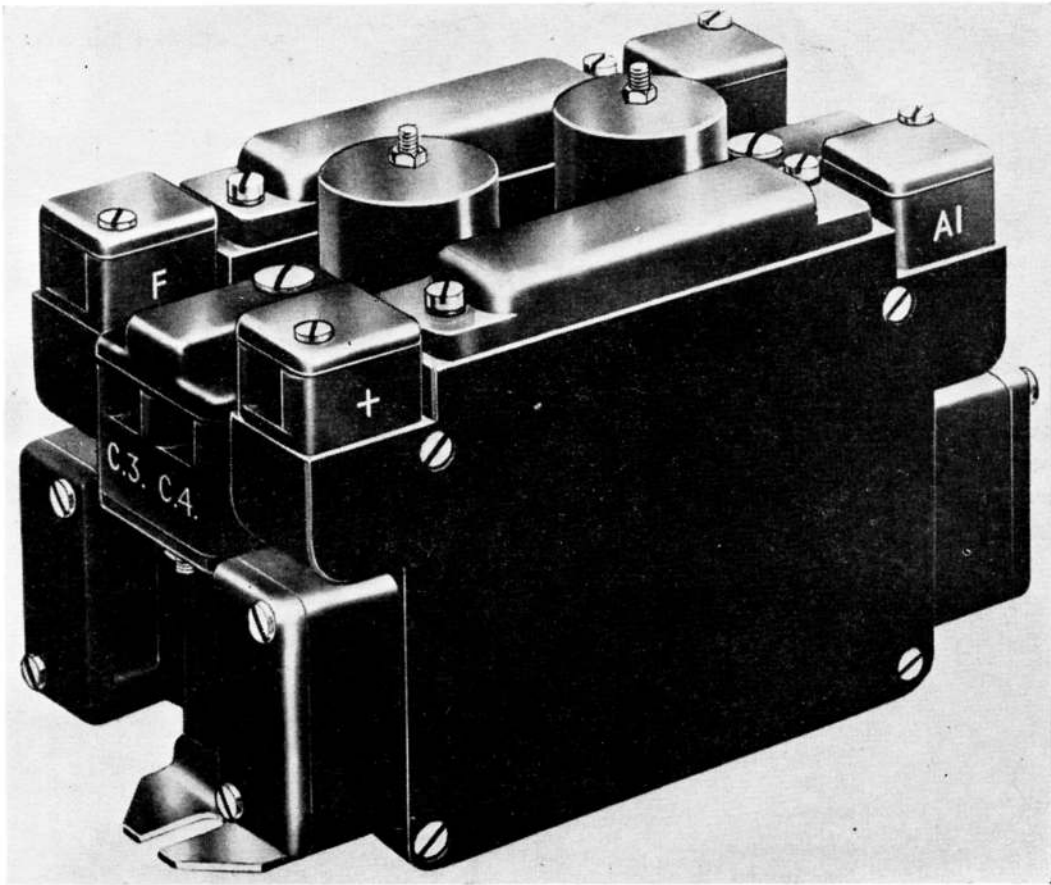

Fig. 1. Type 5A, No. 1, magnetic switch

5. Inspect all the terminal points and ensure that the cables are securely connected and show no signs of damage due to vibration.

6. Inspect the moulding and casting for signs of physical damage or distortion and ensure that the mounting bolts are securely locked.

Operational test

7. After installing the unit in the aircraft, a test must be carried out to ensure that it functions correctly. The equipment controlled by the unit should be operated to ensure that a complete cycle of operations is not restricted and that the current consumption is within the stated limits.

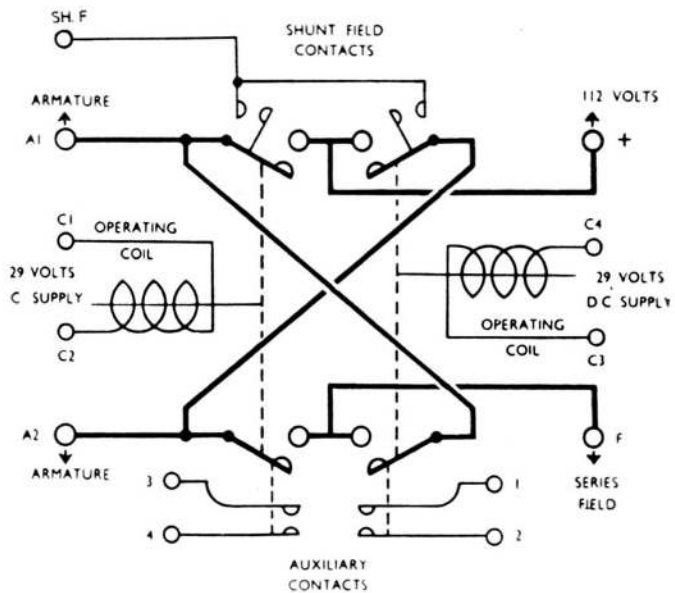

Fig. 2. Diagram of connections

RESTRICTED

This file was downloaded
from the RTFM Library.

Link: www.scottbouch.com/rtfm

Please see site for usage terms,
and more aircraft documents.

