

Chapter I

PLESSEY WIRING SYSTEM

LIST OF CONTENTS

	Para.		Para.
Introduction... ..	1	Ferrule plate assembly	24
Description		Ferrule for plastic tubing	25
Standard plugs	3	Conduit ferrule, Type H	26
Single plugs (fixed pins)... ..	4	Plug shroud	27
Single plugs (loose pins)... ..	5	Plug strainer	28
Single plugs (climatic-proof and flame-proof)	6	Crimping	29
Bulkhead plug (climatic-proof)	8	Junction boxes	30
Bulkhead plug (pressure-proof)... ..	9	Connecting the plug to the socket	31
Standard sockets	10	Terminal blocks	32
Socket (climatic-proof)	11	Quick release fuse blocks	37
Socket (vibration-proof)	12	Other fittings	39
Quick release connector	13	Routing charts	41
Special purpose connectors	14	Coding system	44
Heavy-duty pressure-proof bulkhead connector	16	Servicing	50
Flexible conduit assemblies	17	Renewing cables	51
Ferrules	21		
Cut ferrule (round and square base)	22		
Inner and outer ferrules	23		

LIST OF ILLUSTRATIONS

	Fig.		Fig.
Single plug (fixed pins)	1	Exploded socket (vibration-proof)	11
Single plug (loose pins)	2	Exploded plug (climatic-proof)	12
Single plug (climatic-proof)	3	Typical junction box	13
Bulkhead plug (climatic-proof)	4	Use of strap wrench	14
Bulkhead plug (pressure-proof)	5	Quick release terminal block	15
Plug and socket (climatic-proof)	6	Standard terminal block	16
Heavy-duty pressure-proof bulkhead connector	7	Quick release fuse block	17
Cut ferrule used with braided cable	8	Quick release fuse blocks	18
Ferrules	9	Socket ejector	19
Exploded socket (climatic-proof)	10	Preparation of the ends of screened cable	20

Introduction

1. In the Plessey wiring system the various cable runs associated with each unit are combined into cable assemblies which terminate at each end in a multiple plug or socket connected to a mating plug or socket on the unit. Plugs, which always contain male pins, are fixed items in that they are usually rigidly connected to junction boxes or bulkheads,

etc. (with the exception of the instance mentioned in para. 27), whereas sockets, which contain female inserts, are attached to the free cable assemblies. The disposition of the plug pins and socket inserts renders impossible mis-mating of the plug and socket. This technique results in a wiring system which is easily installed, permits rapid removal of the unit for bench servicing, and

provides ready accessibility for fault finding. The difficulty of tracing complicated circuits is greatly facilitated by the use of junction boxes, which provide convenient breaking points for cable entries, and a concise method of circuit recognition in which every service is coded, and every terminal, pin, socket, and cable, is completely designated.

2. The following paragraphs describe representative plugs and sockets of various types, together with their accessories, and detail the methods employed for connecting and servicing the items concerned. Mk. 4 miniature plugs and sockets are covered in a separate chapter.

DESCRIPTION

Standard plugs

3. Standard plugs are supplied with pin combinations ranging from 1 to 27 pins, covering current ratings from 7 to 64 amp. The pins are made from brass and are silver plated, whilst the metal bodies, depending upon installational requirements, are made of aluminium or steel (flame-proof). Standard plugs are divided into the following groups.

Single plugs (fixed pins)

4. In this type of plug (*fig. 1*) the pins are set in a moulding and are not removable. The moulding, and the aluminium plug shell which shrouds the pins and is internally threaded to receive the socket, are retained by four 6 B.A. nuts and bolts. The pins are shaped at one end to form solder buckets into which the cable ends are soldered. This range of plugs is now obsolete and will only be found where it has not been possible to replace them with loose pin plugs.

Single plugs (loose pins)

5. Two identical mouldings (*fig. 2*) are used in this plug to position the pins which are otherwise free. As in the previous type, one end of each pin forms a solder bucket, and a plug shell completes the assembly which is retained by four 6 B.A. nuts and bolts. The range is obsolescent and is being replaced by the climatic and flame-proof ranges described in the next paragraph.

Single plugs (climatic-proof and flame-proof)

6. Climatic-proof plugs are interchangeable with the loose pin type described above, and have been developed for use in exposed conditions where resistance to the ingress of oil, water, and the effects of high humidity, is necessary.

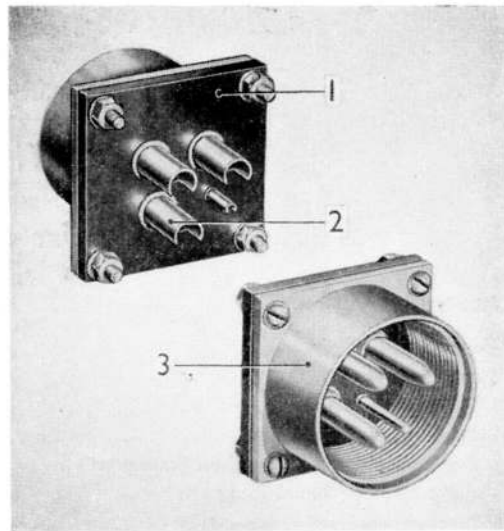

- 1 MOULDING
- 2 BUCKET ENDED PINS
- 3 PLUG SHELL

Fig. 1. Single plug (fixed pins)

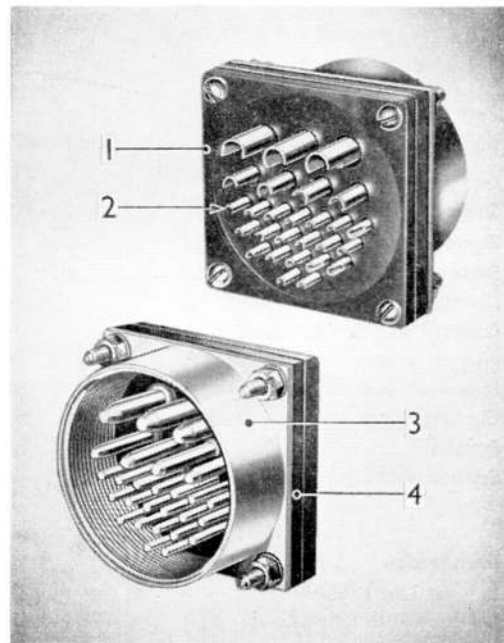

- 1 REAR MOULDING
- 2 BUCKET ENDED PINS
- 3 PLUG SHELL
- 4 FRONT MOULDING

Fig. 2. Single plug (loose pins)

RESTRICTED

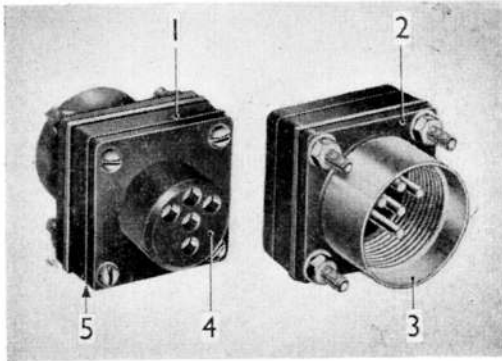

- 1 FRONT MOULDING
- 2 RUBBER GASKET
- 3 PLUG SHELL
- 4 REAR MOULDING
- 5 RUBBER GASKET

Fig. 3. Single plug (climatic-proof)

7. The pins of these plugs (*fig. 3*) are positioned in holes in the front moulding which prevent axial movement of the pins in a forward direction. A rear moulding completely shrouds the rear end of each pin and prevents axial movement rearwards. A plug shell, made of aluminium or steel—the latter material rendering the plug flame-proof—is mounted on the front moulding. A synthetic rubber gasket is located between the front and rear moulding, and between the front moulding and plug shell. A further gasket on the forward side of the plug shell

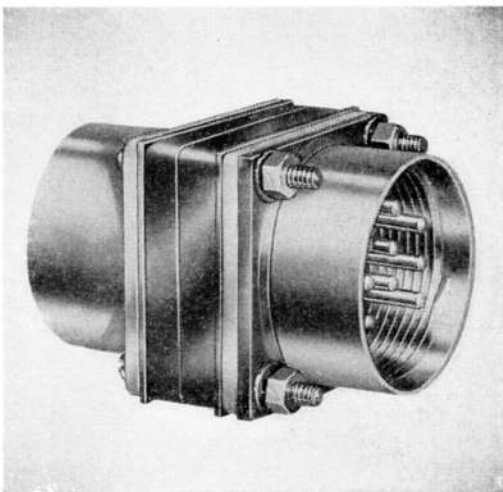

Fig. 4. Bulkhead plug (climatic-proof)

completes the assembly which is retained by four 6 B.A. nuts and bolts. Cable attachment to the pins is effected by crimping during the assembly operations.

Note . . .

The rear end of this type of plug is not water-proof since the plug should be mounted with the rear end inside the unit. The plug generally is not water-proof until it has been mated to its socket.

Bulkhead plug (climatic-proof)

8. The bulkhead plug is used to provide a convenient breakdown point from either side of a bulkhead or panel, etc. The bulkhead pins (*fig. 4*) are located between two mouldings. A moulding gasket and plug shell are positioned on each moulding, and a plug shell gasket is mounted on one shell. The assembly is retained by four 6 B.A. nuts and bolts. As with the single plug (climatic-proof), the bulkhead plug is not water-proof until it has been mated to its socket.

Bulkhead plug (pressure-proof)

9. Designed for use on pressurized equipment, this plug will withstand a differential pressure of 15 lb. per sq. in. The pins (*fig. 5*) are located between two mouldings which during assembly are faced with Bostik to seal the pins. A plug shell with a wide circular flange is located on one moulding, a gasket being interposed between the two mating surfaces. A standard plug shell fits on the remaining moulding, and a plug cover, located over the shell, is drilled to receive the eight studs attached to the flange of the pressure-proof plug shell. A further mounting gasket on the plug shell completes the assembly which is mounted on the bulkhead as shown in the illustration. This plug is supplied completely sealed and assembled, and only requires the nuts and washers to be removed before fitting to the aircraft.

Standard sockets

10. There are two types of standard sockets in use; the climatic and flame-proof type, and the vibration-proof type for use forward of the engine bulkhead.

Socket (climatic-proof)

11. The socket inserts (*fig. 6*) are positioned in stepped holes in a rear moulding. A tag is pressed out on each insert which abuts the step in the hole, thereby preventing the insert moving back. A socket moulding, located over the inserts at their forward end, both

(A.L.67, June 56)

supports the inserts and prevents forward movement. The two mouldings, preceded by an insulating washer, are located in a socket shell and retained in position by an insulating sleeve and circlip. The socket shell is screwed at its forward end for attachment to the plug shell of the relevant plug, the resulting joint being made watertight by a sealing gasket on the flange of the socket shell. The threads at the rear end of the shell accommodate the coupling nut which retains the socket ferrule gasket, and ferrule, of the cable assembly. A short thimble fits over each socket insert to permit cable attachment by crimping. A feature of this socket is that the individual inserts can be attached to the cable assembly and then inserted into the socket assembly where they automatically lock themselves in position. This is made possible by the fact that each insert can be inserted into the rear moulding until the tag springs into the stepped hole, as a result of which the insert cannot be withdrawn.

Socket (vibration-proof)

12. The difference between this and the preceding type socket is in the shape and method of

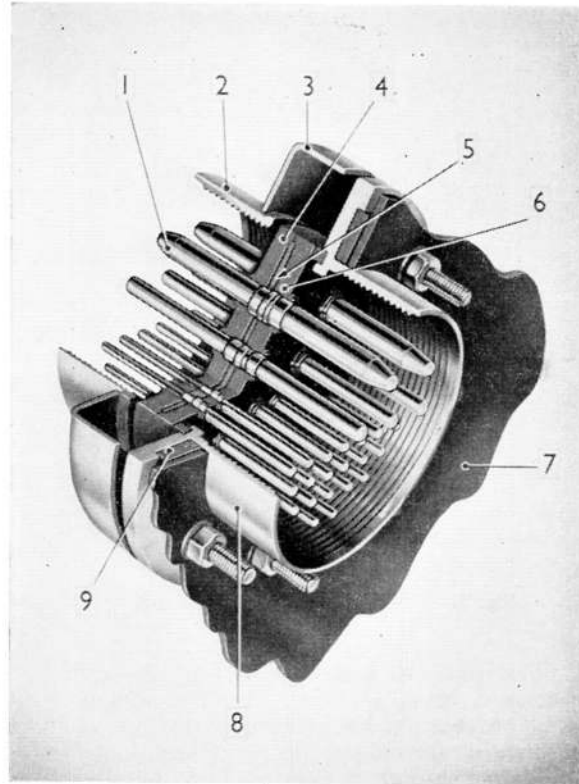

- | | | | |
|---|---------------------|---|----------------------|
| 1 | PLUG PINS | 6 | MOULDING |
| 2 | STANDARD PLUG SHELL | 7 | BULKHEAD |
| 3 | PLUG COVER | 8 | PLUG SHELL (SPECIAL) |
| 4 | MOULDING | 9 | MOUNTING GASKET |
| 5 | SEALING COMPOUND | | |

Fig. 5. Bulkhead plug (pressure-proof)

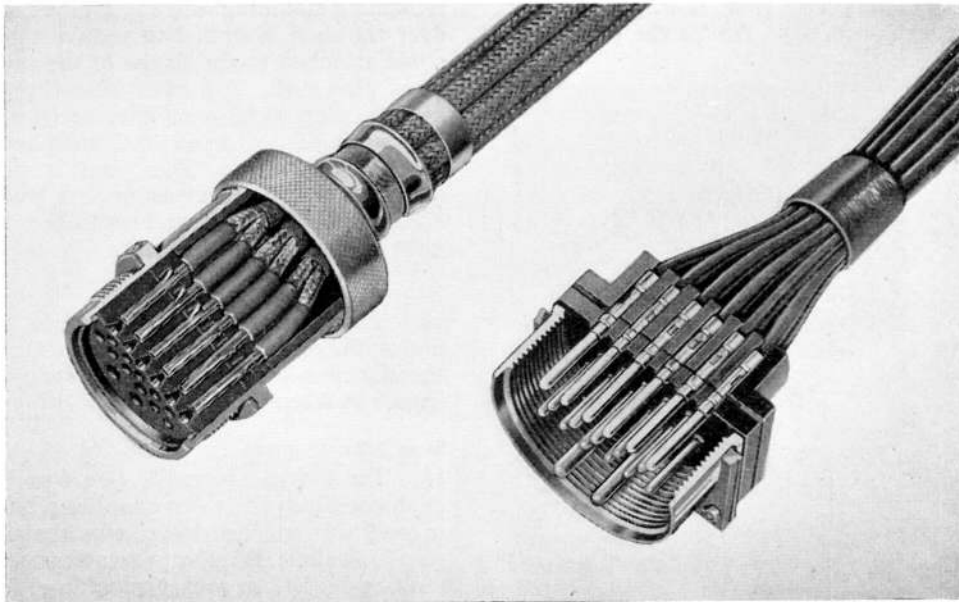

Fig. 6. Plug and socket (climatic-proof)

RESTRICTED

location of the socket inserts. The inserts (*fig. 11*) are solid turned and are appreciably reduced in diameter at one point. The inserts are positioned in a socket moulding and located axially by a slotted comb moulding, the slots fitting about the reduced diameter of the inserts. Cable attachment is by crimping and the remaining assembly details are the same as for the previous type. Note, however, that with this socket the inserts cannot be fitted to the assembled socket in the manner of the preceding type.

Quick release connector

13. A quick release connector is often fitted to mobile equipment to effect very rapid electrical connection. The plug and socket are standard except for the method of connection. The socket shell, instead of being threaded, has an external circumferential groove machined on it, whilst the plug shell is provided with four steel balls loaded by a rubber band. When the plug and socket are engaged, the four balls locate in the socket shell groove and retain the two assemblies. They may be separated simply by pulling away the socket. When not in use the plug pins are covered by a spring loaded cap.

Special purpose connectors

14. A variety of connectors have been specially designed to suit particular installation requirements. Such connectors will be met with more or less infrequently, and the following observations will serve as a guide to their construction.

15. Whilst variations in body shape, number and sizes of sealing gaskets, insulating washers and sleeves will occur, the pin and socket arrangement will generally be standard, i.e., solder bucket joint or crimping, fixed or loose pins, and self locking or vibration-proof inserts. These standard forms have already been discussed in the previous paragraphs.

Heavy-duty pressure-proof bulkhead connector

16. This connector, illustrated in *fig. 7*, is for use at pressure cabin bulkheads where heavy-duty leads require to be broken, and is fully pressure-proof to 15 lb. per sq. in. The type illustrated will accommodate two 200 amp. cables and one 19-amp. cable. These cables may have crimped or soldered lugs, the 19-amp. cable lug being of a circular ferrule type which plugs into the socket mounted on the terminal stud.

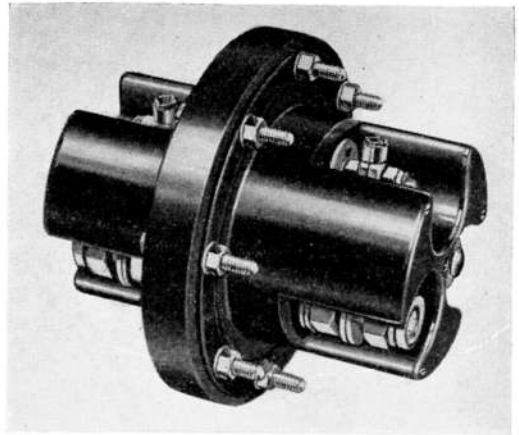

Fig. 7. Heavy-duty pressure-proof bulkhead connector

Flexible conduit assemblies

17. Two types of conduit and cable coverings may be found in the assemblies. These are:—

(1) The screened system, consisting of lengths of aluminium tubing protected and screened by aluminium alloy or tinned copper braiding. This type of conduit is now used only in those sections of the wiring system where electrical screening is essential, or additional mechanical protection is required. Occasionally braided cable may also be used.

(2) The unscreened system; in all parts of the wiring where electrical screening is not essential, polyvinyl chloride—a plastic conduit—replaces the metal conduit.

18. Coupling nuts are assembled on these lengths, and the ends, in the case of screened conduit, are finished by means of a swaged ferrule. The ends of unscreened conduit are fixed by one of the attachments described in para. 24 to 26. The cables carried within the conduit may terminate in a multiple socket as described in para. 11 to 13, in a plug and plug shroud as described in para. 27, or they may emerge as tails from the conduit through a ferrule and be directly connected to the various pieces of equipment.

19. When the cable terminates in a multiple socket the connections to the socket pins are crimped, or soldered, and covered with a rubber sleeve which serves to protect the joint. Each wire bears a designating marker

(A.L.67, June 56)

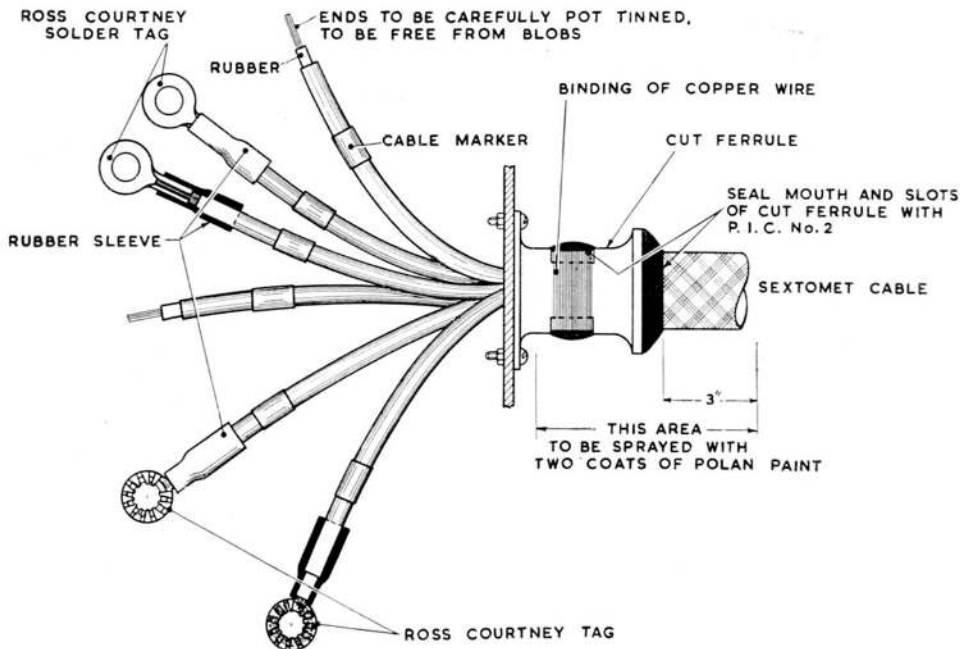

Fig. 8. Cut ferrule used with braided cable

corresponding to the socket pin to which it is wired. When the socket assembly is completed, it is attached to the conduit through a suitable ferrule by means of a coupling nut.

20. When the shortness of the run does not warrant the use of multiple plugs and sockets on junction boxes, the wires emerge through a cut ferrule where they are anchored by binding. Waxed thread is used on unscreened cables, and bare tinned copper wire in the case of metal braided cable. In the latter case the wire is soldered to the braiding and sealed with Bostik 771 (fig. 8). Note that if a Helvin sleeve is fitted over the ferrule, the application of Bostik may be dispensed with. The whole ferrule area is treated with Polan paint (Stores Ref. 33B/636) to render it waterproof and, finally, if the tails are of screened cable, two coats of Polan paint are sprayed over a minimum distance of 3 in. beyond the end of the ferrule, avoiding the area covered by the coupling nut. In naval aircraft, insulation varnish (Stores Ref. 33B/938) is to be used for this purpose instead of Polan paint. Alternatively a single cable may emerge through a sleeved Helsyn grommet. This method is also used where wires are brought out of the conduit assembly for direct connection to the equipment which they serve, as in fig. 8.

Ferrules

21. Various shaped ferrules are used to reduce the mechanical load on the connections and, where necessary, to make water-proof the various type cable assemblies at their point of entry into sockets and junction boxes etc.

Cut ferrule (round and square base)

22. A cut ferrule of the type shown in fig. 9 (1) may be used on a socket in conjunction with bunched cable assemblies, and a split sleeve. The cables are passed through the split sleeve and connected to the socket, after which the ferrule is located on the socket and retained by a coupling nut. The sleeve is then pulled up over the ferrule and bound with twine which is afterwards coated with shellac varnish. If braided cable is used, the method of entry is that described in para. 20. For direct entry into, for example, a junction box, a cut ferrule, having a square base (2, fig. 9) for mounting on the box, is used in a similar manner.

Inner and outer ferrules

23. For cable assemblies contained in plastic (P.V.C.) tubing, the method of attaching the tubing to the socket is through inner and outer ferrules (3, fig. 9). The outer ferrule is slid back over the tubing, whilst the inner

RESTRICTED

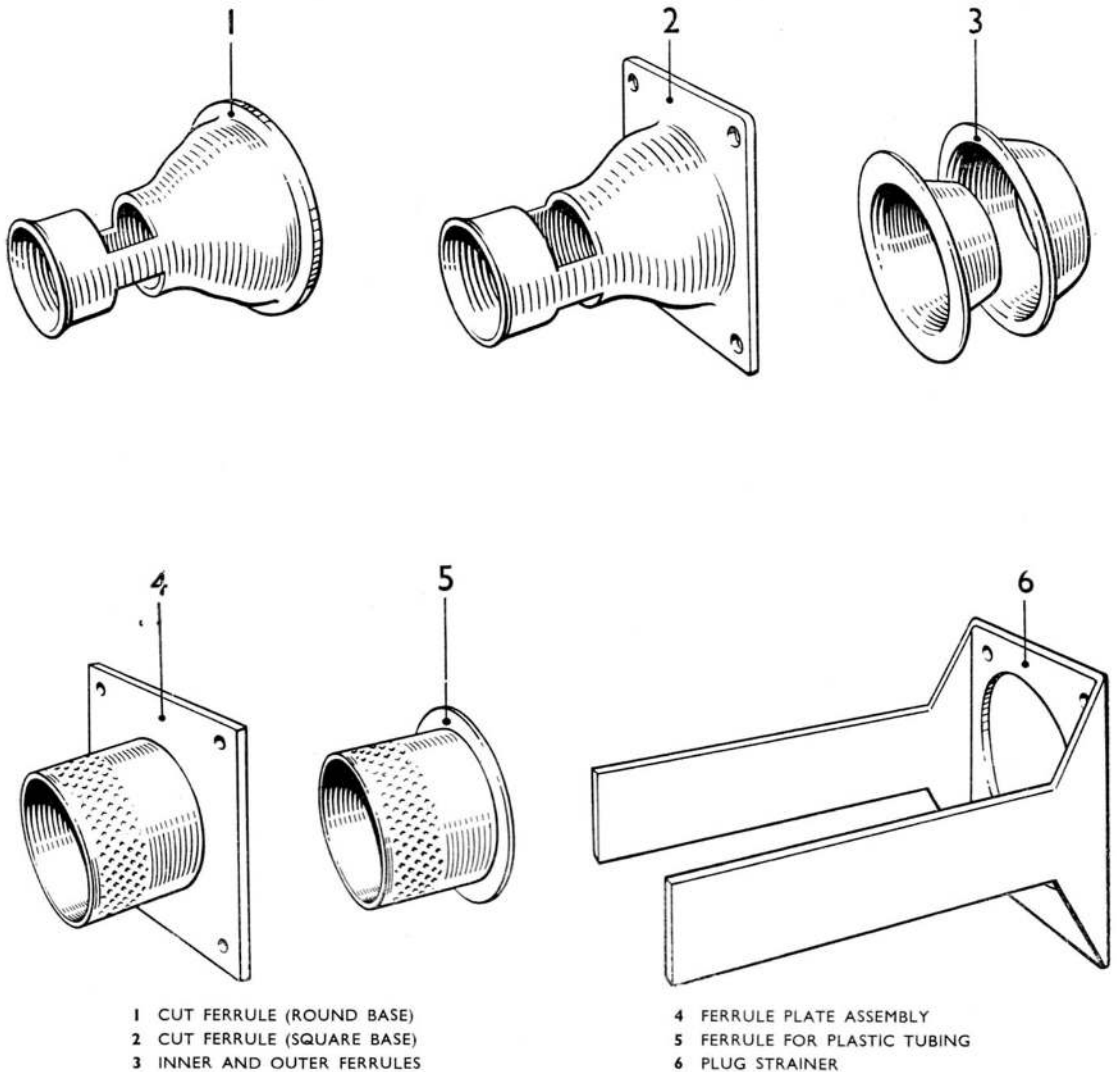

Fig. 9. Ferrules

ferrule is located in the end of the tubing. The two ferrules are then squeezed together and retained against the socket by the coupling nut.

Ferrule plate assembly

24. For direct cable entry into a junction box, a ferrule plate assembly (4, *fig. 9*), mounted on the box, is used. The cables pass through the ferrule plate into the box, whilst the end of plastic tubing passes over the collar of the plate and is retained by a pinched, or screwed, type clamp ring.

Ferrule for plastic tubing

25. This ferrule (5, *fig. 9*) is used in precisely the same way as the ferrule plate mentioned above, except that the flange of the ferrule is made circular for use on sockets. It thus provides an alternative to the inner and outer ferrules.

Conduit ferrule, Type H

26. This ferrule is swaged to the ends of flexible metal conduit and is flanged for retention by the socket coupling nut. The cables carried within the conduit are connected to the socket in the usual manner.

Plug shroud

27. A plug shroud and coupling nut is occasionally fitted to one side of the plug in conjunction with a Bakelite distance piece. This shroud is, in effect, one half of a socket shell. Any plug may thus be adapted to accommodate all the previously detailed socket ferrules, and be used on the free end of a cable assembly. Where a cable assembly, or conduit, passes directly into a junction box or through a panel, a plug shroud is often used to provide an attachment for the P.V.C. sheathing in conjunction with one of the circular ferrules detailed above.

Plug strainer

28. A plug strainer (6, *fig. 9*) is sometimes fitted to the rear of a plug. The two tags are bent down on to the cable, and the cable and tags are bound with twine to reduce the mechanical load on the cable to socket connections.

Crimping

29. Instructions for crimping plug pins, socket inserts, and quick-release tags on to the cable ends will be found in A.P.4343, Vol. 1, Sect. 12, Chap. 5. Special crimping tools are required, the hand crimping tool kit, No. 3 (Stores Ref. 5X/3186), which has a range of dies suitable for crimping 4 amp., 7 amp., and 19 amp. plug pins, socket inserts and tags, and the heavy duty tool kit (Stores Ref. 5X/6462), which includes dies for 37 amp. and 64 amp. plugs and sockets.

Junction boxes

30. The junction boxes used in this equipment have outlets fitted with multiple plugs, as shown in *fig. 13*. All the outlets bear cable assembly reference numbers (as F4, F15, etc.) which correspond to the appropriate cable run. Wiring within the box is soldered or crimped to the ends of the plug pins, the opposite ends being connected to quick release terminal tags or other equipment within the box. The wires are designated with the circuit reference, and joints, with the exception of crimped plug pins, are protected by rubber sleeves which cover the connection and extend over both the cable and the joint. For ease in service, terminals are provided for all leads which may be commoned or require splitting for fault location. All terminals are marked with their circuit designation. It will be observed from the illustration that various type plugs may be fitted from the inside or outside of the box, depending upon installation requirements. Fixed pin and climatic-proof plugs are fitted to this box; single cables

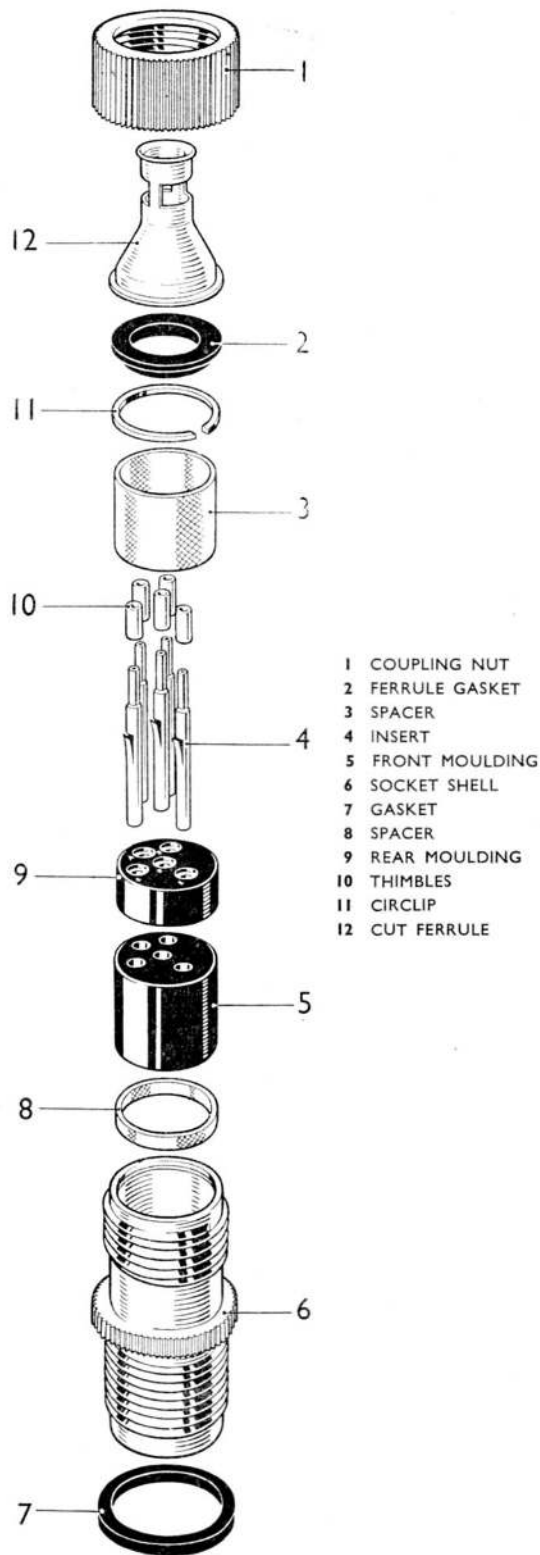
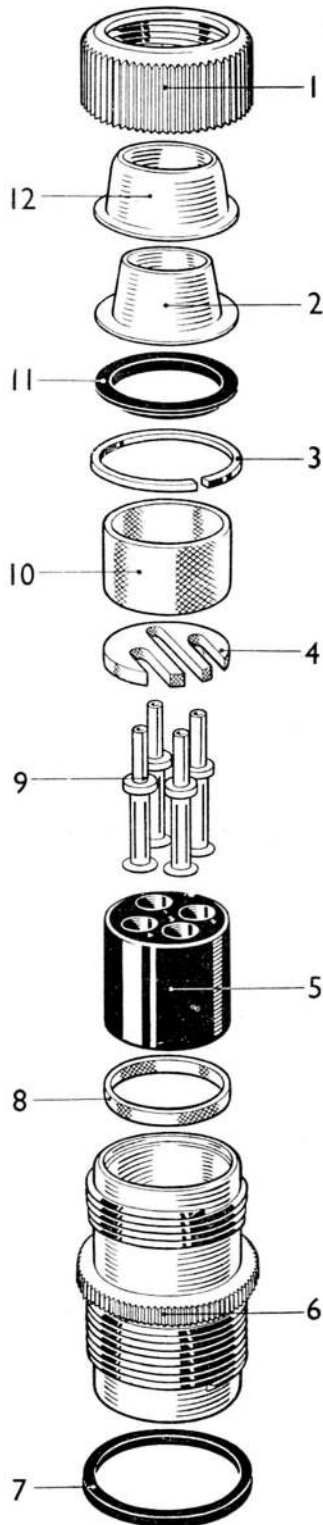

Fig. 10. Exploded socket (climatic-proof)

RESTRICTED

**KEY TO FIG. 11**

- 1 COUPLING NUT
- 2 INNER FERRULE
- 3 CIRCLIP
- 4 SLOTTED COMB MOULDING
- 5 MOULDING
- 6 SOCKET SHELL
- 7 GASKET
- 8 SPACER
- 9 INSERTS
- 10 SPACER
- 11 FERRULE GASKET
- 12 OUTER FERRULE

are fed through Helsyn grommets, whilst groups of multi-core cable are accommodated in ferrule plate assemblies. Fasteners for the box lid are of the conventional Oddie type which can be fastened by a 90 deg. turn of the fastener head in the lid.

Connecting the plug to the socket

31. With the exception of the quick release type of connector which is connected simply by pushing the plug into the socket, all other types should be connected as follows, it being assumed that the plug is in every case rigidly mounted on some piece of equipment.

- (1) Slacken the socket coupling nut, so that the socket shell can be rotated without winding up the cable assembly.
- (2) Line up the holes in the socket with the plug pins and screw the socket shell into the plug shell. Tighten the socket by applying a strap wrench to the knurled flange of the socket shell as shown in fig. 14.
- (3) Screw up the coupling nut and tighten with a strap wrench.

To uncouple the plug and socket **FIRST** slacken the coupling nut, then unscrew the socket shell and remove the socket.

Terminal blocks

32. Terminal blocks of the quick release type shown in fig. 15 have largely replaced the standard terminal block shown in fig. 16, and are now used extensively in junction boxes.

33. Beneath the head of the terminal screw is located a clamp channel, a spring, and a terminal coding plate. The screw head bears against the clamp channel which in turn presses down upon the terminal coding plate beneath which is the quick release tag of the cable. The tag is cranked to fit similar cranks

Fig. 11. Exploded socket (vibration-proof)

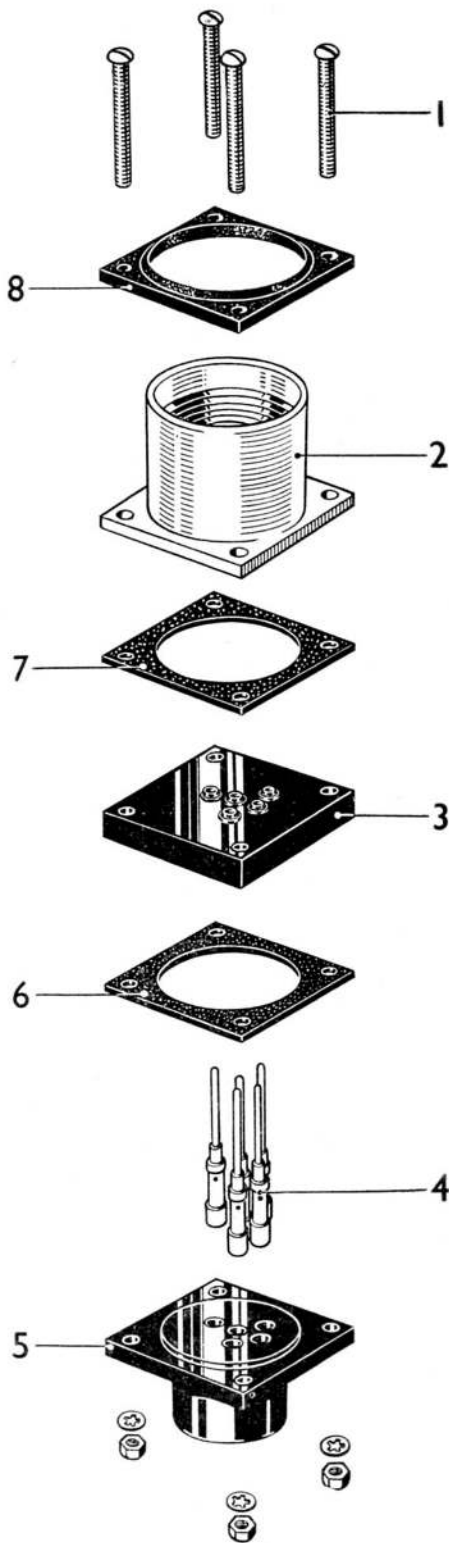

Fig. 12. Exploded plug (climatic-proof)

KEY TO FIG. 12

- 1 ASSEMBLY SCREWS
- 2 PLUG SHELL
- 3 FRONT MOULDING
- 4 PLUG PINS
- 5 REAR MOULDING
- 6 GASKET
- 7 GASKET
- 8 MOUNTING GASKET

in the coding plate and the screw base, which results in a very strong mechanical connection. The tag can be connected or removed by a turn of the screw, which is rendered vibration-proof by the spring. The terminal block may have 2, 3, 5, 10 or 20 terminals or "ways," the 20-way type being a double-sided block of 10.

34. Also used in connection with these terminal blocks are commoning links for permanently connecting from two to ten adjacent terminals. A transverse link is used to connect opposing terminals on the double-sided or 20-way block.

35. The terminal coding plate carries an insulated metal plate covered by a transparent P.V.C. sleeve, the plate being coded for circuit identification. In some instances a transparent cover is fitted over the block, for which purpose fixing pillars are used in place of the screws normally required to hold the block in position.

36. A quick release tag may be attached to the cable by soldering or crimping. In the latter case a thimble must first be placed over the tag as in the case of the socket inserts described in para. 11.

Quick release fuse blocks

37. Whilst the standard fuse block, which is shown in fig. 18 (3) and requires no description is still in use, it is being superseded by a quick release type shown in fig. 17.

38. The method of connecting the terminals to the cables is by quick release tags, the principle being similar to that described in para. 33. In addition the fuses may be carried in fuse extractors (1, fig. 18) to facilitate insertion and removal of the fuses from the holder. Alternatively the fuse extractors may be omitted and the fuses covered by a transparent cover as shown in fig. 18 (2), the sides of the block being suitably heightened to permit this. The various arrangements

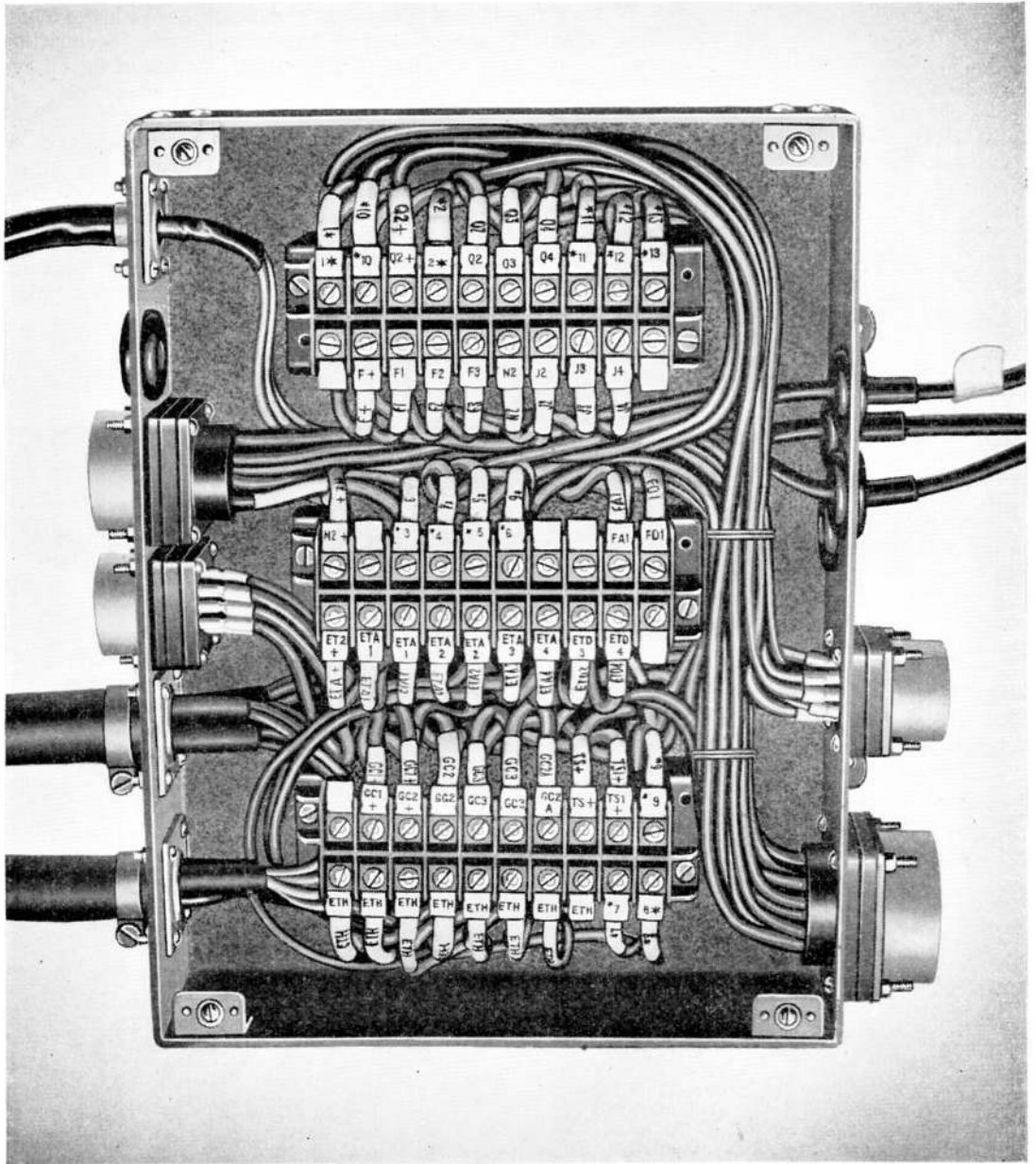

Fig. 13. Typical junction box

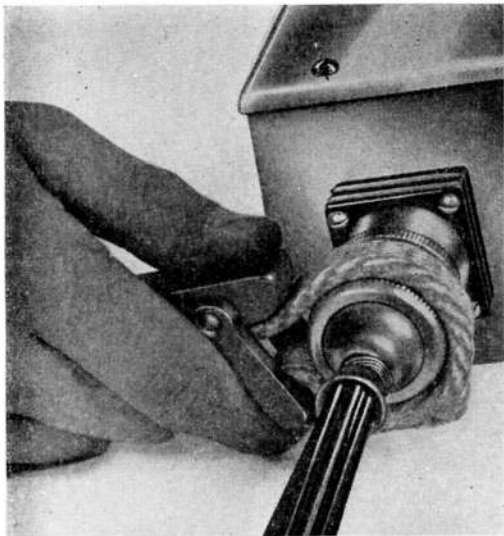

Fig. 14. Use of strap wrench

adopted will depend on design and installation requirements. As with the terminal block, commoning links are used to connect consecutive terminals. In practice a 4-way commoning link is supplied which may be cut to length as required.

Other fittings

39. Where lack of space would otherwise necessitate the bending of screened conduit

in a sharp curve, a 45 deg. or 90 deg. elbow must be employed. When little pull or vibration is likely to take place and there is only a minimum of space available, the tails may emerge from a ferrule, a rubber sleeve being fitted over the conduit. With the more general use of unscreened cable, permitting a smaller bending radius, the use of the elbow fitting is gradually becoming obsolete.

40. A conduit assembly may also have a socket at one end and a plug at the other (*para. 18 and 27*). In this case, when disconnection is required on one side only, the plug is used at the section break. This type of assembly may also be used where lack of space, or weight, rules out the use of a bulk-head plug.

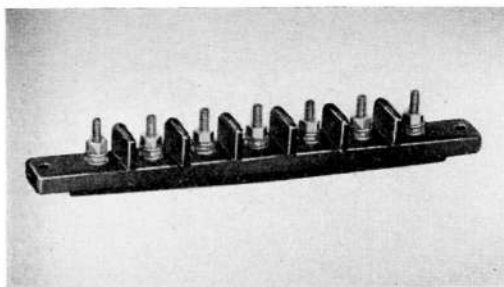

Fig. 16. Standard terminal block

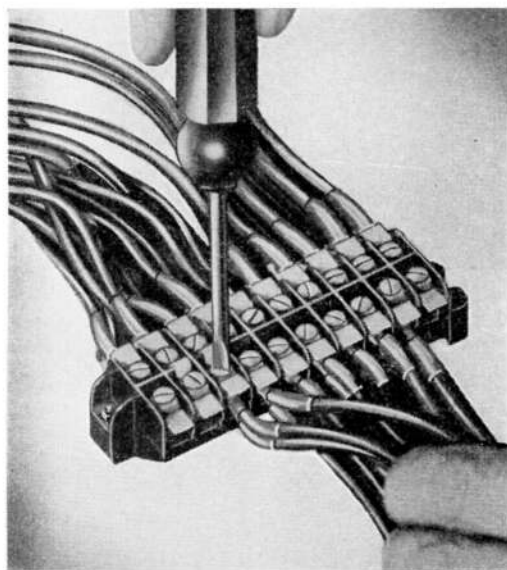

Fig. 15. Quick release terminal block

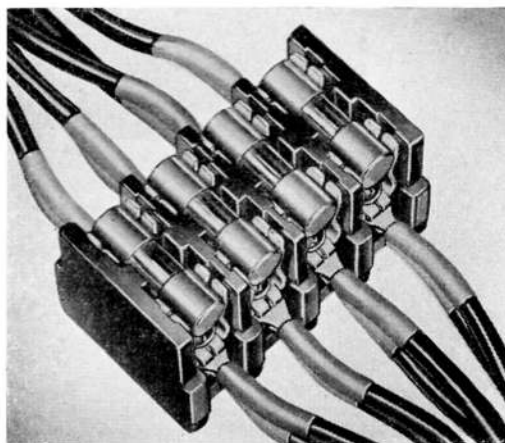
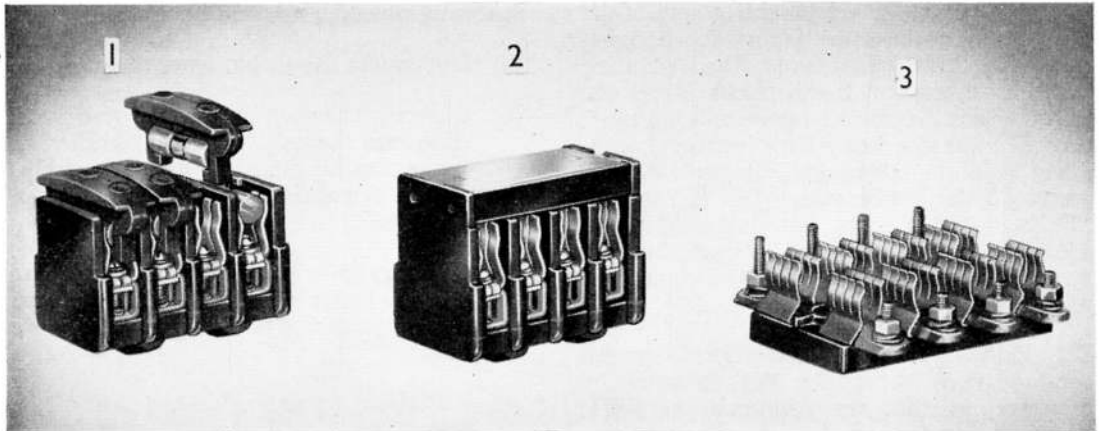

Fig. 17. Quick release fuse block



1 FUSE BLOCK WITH FUSE EXTRACTORS 2 FUSE BLOCK WITH TRANSPARENT WINDOW
3 STANDARD FUSE BLOCK

Fig. 18. Quick release fuse blocks

Routing charts

41. At first sight a routing chart, which is an essential part of the fault-finding equipment, may appear complicated and difficult to comprehend, but closer inspection will prove that it simplifies the task of tracing the circuit very considerably. The following description of the chart, and the conventions used will therefore be found of some assistance if read in conjunction with a routing chart given in one of the aircraft handbooks.

42. The object of the chart is to obtain a horizontal straight line diagram of the circuit with wide spacing in order to afford maximum legibility. The first column gives the service title and circuit reference used in the theoretical wiring diagram, and the electrical equipment on the particular services is shown in the various equipment columns. The space between these equipment columns is conveniently divided to carry the junction box (J.B.) numbers, and conduit references and pin numbers are given within the conduit column. It should be noted that where connection is made by means of a plug and socket to a particular junction box or piece of equipment, the joint is indicated by a dot on the line. Where, however, a cut ferrule or rubber grommet is employed, no dot is shown, connection being indicated solely by the terminal number in the column.

43. The type of cable employed is indicated by designations above the cable line, usually at the left-hand side of the cable run.

Coding system

44. The coding system provides for every wire to bear a letter and number for the purpose of easy identification. Reference to the theoretical wiring diagram or aircraft routing chart will show that each circuit incorporated is allocated a reference letter or letters, whilst individual wires comprising each circuit has a number as a suffix to the circuit letter. For example, if a circuit comprising a fuse, a switch and a lamp bears the letter "H" as circuit reference, the wire between the fuse and the switch will be "H1" and from the switch to the lamp will be "H2". The positive feed to the fuse and the negative to the lamp will bear the reference of the generator system from which the circuit is fed.

45. Similarly, the main feeds from batteries and generators will remain the main feeds throughout the aircraft, so that where essential loads are coded A, metered loads will be marked A1 and generator loads A2. If two generators are employed, the second one may be coded respectively B, B1, B2, etc., the appropriate designation + or - being added to the letter and number combination where necessary.

46. General service conduits situated in the fuselage are given the prefix F, being numbered F1, F2, F3, etc. Conduits located in the port wing are lettered with the prefix P, while those in the starboard wing use the prefix S. Compass cables carry the prefix C. Junction boxes are given the prefix JB, and conduits used for bomb fuzing and release systems are lettered with the designation of

(A.L.67, June 56)

the junction boxes which they serve, e.g., AB indicates a conduit connecting junction boxes "A" and "B". Where several conduits are used between the same points the designations AB2, AB3, etc. are used. The leads from junction boxes to bomb racks have the junction box letter and bomb rack number, thus A7 indicates rack 7 from junction box A. Since junction boxes are lettered with the prefix JB the combinations JB "A" and JB "B" are formed. The lettering used varies according to the make of aircraft, but the system of coding which has been given here may be accepted as a general guide.

47. Radio intercommunication system conduits bear the prefix WT followed by numbers, so that the combinations WT1, WT2, etc. are formed. Junction boxes in this system are prefixed with the letter W and lettered so that the form WA, WB, etc. is obtained. Bulkhead plugs are designated according to their identification letter followed by a number.

48. Where wires pass through conduits they are not given individual wire reference numbers but are coded with the letter or number of the socket pin to which they are attached, i.e. F1-A, etc.

49. Where, however, the wire is broken at a junction box by a terminal, the appropriate circuit code letter and number is used to identify this terminal and the particular wire in the box. Thus, if a certain cable in the navigation lamp circuit is marked H2, the same designation will appear on all terminals in the junction boxes through which it passes. Full information is given in the appropriate theoretical wiring diagram with regard to identification at the ends of the leads, and the correct marking off is usually obvious. The size of the wires for a particular service, and the core colour (where used) are sometimes indicated on the theoretical wiring diagram and always on the routing chart.

SERVICING

50. General information on the servicing of aircraft wiring systems is given in A.P.4343, Vol. 1, Sect. 12, Chap. 5. In addition, the following points should be noted.

Renewing cables

51. If it is necessary to renew a cable, the old cable, if contained in a conduit, may be used as a draw-wire for the new one, bearing in mind that the ends of the old wire must first be removed from any bunching sleeves which

are fitted. To minimize the work in connecting a new cable to a climatic-proof socket the following procedure should be adopted.

- (1) Disconnect the socket from the plug.
- (2) Unscrew the coupling nut (*fig. 6*) and slide back the nut, ferrule and washer, as far as possible along the cable assembly. If a cut ferrule is used, first cut away the binding.
- (3) Working from the front end, insert the socket ejector (*fig. 19*) in the relevant hole in the socket moulding, and eject the insert.
- (4) Pull the insert and cable-end clear of the socket.
- (5) Push the insert of the new cable, complete with marker, into the vacant hole in the comb moulding until the insert locks into position.
- (6) Re-assemble the socket and re-make the ferrule connection.

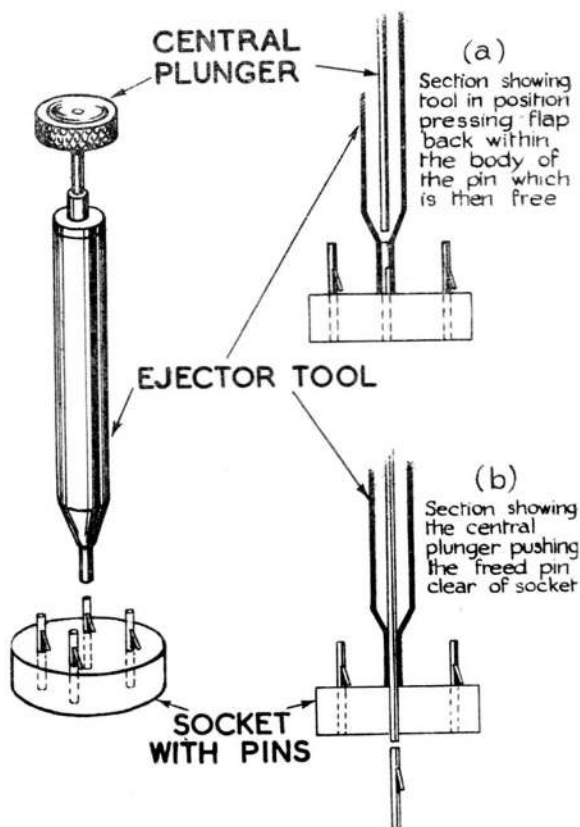

Fig. 19. Socket ejector

Note . . .

Ejector tools are available in the following sizes:—

Tool to fit pin size	Stores Ref.
7 amp. (SP)	5X/2236
7 amp.	5X/2237
19 amp.	5X/2238
37 amp.	5X/2239
64 amp.	5X/2240

52. To connect a new cable to a vibration-proof socket, proceed as in para. 51, sub-para.

(1) and (2), then remove the circlip and inner ferrule (fig. 14) and push up the moulding just sufficiently to permit the comb moulding to slide clear. Now remove the old cable insert from the socket moulding and fit the new one in its place. Refit the comb moulding and reassemble the socket.

53. When renewing a braided cable, the ends of the new cable should be prepared as shown in fig. 20 and then fed through a cut type ferrule. If necessary, the leads and ferrule should be weatherproofed by means of a length of P.V.C. conduit.

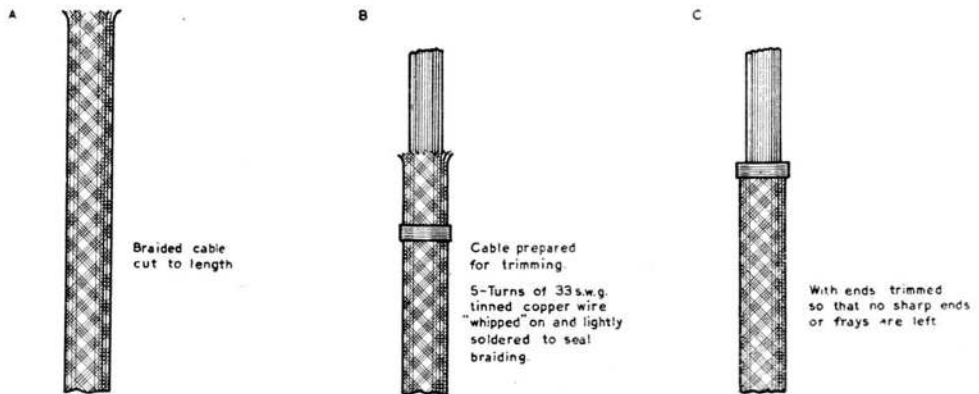

Fig. 20. Preparation of the ends of screened cable

This file was downloaded
from the RTFM Library.

Link: www.scottbouch.com/rtfm

Please see site for usage terms,
and more aircraft documents.

