

## Appendix 3

### FERRANTI TYPE A

#### LIST OF CONTENTS

	<i>Para.</i>		<i>Para.</i>
<i>Introduction</i> ... ..	1	<i>Servicing</i> ... ..	6
<i>Description</i> ... ..	2	<i>Testing</i> ... ..	8
<i>Operation</i> ... ..	4		

#### LIST OF ILLUSTRATIONS

	<i>Fig.</i>
<i>Suppressor unit type A</i> ... ..	1
<i>Internal view</i> ... ..	2
<i>Circuit diagram</i> ... ..	3

#### LEADING PARTICULARS

<b>Suppressor unit type A (Part No. 84/40200)...</b>	<b>Ref. No.</b>
<i>Voltage</i> ... ..	200V 3 phase a.c.
<i>Overall dimensions</i> ... ..	3.6 in × 3.9 in × 1.7 in
<i>Weight</i> ... ..	15 ozs

#### Introduction

1. The suppressor unit type A is designed to reduce transient high voltage pulses produced by the switching of d.c. loads, from appearing on the 3 phase a.c. supply lines and damaging equipment which may be connected to these lines.

#### DESCRIPTION

2. The unit consists of 24 diodes mounted on a silicon-bonded glass fibre moulding and three wire wound resistors, all the components are mounted within a metal box (fig. 1). The diodes are mounted on the moulding in sets of four and there are three compartments, with two sets in each (fig. 2). The four diodes in each set are wired in series and a resistor connects the two sets in opposition. The three compartments are connected in delta and the connections are taken to three terminals.

3. The moulded block is mounted on the metal baseplate of the unit and fitted with a removable cover. The three  $\frac{1}{4}$  in U.N.F.

terminals which are provided for the external connections, are housed in shrouded compartments at the side of the block and fitted with a removable cover.

#### OPERATION

4. Under normal operating conditions of 200 volts (r.m.s.) the circuit shown in fig. 3 will have no effect on the external circuit, as the matched sets of four diodes will not conduct. But if there is a high voltage pulse on any of the lines L1, L2 or L3 the diodes in that particular line will conduct, and short circuit voltages in excess of 430 volts, so as to reduce this high voltage to a safe value.

5. The two sets of diodes in each compartment are connected in opposition, to suppress both the positive and negative going pulses, and the resistors are connected between the two sets to limit the current. The diodes are connected in series in sets of four to cater for voltages between 420 and 440 volts.

**RESTRICTED**

### SERVICING

6. Remove the terminal cover and check the electrical connections for security of attachment, and signs of corrosion, deterioration or damage.

7. Remove the cover of the unit and check for signs of corrosion, deterioration or

damage, to either the diodes or resistors. If one of the diodes becomes unserviceable the complete set of four must be renewed.

### Testing

8. The unit should be tested in accordance with the procedure laid down in Appendix C.

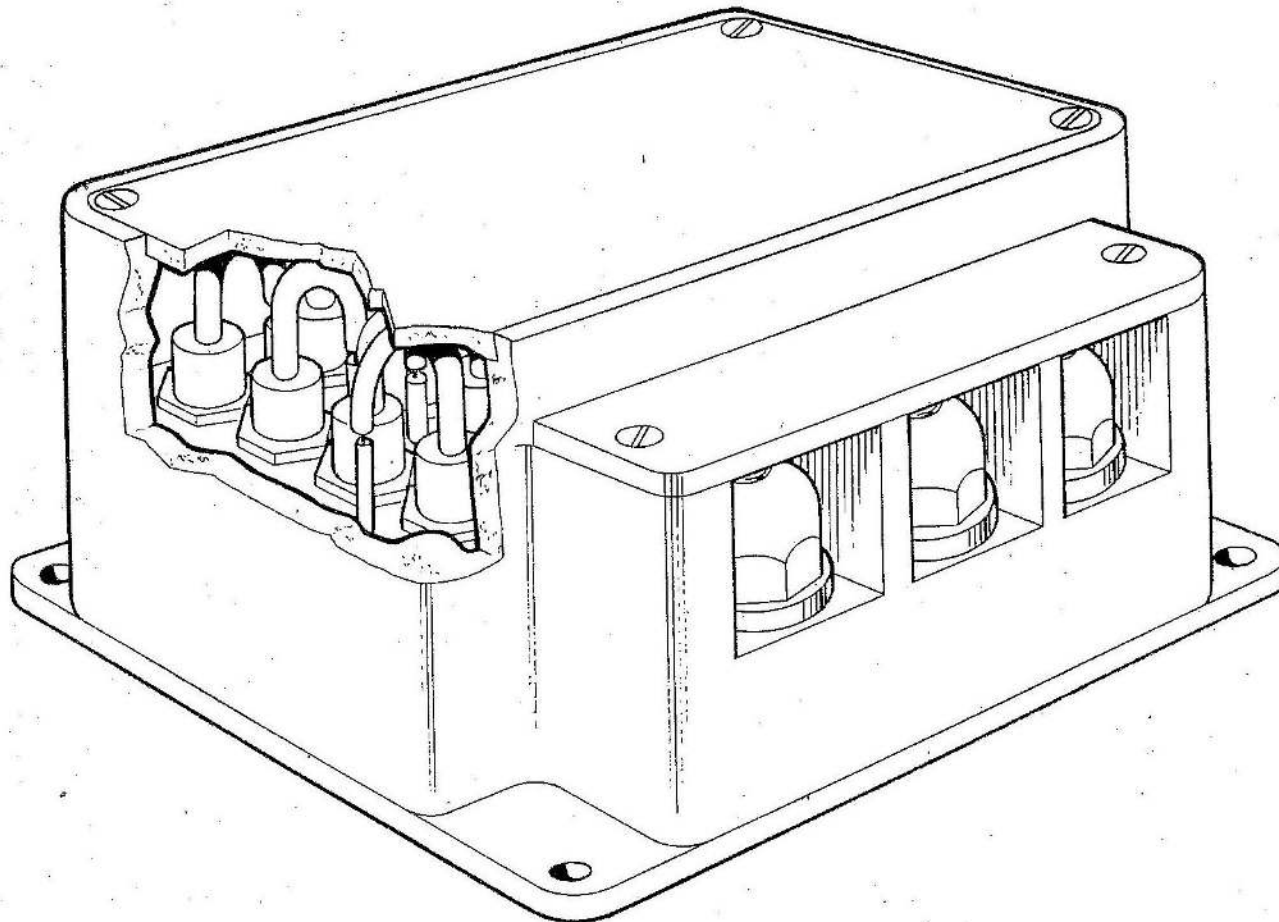

Fig. 1. Suppressor Unit type A

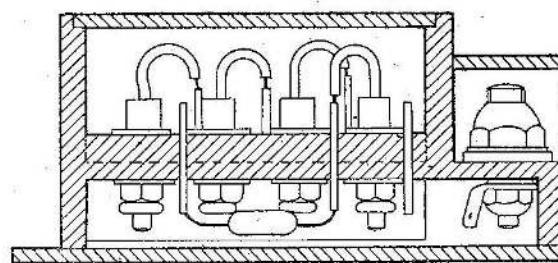

Fig. 2. Internal view

**RESTRICTED**

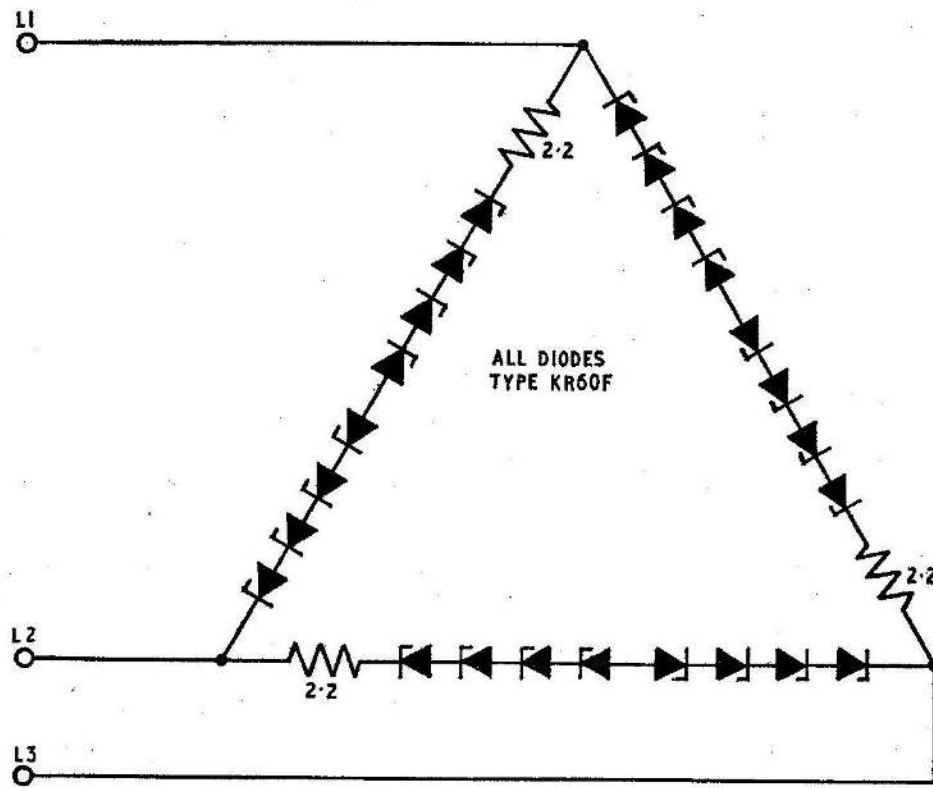

Fig. 3. Circuit diagram

**RESTRICTED**

## Appendix C

### STANDARD SERVICEABILITY TEST

### FOR

### FERRANTI SUPPRESSOR UNIT TYPE A

#### Introduction

1. The tests detailed in this appendix are to be applied to the unit before it is put into service, or at any time when its serviceability is suspect.

#### TEST EQUIPMENT

2. The following test equipment is required:—

- (1) Power Unit Variable Voltage CT397 (Ref. No. 6625-99-943-3268).
- (2) Multimeter Model 8SX (Ref. No. 6625-99-943-1524).
- (3) Switch, double pole changeover (Ref. No. 5CW/7748 or equivalent).
- (4) Power supply 200V, 400c.p.s. 3 phase.

#### TEST PROCEDURE

##### Functional tests

3. Connect the test equipment as shown in fig. 1 ensuring that the mains voltage tapping on the CT 397 transformer is in the correct position for the mains voltage being used. (Detailed information and operating instructions for the CT 397 are contained in BR 177 (27) ) and apply the following tests:—

- (1) Set S1 to position 1. Set multimeter to 50 $\mu$ A d.c. range. Set METER

switch on CT 397 to VOLTS and MAINS switch to ON.

(2) By means of the OUTPUT potentiometer, increase the output of the CT 397 to 200V.

(3) Check that the current through the diodes is less than 15 $\mu$ A (measured on multimeter).

(4) Set multimeter to 10mA d.c. range and slowly increase the output of the CT 397.

(5) Check that at an output voltage of between 430V and 480V the current through the diodes rises sharply.

(6) Reduce the output of the CT 397 to 200V.

(7) Set switch S1 to position 2 and repeat tests (3) to (5) above.

(8) Set MAINS switch to OFF.

(9) Repeat tests (1) to (8) with test equipment connected to terminals L1-L3 and L2-L3 of the Suppressor Unit in turn.

(10) On satisfactory completion of the above tests, disconnect and remove the test equipment. Connect Suppressor Unit to a 200V, 400 c.p.s. 3 phase supply and measure the current in each line. Check that the current is not greater than 100mA.

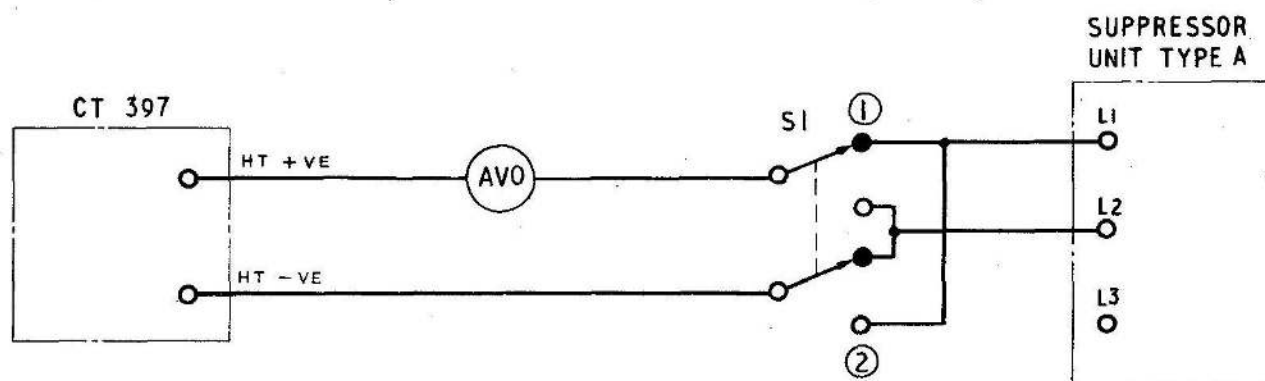

Fig. 1 Test Circuit

**RESTRICTED**

This file was downloaded  
from the RTFM Library.

Link: [www.scottbouch.com/rtfm](http://www.scottbouch.com/rtfm)

Please see site for usage terms,  
and more aircraft documents.



TELEBRIEF  
CONNECTIONS

E