

## Chapter 2

### STANDARD S.B.A.C. WIRING SYSTEM

#### LIST OF CONTENTS

	Para.		Para.
Introduction ... ..	1	Connector block covers ... ..	12
Description		Heavy-duty series ... ..	13
19-amp. series ... ..	2	Connector blocks ... ..	14
Connector blocks ... ..	3	Terminal stud ... ..	15
Terminal sockets ... ..	4	Cable lugs ... ..	16
Cable end ferrules ... ..	5	Commoning links ... ..	17
Commoning links ... ..	6	Connector block covers ... ..	18
Connector block covers ... ..	7	Fuse holder series ... ..	19
37-amp. series		Adapters	
Connector blocks ... ..	8	Ferrule adapters ... ..	20
Terminal sockets ... ..	9	Lug adapters ... ..	21
Cable end ferrules ... ..	10	Crimping ... ..	22
Commoning links ... ..	11	Servicing ... ..	23

#### LIST OF ILLUSTRATIONS

	Fig.		Fig.
Typical bomb bay installation ... ..	1	Typical cable loom, showing cable ends prepared for various terminals ... ..	6
Items from 37-amp. and 19-amp. ranges, showing comparative sizes ... ..	2	Panel showing terminal blocks mounted in line ... ..	7
Connector blocks in the 19-amp. range ... ..	3	Junction box, showing cable identification on terminal block covers ... ..	8
Ferrules before and after attachment to cables ... ..	4	Cable end fittings ... ..	9
Heavy-duty lug, lug adapter, and block cover ... ..	5		

#### LIST OF APPENDICES

- 1 List of components
- 2 Identification scheme

#### Introduction

1. The standard S.B.A.C. wiring system is based on the single-pole, single-core principle, using cables run in ducts or conduits between connector blocks. It was originally designed for cables of the "cel," "rubber," and "vin" ranges, but is also used with Pren and other cables. All metal used is non-ferrous to reduce risk of depreciation through corrosion. A list of the parts, with their Stores Ref. numbers, is given in Appendix 1, and details of the identification scheme used with this system in Appendix 2. A typical bomb bay installation is shown in fig. 1, and further illustrations of the system are given in fig. 6, 7, and 8.

#### DESCRIPTION

##### 19-amp. series

2. The components in this series cover requirements of wiring for 4, 7, and 19-amp. capacity, and are designed to give the maximum degree of flexibility with the minimum number of parts.

##### Connector blocks

3. Connector blocks in this range (fig. 2 and 3) are made in 2, 3, 5, and 15-way sizes. Each block of moulded plastic material is supplied bare, and the dividing walls between the socket channels are high enough to allow

(A.L.67, June 56)

RESTRICTED

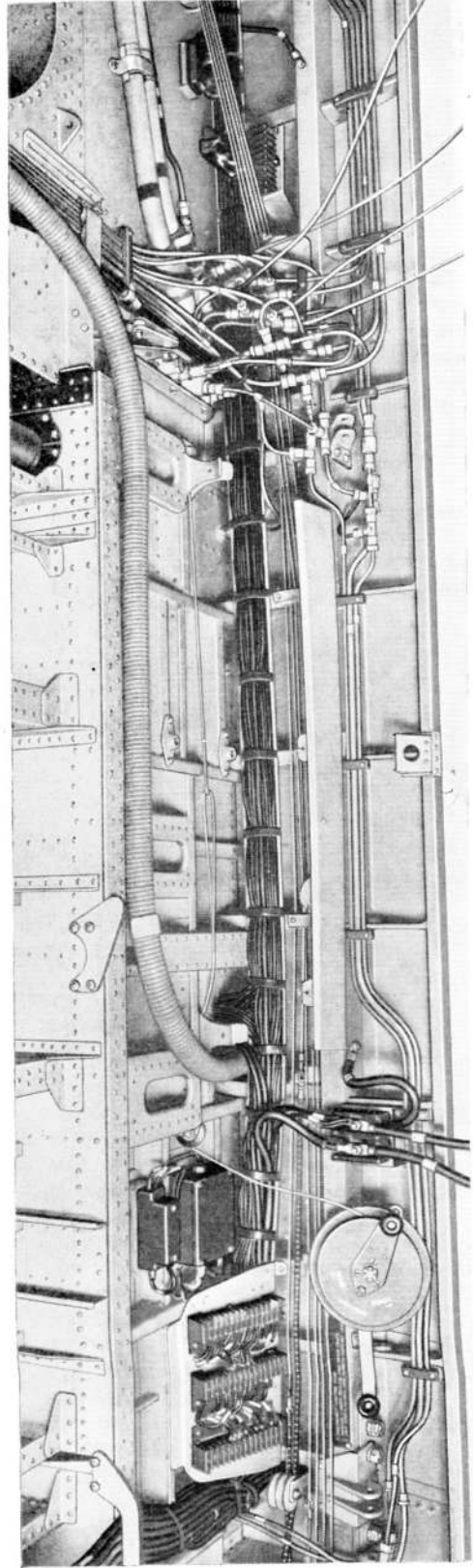
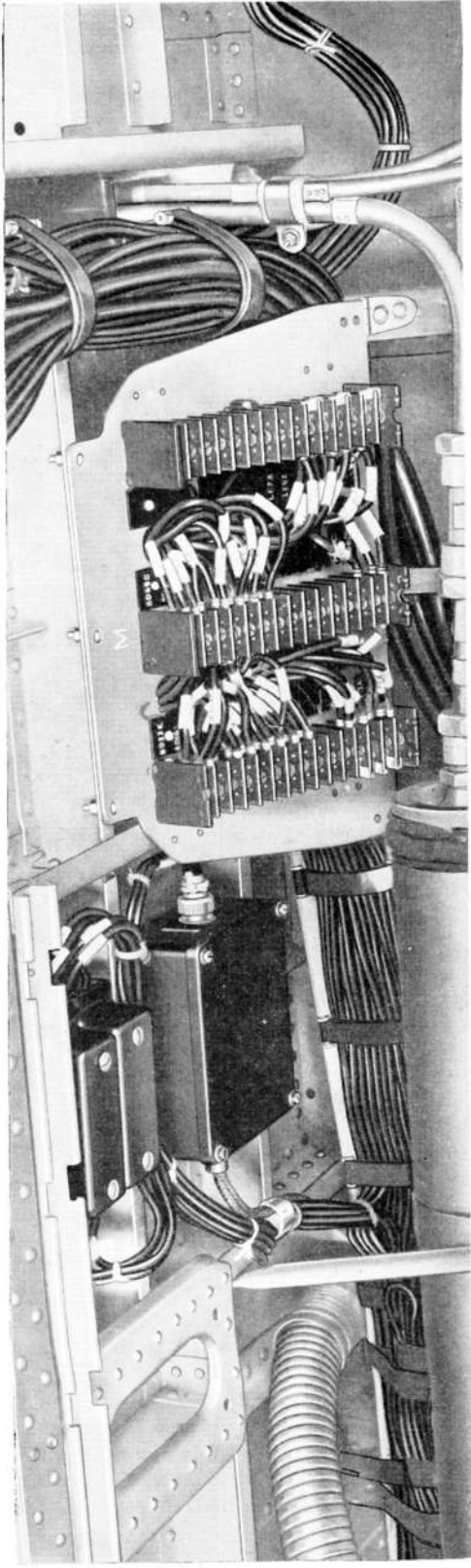
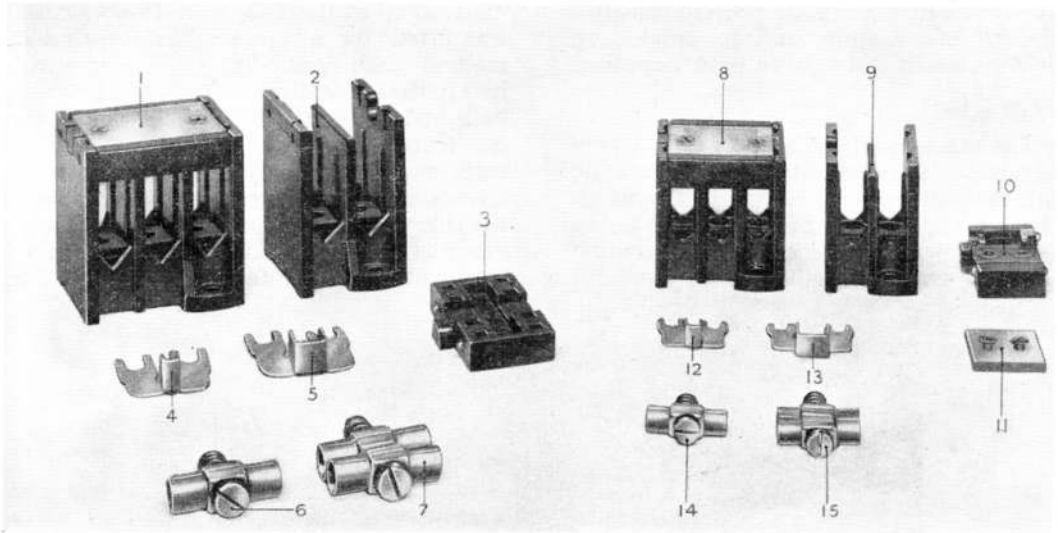

Fig. 1. Typical bomb bay installation



**37-AMP. RANGE**

- 1 3-WAY BLOCK
- 2 2-WAY BLOCK
- 3 2-WAY BLOCK COVER (UNDERSIDE)
- 4 INTER-TERMINAL COMMONING LINK
- 5 INTER-BLOCK COMMONING LINK
- 6 SINGLE-TIER SOCKET
- 7 DOUBLE-TIER SOCKET

**19-AMP. RANGE**

- 8 3-WAY BLOCK
- 9 2-WAY BLOCK
- 10 COVER FOR 2-WAY BLOCK (PERSPEX REMOVED)
- 11 PERSPEX FOR 2-WAY BLOCK COVER
- 12 INTER-TERMINAL COMMONING LINK
- 13 INTER-BLOCK COMMONING LINK
- 14 SINGLE-TIER SOCKET
- 15 DOUBLE-TIER SOCKET

**Fig. 2. Items from 37-amp. and 19-amp. ranges, showing comparative sizes**

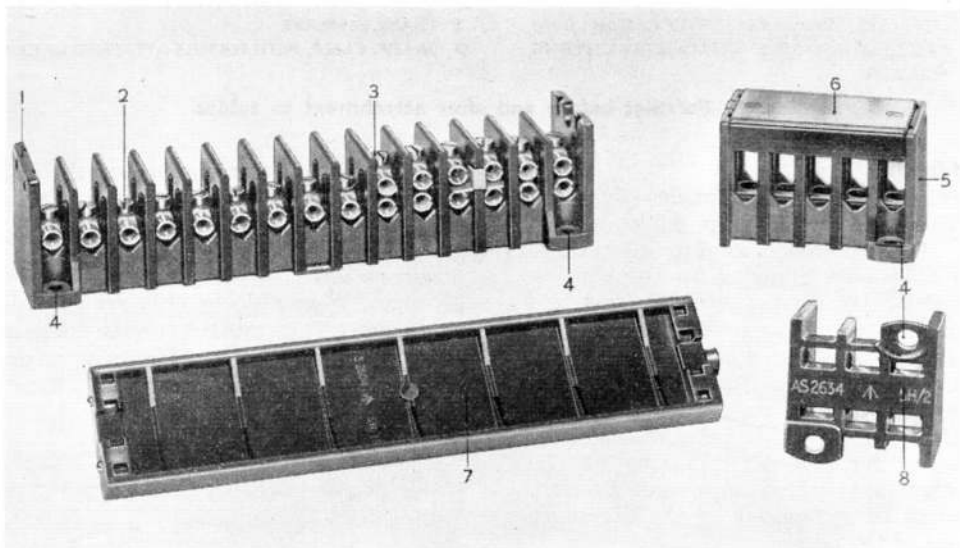

- 1 END WALL OF 15-WAY BLOCK
- 2 SINGLE-TIER SOCKET
- 3 DOUBLE-TIER SOCKET
- 4 FIXING SCREW HOLES

- 5 5-WAY BLOCK
- 6 TRANSPARENT COVER OVER CABLE IDENTIFICATION
- 7 15-WAY BLOCK COVER (UNDERSIDE)
- 8 3-WAY BLOCK (UNDERSIDE)

**Fig. 3. Connector blocks in the 19-amp. range**

for either single or double-tier sockets. As can be seen in fig. 3, the blocks are designed with ventilation holes to prevent possible collection of moisture, and to provide an "airflow" which will help to limit corrosion.

#### Terminal sockets

4. The make-up of the sockets can be seen in fig. 2. Each complete socket assembly, single or double-tier as required, is built up of two or four socket halves held together on captive screws, spring-locked by a securing washer above the thread.

#### Connector block covers

7. The block covers, made of moulded material to fit the 2, 3, 5, or 15-way blocks, are fitted by a quick-release, spring-ball method, each spring-ball registering with a hole in the end wall of the block. These spring balls and their registering holes can be seen on items 9 and 10 in fig. 2. A locating register at one end only of each cover fits into a recess in one of the end walls, thus ensuring the correct replacement of the cover. This is essential, as identification for the terminals is provided by a white cellulose lable, which

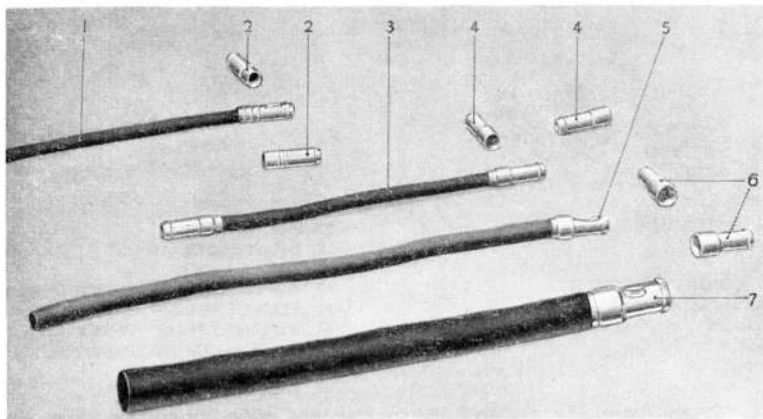

- 1 4-AMP. CABLE, WITH FERRULE ATTACHED BY CRIMPING
- 2 4-AMP. FERRULES, SHOWING IDENTIFICATION RING
- 3 7-AMP. CABLE, WITH FERRULES ATTACHED BY CRIMPING
- 4 7-AMP. FERRULES

- 5 19-AMP. CABLE, WITH FERRULE ATTACHED BY CRIMPING
- 6 19-AMP. FERRULES
- 7 37-AMP. CABLE, WITH FERRULE ATTACHED BY CRIMPING

Fig. 4. Ferrules before and after attachment to cables

#### Cable end ferrules

5. There are three sizes of ferrules (fig. 4 and 9), to take 4, 7, and 19-amp. cables respectively. The difference in size affects the internal bore only, allowing for the varying sizes of the cable used; the nipple end is a standard size, to give constant contact in the standard 19-amp. series socket. Ferrules are mechanically attached to the cables by crimping the cable entry end on to the conductor. The 4-amp. ferrule can be distinguished by the identification ring at the cable entry end; the 7-amp. and 19-amp. ferrules can be recognised by the difference in the size of the bore.

#### Commoning links

6. Two sizes of commoning link (fig. 2) are available in the 19-amp. series. The Type A is used for linking adjacent terminals within one block, and the Type B for connecting the end terminals of two adjacent blocks.

is protected by transparent synthetic resin or Perspex, screwed to the top of the cover.

#### 37-amp series

##### Connector blocks

8. 2 and 3-way blocks only are provided in this range. They are larger than those in the 19-amp. range, but are identical in design; comparative sizes are shown in fig. 2.

##### Terminal sockets

9. Either single or double-tier sockets are available, to take one size of ferrule nipple only (fig. 2).

##### Cable end ferrules

10. Since this range is for a 37-amp. supply exclusively, only one size of ferrule is provided. As in the 19-amp. range, the ferrule is mechanically connected to the conductor by crimping. Fig. 4 shows an example of a ferrule on a 37-amp. cable.

RESTRICTED

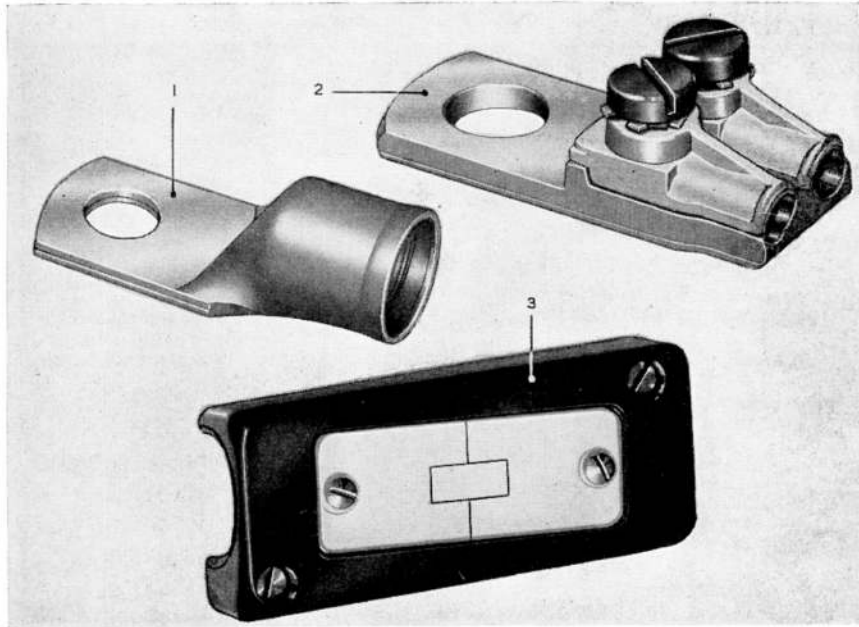

1 CABLE LUG  
2 CABLE LUG ADAPTER  
3 CONNECTOR BLOCK COVER

**Fig. 5. Heavy-duty lug, lug adapter, and block cover**

#### Commoning links

**11.** Two sizes of commoning link are available (*fig. 2*), Type A for inter-terminal connection on one block, and Type B for connecting end terminals of adjacent blocks.

#### Connector block covers

**12.** Two sizes of cover are available in this range to fit the 2 and 3-way blocks; they are of the same design as the covers described in para. 7.

#### Heavy-duty series

**13.** The heavy-duty range is used for 64-amp., 83-amp., and 138-amp. capacity cables, and the design of the components is based on the existing screw-down type of lug. Various items in the range are shown in *fig. 5* and 9.

#### Connector blocks

**14.** Three types of block are provided in this range; one is adaptable to take various arrangements of connections, and has a base of moulded plastic material. The other two, which are both 3-way blocks, are pressure-proof, and are for use on bulkheads.

#### Terminal stud

**15.** A terminal stud, complete with a self-locking nut, is moulded into the centre of the base. The various lugs making up the electrical connection on this terminal are slipped over the stud, and held down by the stiff nut.

#### Cable lugs

**16.** There are three sizes of lugs in this range, for 64, 83, and 138-amp. cables respectively; each can be either straight or right-angled. The lugs are mechanically connected to the cables by crimping the lug on to the cable core.

#### Commoning links

**17.** The side walls of the heavy-duty block base are cut away to allow for a commoning link to connect the terminal studs of two adjacent blocks.

#### Connector block covers

**18.** Two types of cover are provided, for  
(A.L.67, June 56)

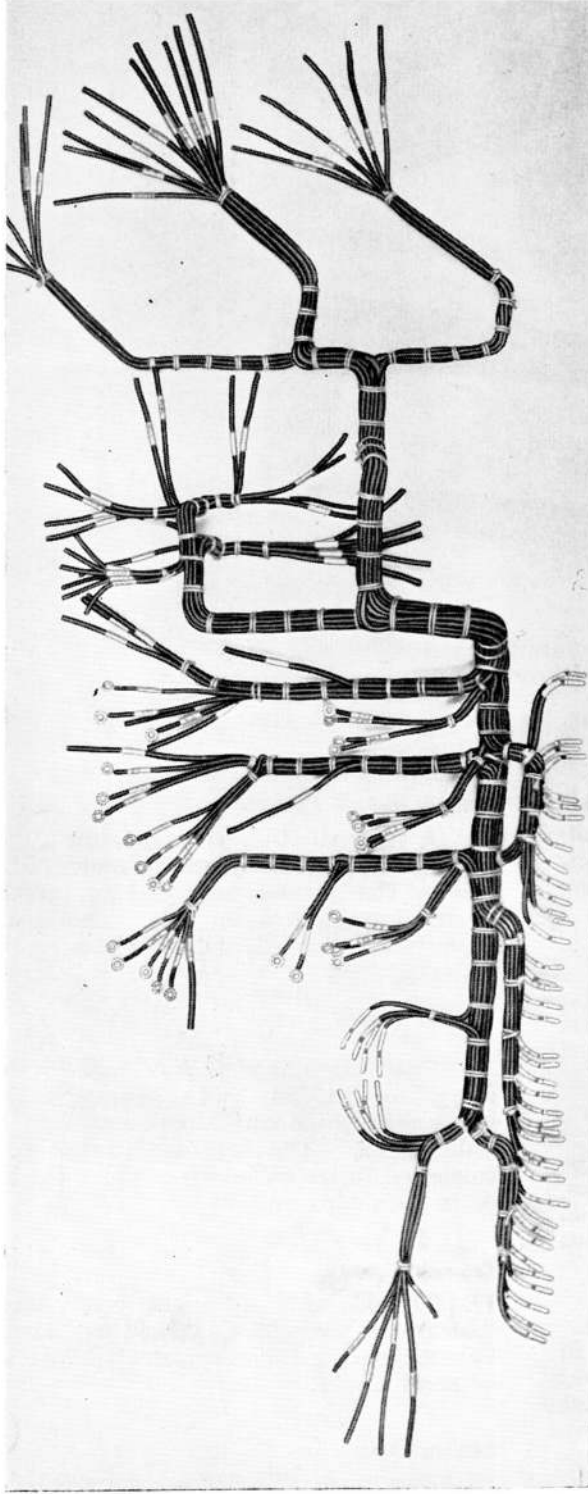

Fig. 6. Typical cable loom, showing cable ends prepared for various terminals

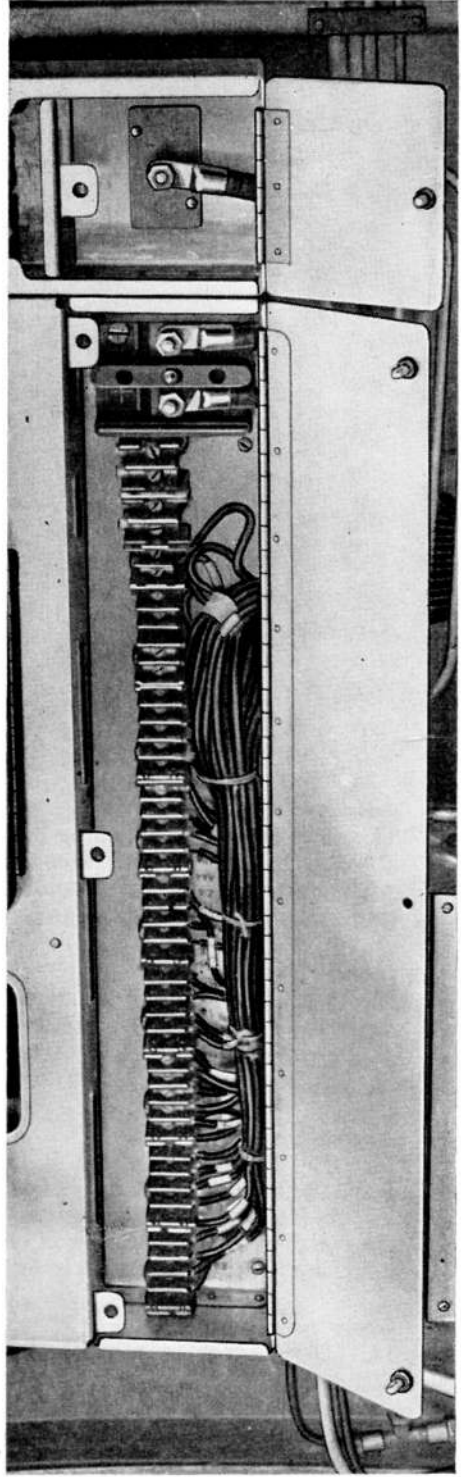
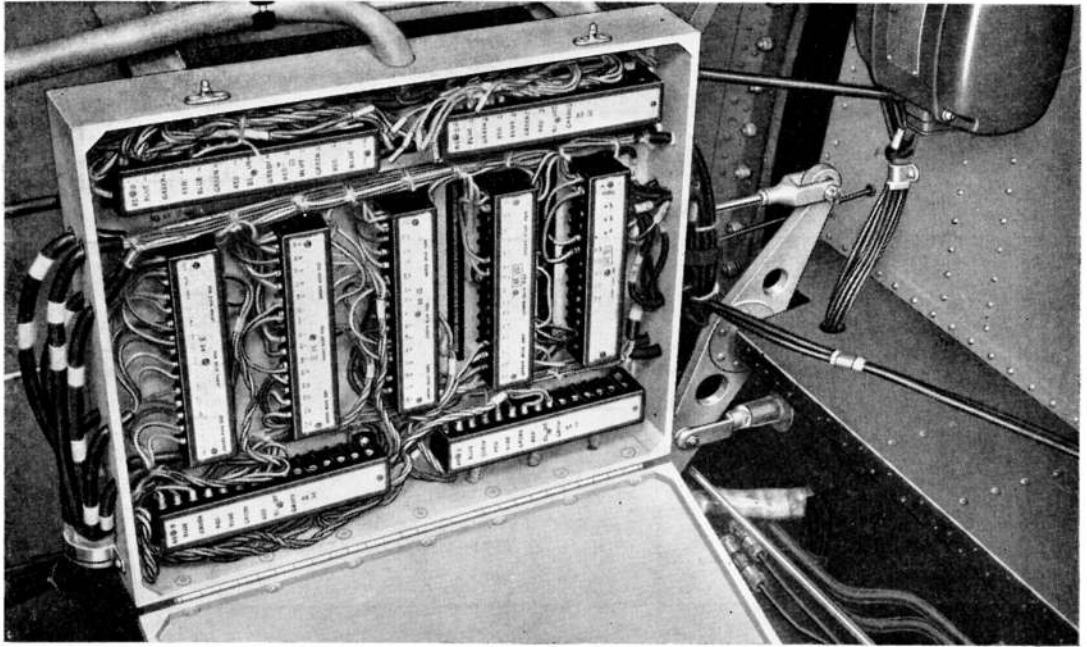

Fig. 7. Panel showing terminal blocks mounted in line



**Fig. 8. Junction box, showing cable identification on terminal block covers**

the standard and bulkhead type blocks respectively. The cover is so designed that it is impossible to replace it incorrectly. A label, protected by Perspex and fastened to the cover by captive screws, identifies the terminal and associated cable connections.

#### **Fuse holder series**

**19.** There is an additional series of components, consisting of connector block covers, socket assemblies, bases and bus-bars, as listed in Appendix 1; these differ from those items already described in that there is provision for incorporating fuses, Type S, in the installation.

#### **Adapters**

##### *Ferrule adapters*

**20.** These adapters, typical examples of which are shown in fig. 9, are provided to enable ferrules in one range to be used in terminal sockets of another range. One end of the adapter fits over the nipple of the cable end ferrule; the other end is of the size

appropriate to the terminal socket. The adapters, which are listed in Appendix 1, have been developed to simplify modification work, and their use should be limited.

##### *Lug adapters*

**21.** There are three types of lug adapters, shown in fig. 9, which enable cables in the 19 and 37-amp. range to be connected on the heavy-duty terminals. These adapters have cable-entry ends designed to take two 19-amp. ferrules, four 19-amp. ferrules, and two 37-amp. ferrules, respectively.

##### *Crimping*

**22.** Instructions for crimping the ferrules, ferrule adapters and lugs on to the cable ends will be found in A.P.4343, Vol. 1, Sect. 12, Chap. 5. Special crimping tools are required, which are listed in Appendix 1.

#### **SERVICING**

**23.** General information on the servicing of aircraft wiring systems is given in A.P.4343, Vol. 1, Sect. 12, Chap. 5.

FERRULES

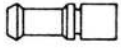

4 AMP.

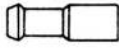

7 AMP.

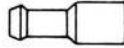

19 AMP.

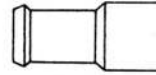

37 AMP.

FERRULE ADAPTERS

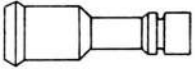

4 AMP.

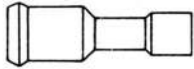

7 AMP.

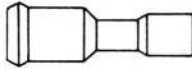

19 AMP.

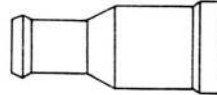

64 AMP.

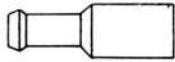

37 AMP. FERRULE ADAPTER  
FOR USE WITH 19 AMP. TERMINAL BLOCK

CABLE LUG ADAPTERS

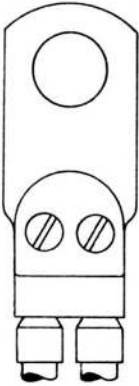

19 AMP 2 WAY  
19 AMP 4 WAY

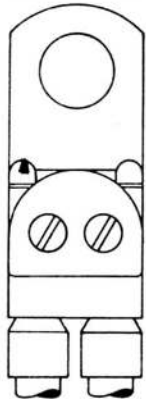

37 AMP. 2 WAY

CABLE LUGS



64 AMP.



83 AMP.

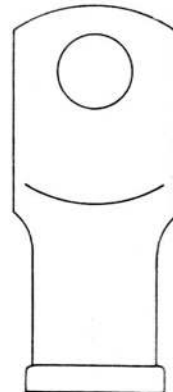

138 AMP.

Fig. 9. Cable end fittings

RESTRICTED

This file was downloaded  
from the RTFM Library.

Link: [www.scottbouch.com/rtfm](http://www.scottbouch.com/rtfm)

Please see site for usage terms,  
and more aircraft documents.

