

## Chapter 9

### EXTERNAL SUPPLY SOCKETS

#### LIST OF CONTENTS

	Para.		Para.
Introduction...	1	Type E2 ...	5
Description		Servicing ...	7
Type E1 ...	2		

#### LIST OF ILLUSTRATIONS

		Fig.
External supply socket, Type E1 ...		1

#### LEADING PARTICULARS

<b>External supply socket, Type E1</b> ...	Stores Ref. 5CY/859
Diameter (excluding terminal lugs and covers) ...	3¼ in.
Weight (excluding terminal lugs and covers) ...	9½ oz.
<b>External supply socket, Type E2</b> ...	Stores Ref. 5CY/2225
Diameter (excluding terminal lugs and covers) ...	3¼ in.
Weight (excluding terminal lugs and covers) ...	8 oz.

#### Introduction

1. The external supply socket enables a heavy duty ground battery to be connected to the aircraft for engine starting, and ground testing of electrical and radio equipment, thus saving the imposition of heavy loads on the aircraft battery. It may or may not be used in conjunction with the ground/flight switch; as installations vary from aircraft to aircraft, reference should be made to the relevant Aircraft Handbook for individual installation details.

#### DESCRIPTION

##### Type E1

2. The socket, Type E1 (*fig. 1*), is constructed of black moulded insulating material. The cover is held by a central fixing screw and is secured against vibration by a hexagon lock-nut at the back of the socket. A felt washer is fitted at the point of contact between the lid and the base to exclude dust and moisture from the interior of the unit.

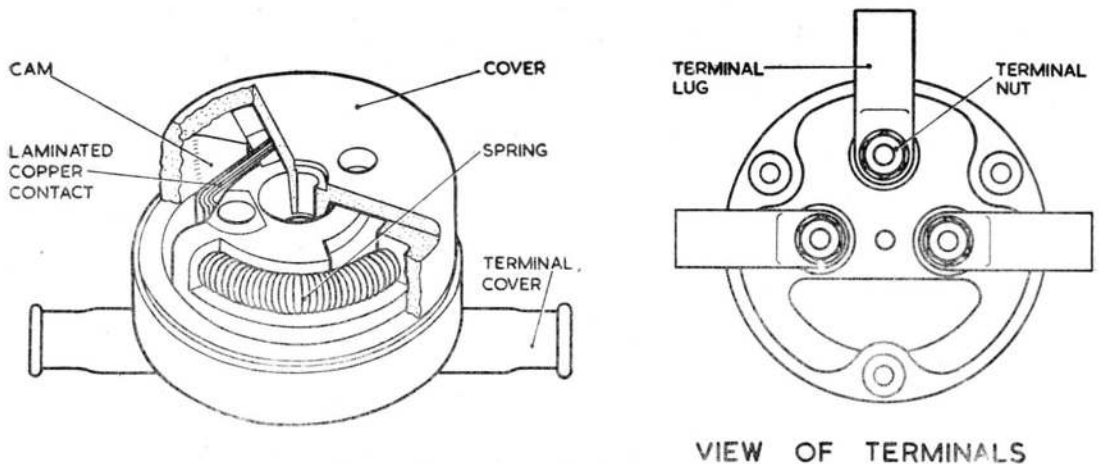

Fig. 1. External supply socket, Type E1

**RESTRICTED**

(A.L.3, Sept. 54)

3. To insert the ground starter trolley plug, the socket cover must be turned in a clockwise direction against the action of a coil spring shown in fig. 1. Pressure is then removed from the laminated copper contact and the connection between the terminals marked B- and M2 is broken. The plug can then be inserted. When the plug is removed, the spring restores the socket cover to its original position, and pressure from the raised cam on the inside of the lid closes the copper contact, completes the connection between B- and M2, and brings the aircraft battery back into circuit. In order that the plug shall be inserted correctly the socket inserts are of unequal sizes, that marked B+ being the larger of the two.

4. The terminals are situated at the back of the socket, each terminal being appropriately marked. The terminal lugs are secured to the terminal pillars by hexagon nuts and spring washers, and each assembly is fitted with a rubber cover.

#### **Type E2**

5. The external supply socket, Type E2, is for use on aircraft where ground/flight switches are fitted. The external appearance of this socket is similar to the Type E1, except that it has only two terminals, marked + and -; the terminal marked + is connected to the larger of the two inserts. In addition, the internal isolating switch is omitted.

6. The use of the socket is identical with that of the Type E1 socket, and the ground starter trolley plug can be inserted only after turning the socket cover in a clockwise direction to its extreme position.

#### **SERVICING**

7. Should it be necessary to take off the cover of the Type E1 to inspect the interior of the socket, care must be taken not to lose the spring when the compression under which it is normally kept is removed. The copper contacts should be kept clean and the laminations should not be bent or disturbed in any way. The contact gap measured at the centre of the contact with the cover removed must be between 1 mm. and 1.2 mm.

**RESTRICTED**



This file was downloaded from the RTFM Library.

Link: [www.scottbouch.com/rtfm](http://www.scottbouch.com/rtfm)

Please see site for usage terms, and more aircraft documents.

