

## Chapter 5

### SWITCH, STARTING (ROTAX UI707)

#### LIST OF CONTENTS

	Para.		Para.
Introduction...	1	Installation ...	10
Description ...	3	Servicing ...	11
Operation ...	5	Insulation resistance test ...	12

#### LIST OF ILLUSTRATIONS

	Fig.		Fig.
Starting switch, Rotax UI707 ...	1	Circuit diagram ...	2

#### LEADING PARTICULARS

Voltage to starter ...	112 volt d.c.
Relay operating voltage ...	28 volt d.c.
Starter current ...	400 amp.
Electrical connection	
112 volt d.c. ...	3-way terminal block, Type F (Stores Ref. 5CZ/931)
28 volt d.c. ...	5-way 19 amp. terminal block (Stores Ref. 5H/125)
Weight ...	27.5 lb.

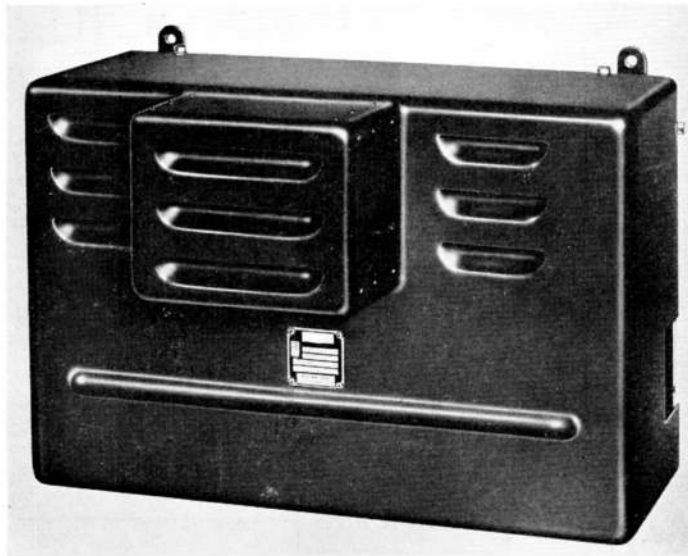

Fig. 1. Starting switch, Rotax UI707

## Introduction

1. This unit is designed to regulate starting current for 112 volt d.c. gas turbine starters. It gives a two-stage starting cycle and incorporates an overspeed cut-out.

2. On multi-engine aircraft only one unit is required, used with an engine selector switch. A 28 volt d.c. supply is required to operate the relays.

## DESCRIPTION

3. The U1707 starting switch consists of a light alloy panel upon which are mounted identical main and engaging relays. (Stores Ref. 5CW/4318) with an overspeed relay (Stores Ref. 5CW/4760) and a time delay switch (Stores Ref. 5CW/4719). These are bolted to the panel and wound as shown in the circuit diagram (fig. 2). Copper busbars are used for internal high voltage connections. The complete starter panel is protected by a louvred, drip proof cover.

4. Also mounted on the panel are terminal blocks as described in the leading particulars. A part of the starter circuit which is essential

to the operation of the panel, but not included in it, is a hold-on switch (Stores ref. 5CW/4403 or other similar type) as shown in the circuit diagram (fig. 2).

## OPERATION

5. Pressing the button of the external hold-on switch (para. 4) makes a 24 volt supply through terminal P. on the panel to the coil of the engaging relay, via a pair of contacts on the time delay switch. When the engaging relay operates it makes the 112 volt d.c. supply through the engaging resistor and overspeed relay coil to terminal ST and thence to the starter.

6. The overspeed relay is now energized thereby connecting the hold-on coil of the external switch across the 28 volt d.c. supply. At the same time the motor of the time delay switch starts running as the current reaches it through terminal M. Linked to terminal M are the contacts for the main relay—these contacts of the time delay switch close as the delay switch commences its operating cycle, thus putting 28 volt d.c. across the main relay coil.

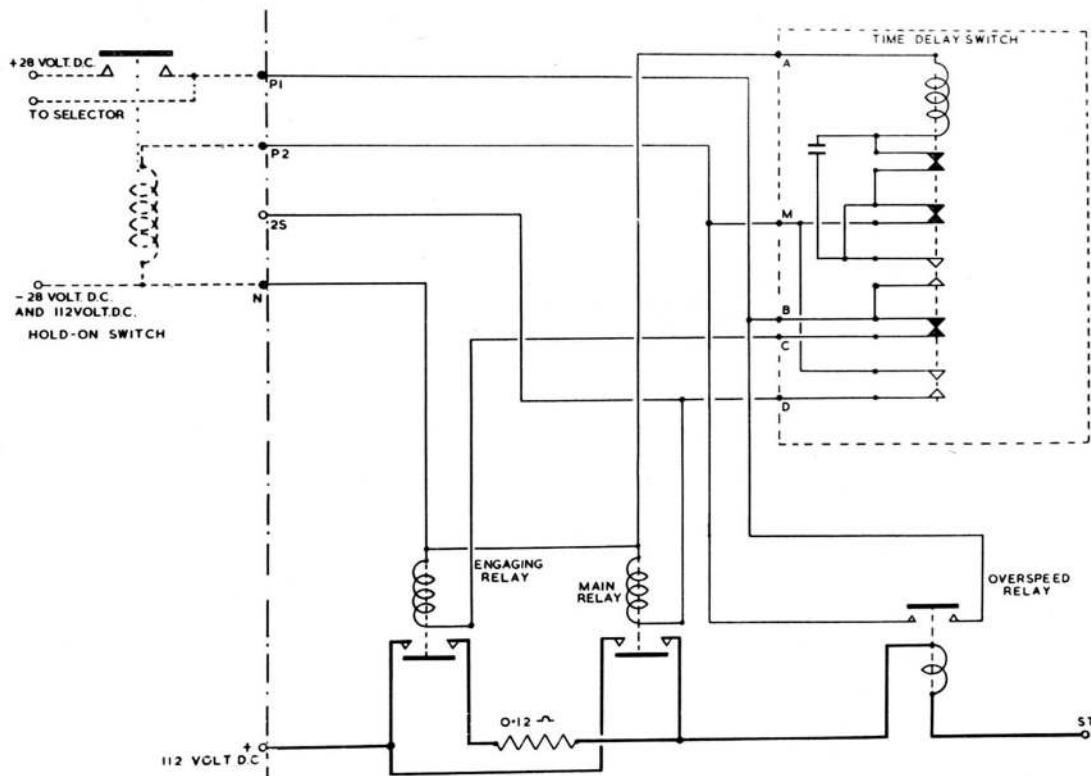

Fig. 2. Circuit diagram

**RESTRICTED**

7. The main relay contacts now close so that the contacts of the engaging relay are shorted out, together with the engaging resistor. The 112 volt d.c. supply is then connected direct to terminal ST, allowing the starter to receive the full current. The first pair of contacts on the time delay switch now break, de-energizing the engaging relay.

8. When the self-sustaining speed of the engine is reached, the starter current decreases with the load. When the current falls to 85 amp.  $\pm 10-5$ , the overspeed relay is tripped, breaking the circuit. If the engine fails to start, the contacts of the time delay switch finally break and trip the main relay.

9. The time-delay switch then comes to rest in its original position, reset for the next starting cycle.

#### INSTALLATION

10. The panel should be mounted with the resistance assembly uppermost in a vertical plane. It is fitted by means of four lugs with

holes 0.265 in. dia. spaced 12.5 in. by 10.625 in. at centres. These fittings will withstand a 25g. acceleration.

#### SERVICING

11. Servicing of these panels should be carried out in position in the aircraft, the tightness and cleanliness of leads and terminals being tested before an insulation resistance test (*para.* 12) is made. The terminals should then be disconnected from any live or earthed leads.

#### Insulation resistance test

12. The insulation resistance measured between the following points with a 500 volt insulation tester must not be less than 2 megohm between the following points:—

1. Terminal + and terminals ST, N and the frame.
2. Terminal ST and terminal N and the frame.
3. Terminal N and the frame.

This file was downloaded  
from the RTFM Library.

Link: [www.scottbouch.com/rtfm](http://www.scottbouch.com/rtfm)

Please see site for usage terms,  
and more aircraft documents.

