

Chapter 7

SWITCH, STARTING (ROTAX U2201)

LIST OF CONTENTS

	Para.		Para.
Introduction... ..	1	Servicing	7
Description	2	Resistance tests	8
External connections	4	Pull-in voltage test	9
Operation	5	Millivolt drop test	10
Installation	6	Insulation resistance tests	11

LIST OF ILLUSTRATIONS

	Fig.		Fig.
U2201 starting switch	1	Diagram of internal connections	3
Starter unit with cover removed	2		

LEADING PARTICULARS

Switch, magnetic, starting (Rotax U2201)	Stores Ref. No. 5CW/4397
Starting resistance (20 deg. C)	0.225 ohm. \pm 10 per cent
Coil resistance (20 deg. C.)	85 ohm. \pm 10 per cent
Operating voltage (terminals 3 and 4)	71-V d.c.
Operational ceiling	50,000 ft.
Operational temperature range... ..	- 65 deg. C. to + 70 deg. C.
Length	13.312 in.
Width (including mounting lugs)	5.374 in.
Height	5.312 in.
Weight	7 lb. 10 oz.

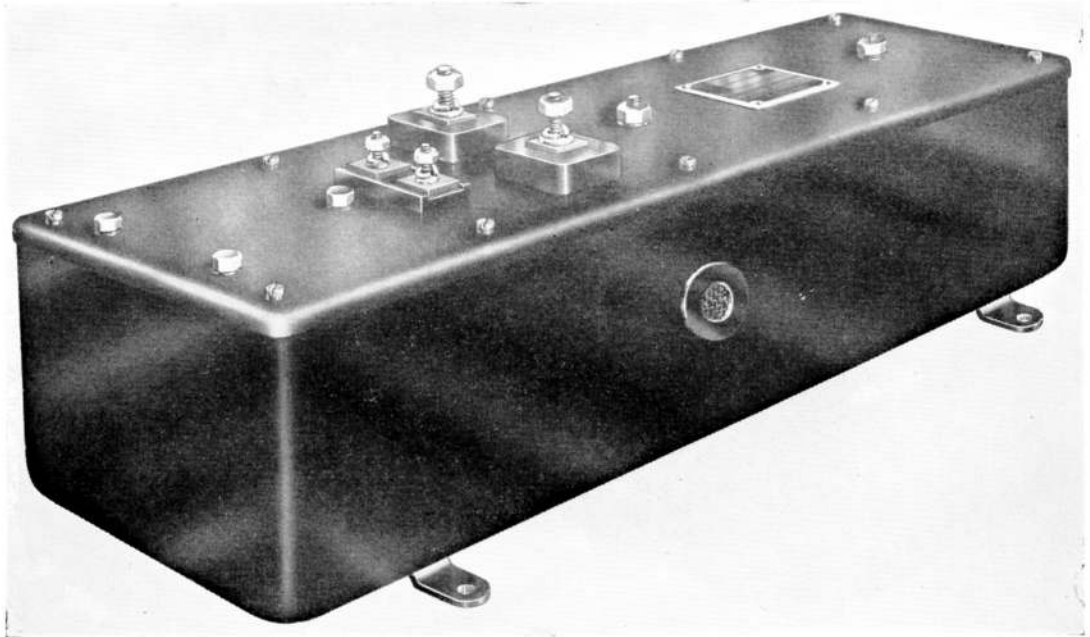

Fig. 1. U2201 starting switch

Introduction

1. Type U2201 starter unit is designed for use in circuit with a 112 volt d.c. motor in order to limit the initial current surge at the moment of switching on. A starting resistance is in circuit with the motor armature until the potential drop across the armature reaches 71 volt whereupon the resistance is shorted out by the action of the contactor portion of the unit. The contactor has a stabilized pull-in voltage under conditions of acceleration.

DESCRIPTION

2. A contactor, and a "Brightway B" starting resistance element are mounted on a sheet metal base. The starting resistance has an insulating mounting board and is supported by two pillars of insulating spacers. An adjustable ballast resistor in the contactor coil circuit is mounted above the starting resistance. Four terminals are set in the base, being insulated from it by moulded bushes and washers. The main terminals of the contactor and the main terminals in the base are connected by copper conductors and the starting resistance is also connected across the main terminals. Connections between the coil, ballast resistor and secondary terminals are made with glass covered flex. A sheet metal cover, having a cowl for ventilation, encloses the components. Two strips are riveted to this cover and, projecting on either side, from four lugs for mounting.

3. The contactor consists of a solenoid coil having two co-axial plungers each of which is connected by a lever to a crank, one on each side of the pin to which a moulded contact carrier is pivoted. There are two moving contacts fitted to a common contact plate which is spring mounted on the contact carrier. The fixed contacts are integral with terminal posts set into the moulded body assembly. When the coil is energized, the two plungers draw in towards one another and the two levers rock the contact carrier against the action of a torsion spring so that the contacts close. The opposed plungers ensure a constant pull-in voltage under all conditions of acceleration.

External connections

4. The main terminals (terminals 1 and 2) are $\frac{1}{4}$ in. B.S.F. studs whilst the secondary terminals (terminals 3 and 4) are 2 B.A. studs.

Operation

5. The operation of this unit depends on the starting resistance being connected in series with the armature of the motor and the solenoid of the contactor being connected in parallel with the armature. When the motor is switched on, the starting resistance (0.225 ohm) limits the current surge through the armature but when the motor gathers speed and the potential drop across the armature (due to the generated back e.m.f.)

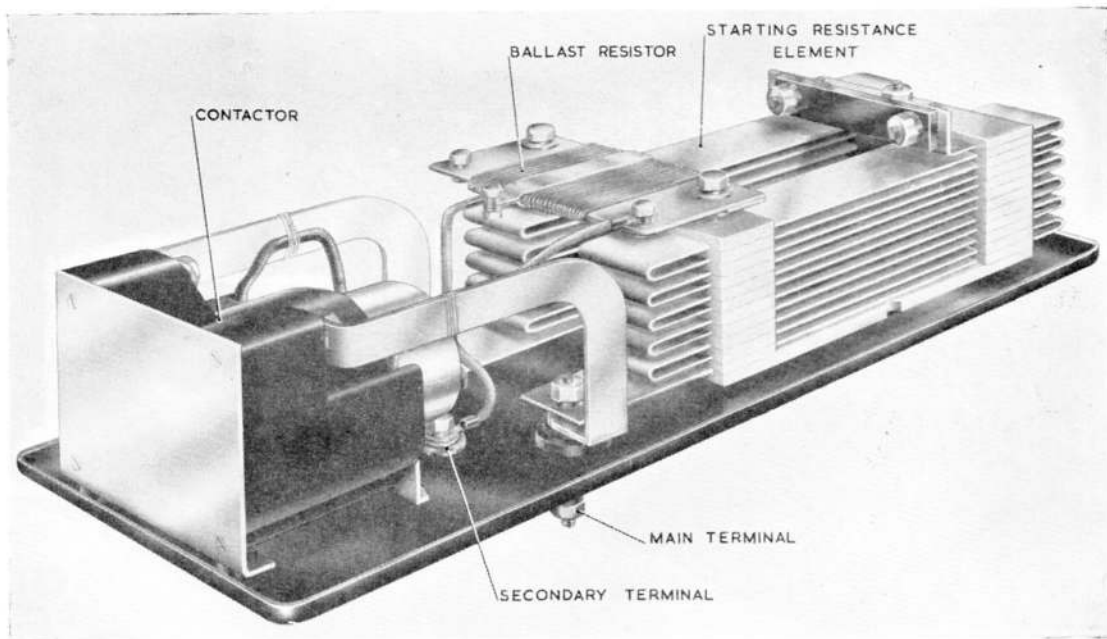

Fig. 2. Switch unit with cover removed

RESTRICTED

risers to 71 volt the contactor operates and the starting resistance is shorted out. The contactor opens again immediately the motor is switched off.

INSTALLATION

6. The unit may be mounted in any attitude. Four 0.257 in. diameter holes are provided for mounting; their fixing centres form a rectangle 8.000 in. by 4.750 in.

SERVICING

7. The tests detailed in paras. 8, 9, 10 and 11 are sufficient to ensure satisfactory operation of the unit. In addition, the unit should be examined for superficial damage.

Resistance tests

8. Measure the resistance of the solenoid coil, the solenoid coil with ballast resistor and the starting resistor. When corrected to 20 deg. C. the resistance of the solenoid coil should be $85 \text{ ohm} \pm 10$ per cent and the resistance of the solenoid coil with ballast resistor should be approximately 483 ohm. The starting resistance, when corrected to 20 deg. C., should be $0.225 \text{ ohm} \pm 10$ per cent.

Pull-in voltage test

9. With the unit in a horizontal position, measure the minimum pull-in voltage, as applied across terminals 3 and 4. A reading of between 69-V and 72-V d.c. should be obtained.

Millivolt drop test

10. With the contactor of the unit energized, allow 150 amperes to flow through the contacts and measure the potential drop across terminals 1 and 2. A reading of not more than 180 millivolt should be obtained.

Insulation resistance tests

11. Measure the insulation resistance between the following points using a 250-volt insulation resistance tester.

Terminal 1 and frame

Terminal 3 and frame

Terminal 2 and Terminal 3

A reading of not less than 2 megohm should be obtained in each test.

Note . . .

The value given in this insulation resistance test applies to units being tested under normal workshop conditions. Due allowance must be made for climatic conditions of the locality and those of the aircraft servicing area or dispersal point where tests are being conducted. In particularly damp climates, the readings may be low enough to give apparently sufficient reason for rejection and in these instances, discretion should be exercised.

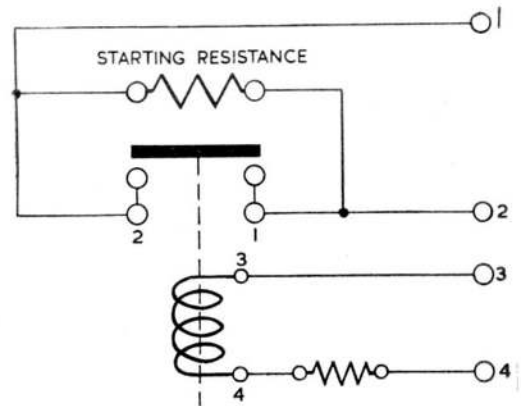

Fig. 3. Diagram of internal connections

This file was downloaded
from the RTFM Library.

Link: www.scottbouch.com/rtfm

Please see site for usage terms,
and more aircraft documents.

