

Chapter 9

SWITCHES, STARTING (ROTAX U2601 AND U2602)

LIST OF CONTENTS

	Para.		Para.
Introduction	1	Servicing	9
Description	2	Operation test	10
Operation	4	Insulation resistance test	11
Installation	7		

LIST OF TABLES

	Table
Times and resistance during cycle	1

LIST OF ILLUSTRATIONS

	Fig.		Fig.
U2601 starting switch	1	Composite starting circuit	3
U2602 starting switch	2		

LEADING PARTICULARS

Voltage of main circuit	112-V. d.c.
Voltage of auxiliary and operating circuits	28-V. d.c.
Duration of starting cycle	28-30 seconds
Operational temperature range	-50 deg. C. to +10 deg. C.
Length (U 2601)	19.875 in.
Length (U 2602)	19.750 in.
Width (including mounting feet)	12.375 in.
Height (U 2601)	7.781 in.
Height (U 2602)	7.539 in.
Mounting	Four .265 in. diameter holes in mounting feet whose centres form a rectangle 12.500 in. by 11.625 in.
Weight	35 lb. 8 oz.

Introduction

1. U2601 and U2602 starting switches are intended to control the operation of 112-V. d.c. starter motors. They consist of relays and resistors which operate a four stage starting sequence controlled by a time delay switch, together with an overspeed cut-out device which automatically discontinues the supply to the starter when it has started its engine and a time-limit cut-out which

stops the starter at the end of its rated period of operation in the event of the engine failing to start. The two starting switch units are identical in every respect except that the U2602 unit is not provided with a cover.

DESCRIPTION

2. Since the two switches are identical, with the exception that the U2602 unit has no

(A.L.68, Jul. 56)

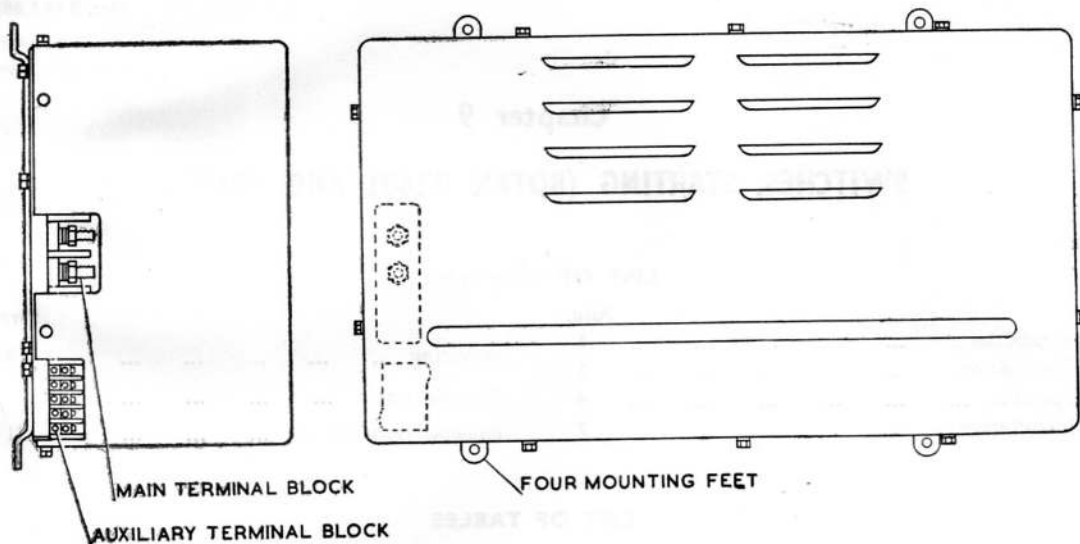

Fig. 1. U2601 starting switch

cover, no further reference will be made to the two types in the course of this chapter.

3. The unit consists of a number of components mounted on a sheet metal base. The components are:—four D6106 magnetic switches, one F1711 magnetic switch, one D8134 time delay switch, one resistor assembly (consisting of two resistors of folded "Brightray B" strip supported by two columns of insulating spacers and one resistor

consisting of two coils of "Brightray B" wire) and two terminal blocks, one for 112-V. connections and another for 28-V. connections. 112-V. connections within the unit are made by copper conductor bars and 28-V. connections by glass covered flex. Two strips are riveted to the underside of the base and, projecting on each side, provide the four mounting holes. A sheet metal cover (U2601 only) encloses the components and is secured

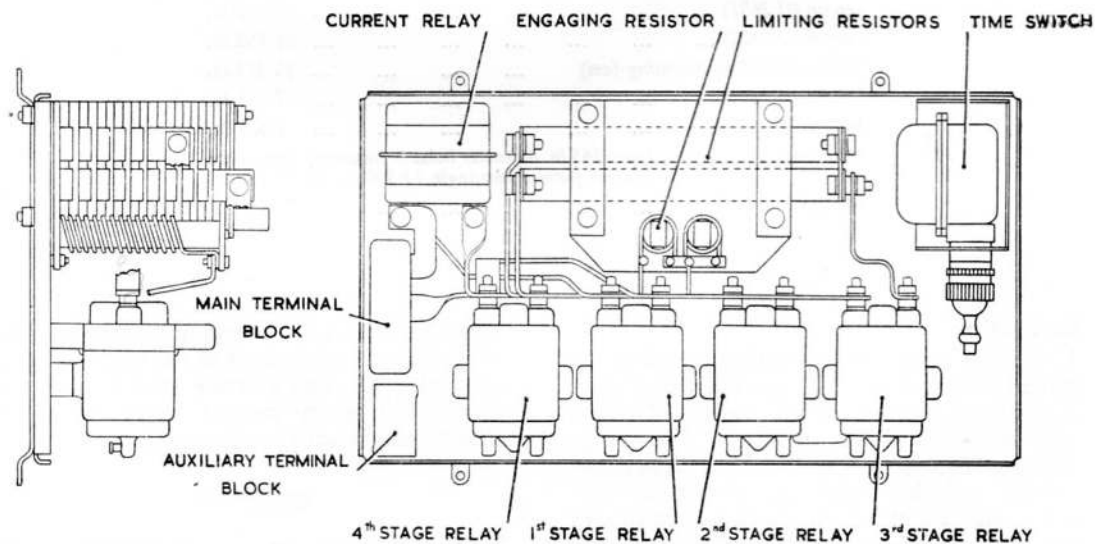

Fig. 2. U2602 starting switch

RESTRICTED

by ten screws. It has four ventilation louvres.

OPERATION

4. The operation of this unit can only be fully understood when considered in conjunction with the starters, starter relays, selector switch and push button switch (with hold-on coil) with which it is associated and these are included in the composite wiring diagram of a typical installation, fig. 3. Terminals 2S and 3S are connected to ancillary equipment intended to be operated at the second and third stages respectively. The pairs of contacts numbered 1 to 4 in the time delay switch operate in that order to control the stages of starting; the remainder of the time switch circuit is relevant only to the operation of the switch itself and is not referred to in this chapter.

5. Before operating the starting switch, the operator selects, at the selector switch, the starter to be used. On depressing the starter button, 28-V. d.c. is connected to the starting relay, so that the starter is connected to the starting switch, and 28-V. is also connected to terminal P1 of the starting switch where the first stage relay closes, being energized via contacts 1 of the timer switch. The starter commences to rotate with all three starting resistors in circuit, and current flows through the current relay coil so that the relay closes, connecting 28-V. to the time delay switch mechanism and, via terminal P2, to the hold-on coil of the starter button. The time delay switch commences its cycle immediately and, after $2\frac{1}{4}$ to $3\frac{3}{4}$ seconds, the second pair of timer contacts close, connecting 28-V. to the second stage relay and to terminal 2S on the auxiliary terminal block. The second stage relay cuts out the engaging resistor (R1) and part of the current relay winding and the first pair of timer contacts open thereby de-energizing the first-stage relay. From the commencement of the second stage, only part of the current relay coil is in circuit, this being sufficient to hold the relay in. After $7\frac{1}{2}$ to $8\frac{1}{2}$ seconds from the beginning of the cycle, contacts 3 of the time delay switch close and contacts 2 open; the third stage relay cuts out one limiting resistor while 28-V. d.c. is connected to terminal 3S on the auxiliary terminal block. The second stage relay drops out and the supply to terminal 2S is discontinued. At $12\frac{1}{2}$ to $13\frac{1}{2}$ seconds from the beginning of the

cycle, timer contacts 4 close and contacts 3 open. The fourth-stage relay closes, cutting out the final limiting resistor, whilst the third stage resistor drops out and the 28-V. supply is disconnected from terminal 3S. Full supply is now connected across the starter motor.

6. When the engine starts and reaches self-sustaining speed, the load on the starter motor falls sharply and the current is reduced sufficiently to allow the current relay to drop out so that the starter button is released. The 28-V. supply to the unit is then broken, all the relays are de-energized and the supply to the starter broken. In the event of the engine failing to start after 28 to 30 seconds have elapsed from the commencement of the cycle, the time delay switch opens contacts 4 and the fourth-stage relay drops out, breaking the supply to the starter motor. The current relay drops out, releasing the starter button. In either instance, a further period must elapse before the starter switch can be operated again, during which time the time delay switch completes its cycle of 36 seconds, resetting itself in its normal position with contacts 1 closed and contacts 2, 3 and 4 open.

INSTALLATION

7. The starter switch may be mounted in any convenient position. Four .265 in. mounting holes are provided in the mounting feet; their fixing centres forming a rectangle, 12.500 in. by 11.625 in.
8. The main terminal block (Stores Ref. 5CZ/931) has two $\frac{5}{16}$ in. B.S.F. studs. The auxiliary terminal block has five standard 19 ampere S.B.A.C. sockets (Stores Ref. 5H/125).

SERVICING

9. Examine the starting switch for external signs of damage, for security of mounting and for cleanliness and security of electrical connections.

Operation test

10. Disconnect the external cables from the main terminals and connect a suitable ohmmeter across them before the commencement of the test; the instrument should register an open circuit between the terminals. Short circuit terminals P1 and P2 of the current relay F1711; this will ensure that the starter

(A.L.68, Jul. 56)

RESTRICTED

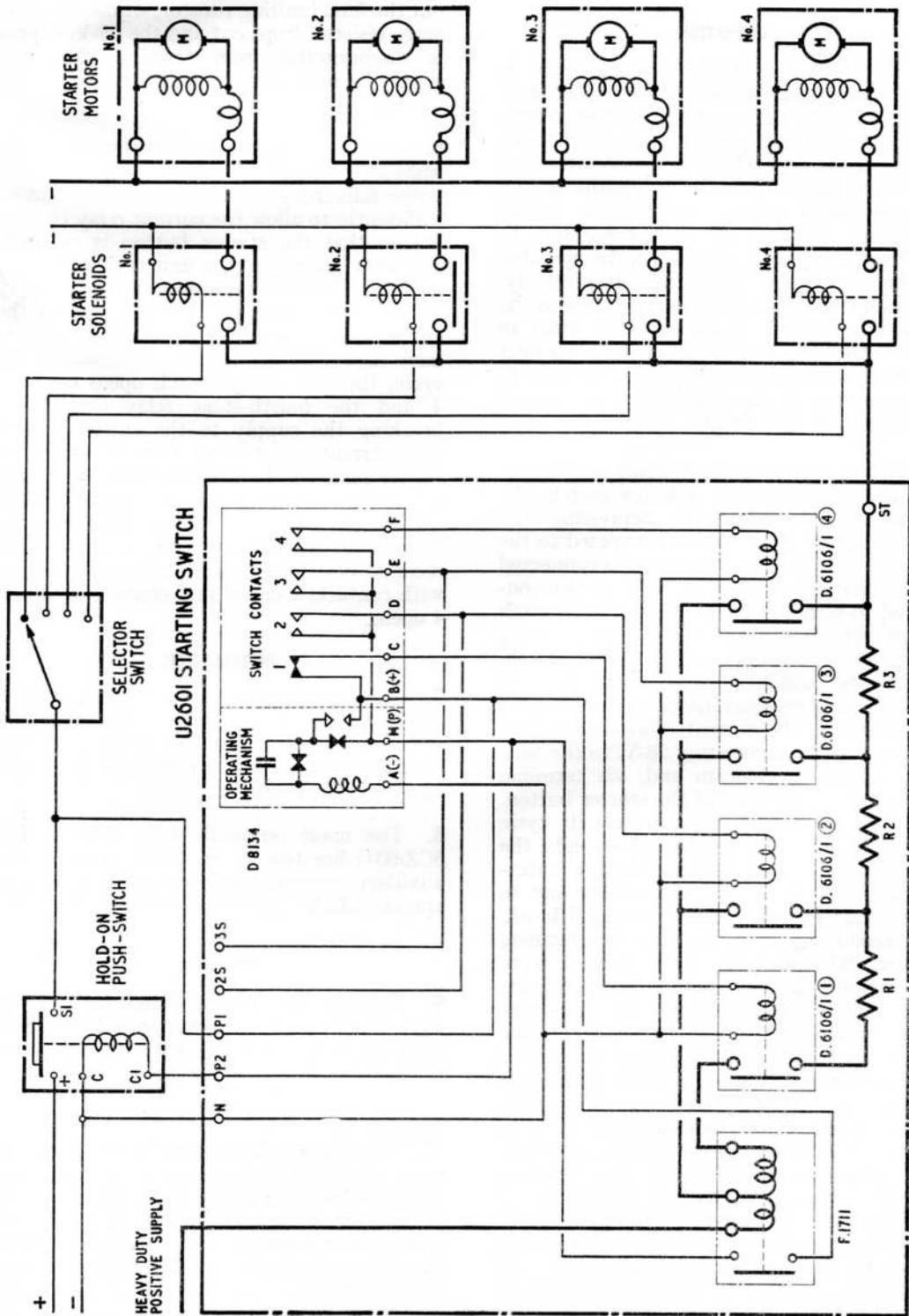

Fig. 3. Composite starting circuit

button is held in at the end of the first cycle so that the second cycle will start immediately. The test consists of two complete cycles of operation. During the first cycle, time the commencement of each stage, noting the ohmmeter readings, and afterwards compare the values obtained with the table below. During the second cycle, ensure that 28-V. d.c. is supplied to terminal 2S for the duration of the second stage and terminal 3S for the duration of the third stage. The starter buttons must be released at the end of the fourth stage by removing the short circuit from the current relay terminals.

Correct functioning of all internal components is indicated if the tests are concluded successfully. Unserviceability of components will be evinced as follows:—

Time delay switch	Timing out of tolerance
Time delay switch contacts	Open circuit at any stage; terminals 2S and 3S not connected to internal supply.
Resistors or connectors	Ohmmeter readings out of tolerance.
Current relay	Failure of starter button to hold in or time switch to wind.

1st, 2nd, 3rd or 4th stage relays Open circuit at appropriate stage.

If any component is suspected, its operation must be tested individually to confirm its unserviceability. Any unserviceable component must be removed and renewed before the starting switch can be considered serviceable.

Insulation resistance test

11. Test the insulation resistance between the following points, using a 250-V. insulation resistance tester.

Terminal '+' and terminals ST and N and frame

Terminal ST and terminal N and frame

Terminal N and frame

A reading of at least 50,000 ohms should be obtained.

Note . . .

The values of resistances quoted apply to units being tested under normal workshop conditions. Allowance should be made for climatic conditions, in particular humid climates. Under these conditions, resistance readings may be lower and discretion should be exercised before rejecting units.

TABLE I
Times and resistance during cycle

	Time from commencement of first cycle	Reading of ohmmeter in ohms
First stage	0 seconds	1 ±10 per cent
Second stage	2 $\frac{3}{4}$ to 3 $\frac{1}{4}$ seconds	0.15 ±10 per cent
Third stage	7 $\frac{1}{2}$ to 8 $\frac{1}{2}$ seconds	0.05 ±10 per cent
Fourth stage	12 $\frac{1}{2}$ to 13 $\frac{1}{2}$ seconds	0
End of fourth stage	28 to 30 seconds	00
First stage of second cycle	35 to 37 seconds	1 ±10 per cent

This file was downloaded
from the RTFM Library.
Link: www.scottbouch.com/rtfm

Please see site for usage terms,
and more aircraft documents.

