

## Chapter 13

### PUMP, DE-ICING, WELDON TYPE 105B

#### LIST OF CONTENTS

	Para.		Para.
<i>Introduction</i> ... ..	1	<i>Assembling</i> ... ..	
<b>Description</b> ... ..	2	<i>Motor</i> ... ..	10
<i>Operation</i> ... ..	4	<i>Pump</i> ... ..	11
<b>Servicing</b> ... ..	5	<i>Testing</i> ... ..	
<i>Dismantling</i> ... ..	6	<i>Insulation resistance test</i> ... ..	12
<i>Pump</i> ... ..	7	<i>Load test</i> ... ..	13
<i>Motor</i> ... ..	8		

#### LIST OF ILLUSTRATIONS

	Fig.		Fig.
<i>De-icing pump, Weldon Type 105B</i> ... ..	1	<i>Exploded view of motor</i> ... ..	3
<i>Exploded view of pump</i> ... ..	2	<i>Circuit diagram</i> ... ..	4

#### LEADING PARTICULARS

<i>De-icing pump Weldon Type 105B</i> ... ..	Ref. No. 5UE/8497
<i>Rated flow per outlet</i> ... ..	3.6 to 4.8 gal/hour
<i>Voltage</i> ... ..	28V
<i>Current</i> ... ..	1.25A
<i>Minimum brush length</i> ... ..	0.25 in.
<i>Minimum commutator diameter</i> ... ..	0.84375 in.
<i>Depth of mica undercut</i> ... ..	0.03125 in.

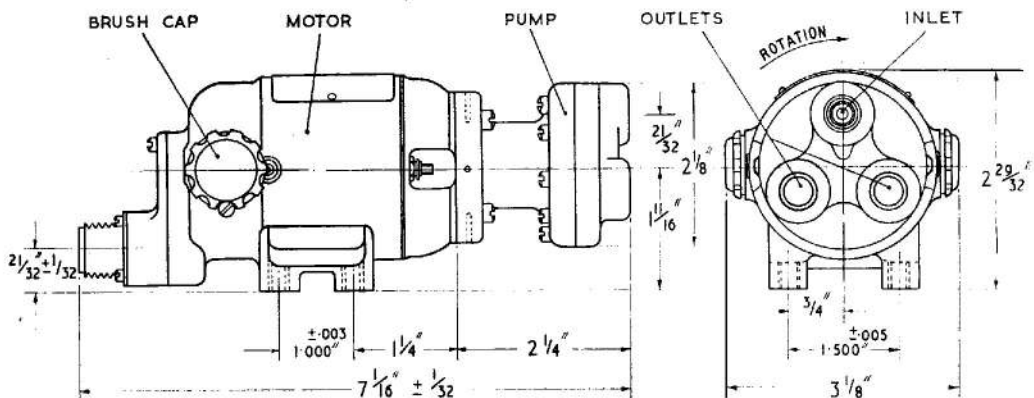

Fig. 1. De-icing pump, Weldon Type 105B

**RESTRICTED**

## Introduction

1. The Weldon de-icing pump type 105B is a cam rotor type pump driven by an electric motor at 12000 rev/min. The unit was designed to pump de-icing fluid at a rate of 3.6 to 4.8 gal/hour from each of its two outlets.

## DESCRIPTION

2. The de-icing pump comprises a 28V d.c. two pole, series wound motor driving a three lobe cam type rotor. The motor is supplied through a single pole plug, the return path being through the motor frame via the negative brush. The armature rotates between two sealed for life ball bearings.

3. The pump comprises a body, rotor and cover. The pump body contains a bronze insert in which the rotor rotates. The insert is slotted at the front to accommodate the blades which rest on the rotor forming dams to deflect the fluid into the outlet holes. The cover contains the inlet port and the two outlet ports. The inlet port is aligned with the drilled hole in the pump body. Leakage of fluid at the rotor shaft is prevented by means of a rotary seal held in position by a spring. The seal assembly consists of a rubber ring fitted inside an alloy steel ring. The steel ring has a lapped face which rotates against the insert, the rubber ring seals the inner diameter of the steel ring around the rotor shaft.

## Operation

4. The rotation of the rotor fig. 2 creates a suction within the pump, causing the fluid to be drawn in through the inlet port. The fluid then flows through the hole in the pump body, filling the reservoir which is the common supply for the feeding holes, one at each blade. The fluid fills the cavities formed by the bore in the insert and the drop of the rotor. The fluid is then conveyed around the circumference of the bore by the rotation of the rotor until it is stopped by the blades, which act as dams. The blades are kept in contact with the rotor by the retaining ring. The fluid is forced through the two outlet holes, one at each blade, by the pressure of the rotating lobes and then out to the two outlet ports.

## SERVICING

5. The pump should be examined at intervals specified in the relevant Servicing

Schedule for signs of external damage, corrosion and leakage of fluid.

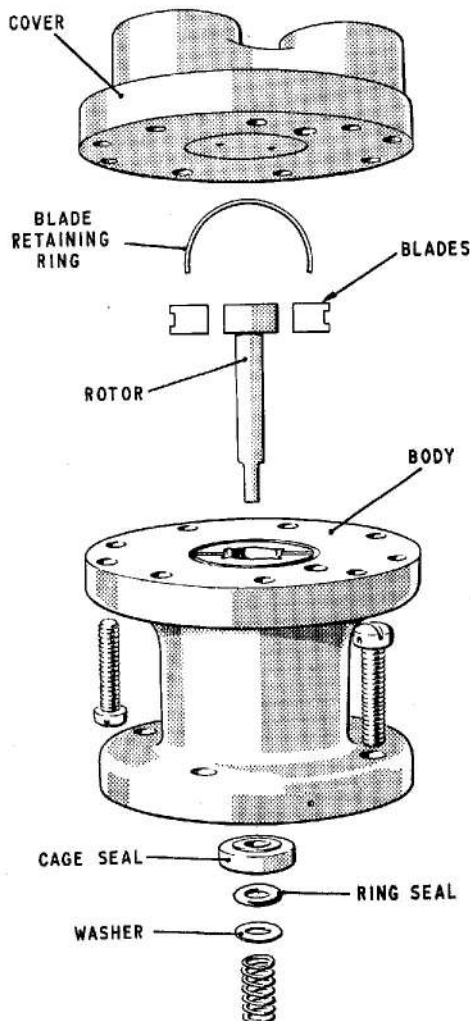

Fig. 2. Exploded view of pump

## Dismantling

6. When it is required to examine or renew an item the pump or motor should be dismantled as described in the following paragraphs until the suspect part is removed.

## Pump

7. Remove the locking wire from the four screws securing the pump to the motor, remove the screws and pump then proceed as follows:—

- (1) Remove the seal spring and washer from the pump rotor shaft.
- (2) Using long nosed thin pliers, remove the cage seal taking care not to damage the bronze seat.

RESTRICTED

- (3) Remove the locking wire from the nine screws securing the cover to the pump body and remove the cover.
- (4) Remove the rotor by pressing on the end of the rotor shaft.
- (5) Collapse the blades towards the centre and remove the blades and retaining ring. Identify each blade so that each blade can be restored to its original slot and position during assembly.

**Motor**

8. Remove the pump from the motor as in para. 7 then proceed as follows:—

- (1) Remove the locking wire and screw securing the brush caps 7.
- (2) Remove the brush cap 7, copper washer 8 and brush holder screw 9 then remove the brushes 10.

- (3) Remove the two screws securing the two brush holders 11 and remove the brush holders.
- (4) Remove the two nuts and washers securing the drive end frame 1 and remove the drive end frame, copper gasket 2 and oil seal 3.
- (5) Remove the four screws securing the plug 19 and remove the plug and gasket 18.
- (6) Remove the two screws securing the hub cap 17 and remove the hub cap, gasket 16 and washers 14 and 15.
- (7) Remove the commutator end frame complete with armature.
- (8) Remove the screw and washer from the end of the armature shaft and remove the armature.
- (9) Remove the bearings.

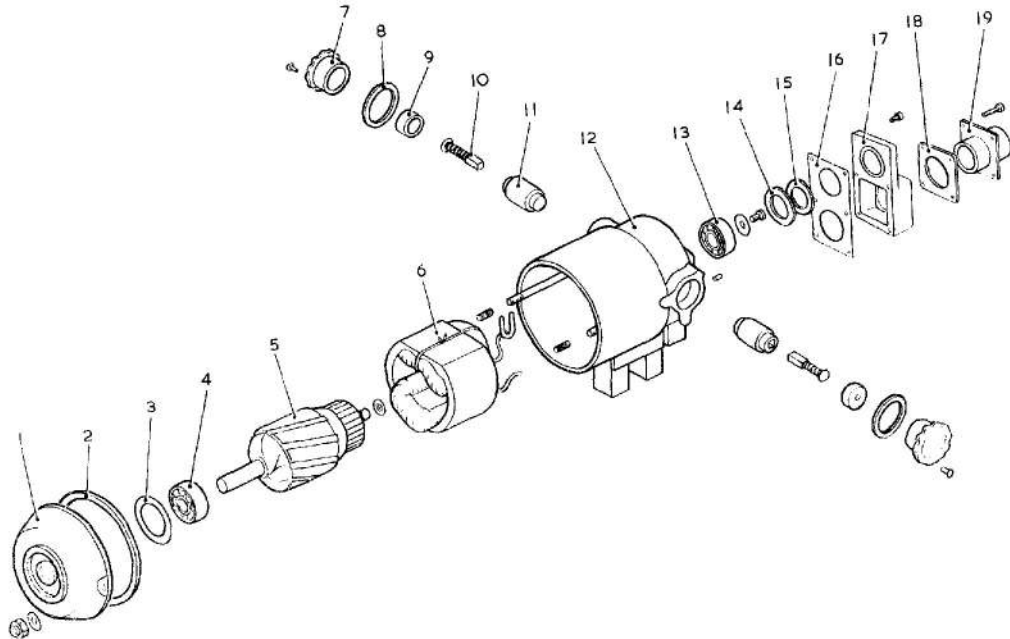

Fig 3. Exploded view of motor

**Key to fig. 3**

- |    |                           |    |                         |
|----|---------------------------|----|-------------------------|
| 1  | END FRAME, DRIVE          | 11 | BRUSH HOLDER            |
| 2  | GASKET, COPPER            | 12 | END FRAME, COMMUTATOR   |
| 3  | SEAL, OIL                 | 13 | BEARING, COMMUTATOR END |
| 4  | BEARING, DRIVE END        | 14 | WASHER                  |
| 5  | ARMATURE                  | 15 | WASHER                  |
| 6  | FIELD COIL                | 16 | GASKET, HUB CAP         |
| 7  | CAP, BRUSH                | 17 | HUB CAP                 |
| 8  | WASHER, COPPER            | 18 | GASKET, PLUG            |
| 9  | SCREW, BRUSH HOLDER       | 19 | PLUG                    |
| 10 | BRUSH AND SPRING ASSEMBLY |    |                         |

**RESTRICTED**

9. The pump and all metallic parts of the motor except the armature, bearings, brushes and field assembly should be cleaned in lead free gasoline. Dirt and foreign matter should be blown from the field assembly using clean, dry compressed air. The armature and inside the field assembly should be cleaned using a clean dry cloth moistened in lead free gasoline.

### Assembling

#### Motor

10. If the bearings have been removed these should be fitted on to the armature shaft taking care to replace any spacing washers previously removed, then proceed as follows:—

- (1) Fit armature 5 into commutator end frame 12 and replace the screw and washer on the end of the armature shaft.
- (2) Fit the commutator end frame, complete with armature on to the yoke.
- (3) Replace the washers 14 and 15, gasket 16 and hub cap 17 securing in position with two screws.
- (4) Reconnect field coil lead to plug pin and fit plug 19 and gasket 18 to hub cap securing in position with the four screws provided.
- (5) Replace oil seal 3 on armature shaft and fit copper gasket 2 and drive end frame 1 to yoke securing in position with the two nuts and washers provided.
- (6) Push brush holders 11 into their sockets and secure them in position using the two grub screws.
- (7) Replace the brushes 10 in their correct holders and secure using the screws 9 provided.
- (8) Replace the copper washers 8 and brush caps 7 securing with the two screws. The two screws should be wire locked.

#### Pump

11. The pump should be assembled in the following order:—

- (1) Replace the blades in the slots and the retaining ring in the groove. Push the blades to the extreme outside and tilt the tops outwards to form a cone to allow easy entrance of the rotor.
- (2) Push the rotor into place. The blades should then assume their normal position.

(3) Examine the tops of the blades and the rotor to ensure that they are 0.004 in. to 0.006 in. below the surface of the body.

(4) Place the cover on the body with the inlet port hole directly over the drilled inlet hole in the body and secure the cover in position using nine screws.

(5) Apply several drops of light grade, clean oil to the inlet port to serve as a lubricant for initial start.

(6) Turn the rotor shaft to ensure it turns freely.

(7) Wire lock the nine screws.

(8) Apply a drop of light grade, clean oil to the seal face of the bronze insert to serve as a lubricant for initial starting.

(9) Fit the rubber sealing ring inside the cage seal and push this assembly on to the rotor shaft.

(10) Place the seal washer then the spring on the rotor shaft. To attach the pump to the motor, engage the end of the rotor shaft with the slot in the armature shaft. Secure the pump and motor together using four screws then wire lock the screws.

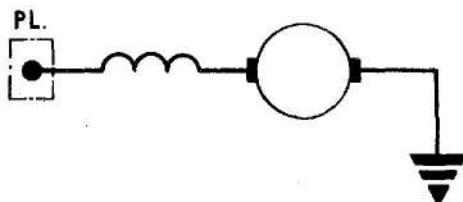

Fig. 4. Circuit diagram

### Testing

#### Insulation resistance test

12. Remove the negative brush and test the insulation resistance between the pin of the plug and the motor frame. A reading of not less than 50,000 ohms should be obtained.

#### Load test

13. If a suitable test rig is available, connect the motor to a 27V d.c. supply and load the motor to a torque of 1.128 oz. in. The current should be 1.1 to 1.4A at a speed of 12,500 to 16,000 rev/min.

**RESTRICTED**

This file was downloaded  
from the RTFM Library.

Link: [www.scottbouch.com/rtfm](http://www.scottbouch.com/rtfm)

Please see site for usage terms,  
and more aircraft documents.

