

## Chapter 8

# PUMP, FUEL, METHANOL/WATER, TYPE FB4, Mk. 1

### LIST OF CHAPTERS

	Para.		Para.
Introduction	1	Operation	17
Description		Installation	18
General	3	Pipe connections	21
Gland	4	Servicing	
Impeller	5	General	22
Vapour guide cone	9	Electrical tests	25
Filter	10	Leakage tests	29
Driving motor	11	Lubrication	30
Gland drain connections	16		

### LIST OF ILLUSTRATIONS

	Fig.		Fig.
General view of methanol/water injection pump, FB4, Mk. 1	1	Sectional view of pump	2

### LEADING PARTICULARS

Pump, fuel, methanol/water injection, FB 4, Mk. 1	Stores Ref. 5UE/4443
Nominal voltage	24 volt d.c.
Nominal current	7 amp.
Delivery rate	100 gallons per hour
Delivery pressure	18 lb. per sq. in.
Breeze plug CZ 76498	Stores Ref. 5X/6720
Weight of pump	5 lb. 4 oz.

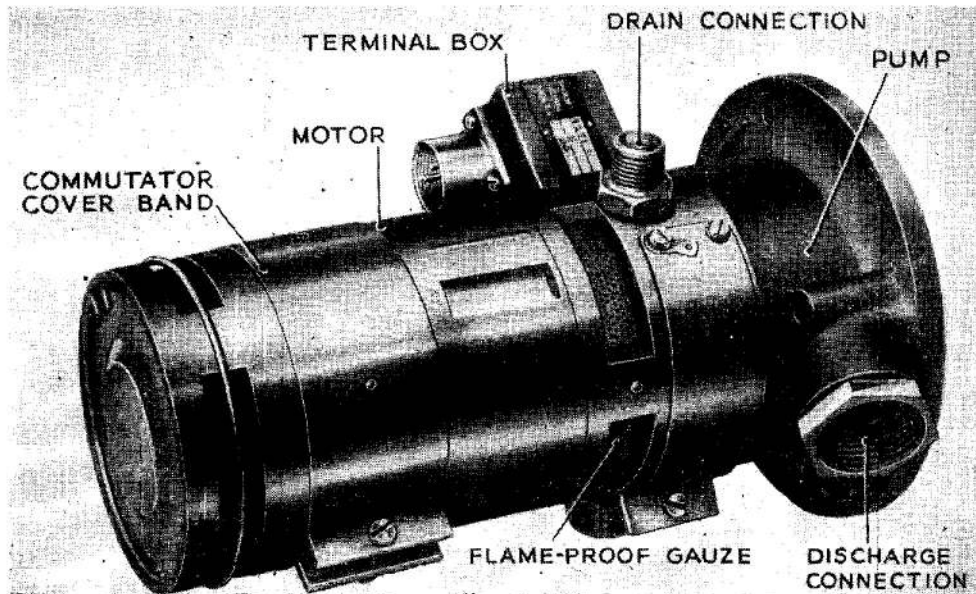

Fig. 1. General view of methanol/water injection pump, FB4, Mk. 1

## Introduction

1. The Type FB4, Mk. 1 methanol/water pump is an electrically driven, impeller type, centrifugal pump, which supplies methanol/water under pressure to the engine during aircraft take-off, by injection into the cylinders, in order to prevent detonation at high boost pressure.

2. This type of pump is designed to deliver 100 gallons per hour at a pressure of 18 lb. per sq. in. when operating on a 24-volt supply and using a maximum current of 7 amp.

## DESCRIPTION

### General

3. The pump casing (*fig. 1*) is a light alloy casting with a suction mounting flange at one end, pierced with light holes, for bolting the pump direct to the wall of the fuel tank. The angular discharge connection embodied in this casing is fitted, with a  $\frac{3}{4}$  in. B.S.P./A.G.S. coupling, tightened against a fibre washer, and locked in position, after installation, with 18 to 22 s.w.g. non-corrodible iron locking wire. The inlet of the impeller projects to accommodate a suction cover. A cork joint is fitted between the cover and the pump casing, the whole being secured by the six nuts and washers holding the pump casing to the motor. A breathing aperture in the side of the case is covered with a fine mesh grid.

### Gland

4. At the end opposite the mounting face, the casing is machined to accommodate a phosphor-bronze gland ring, the inner face of which forms the inner face of the gland. A babbit impregnated carbon-ring, surrounding, and rotating with the impeller hub, is held in contact with the face of the gland ring by a spring held between the impeller and a metal spreader ring. A dome-shaped synthetic rubber gland washer is force-fitted on the hub of the impeller, between the metal housing and the collar, thus forming the flexible drive between the hub of the impeller and the carbon collar working on the face of the phosphor-bronze ring.

### Impeller

5. The impeller is of the single-shrouded, single-entry, end suction type. The heli-coidal-shaped vanes are designed to give maximum efficiency at high altitudes. The impeller is mounted on an extension of the motor shaft by a slotted cone-nut collet

coupling device. This is similar to a chuck in operation, and, when tightened up, grips the driving motor extension shaft.

6. In order to position the impeller on the motor extension shaft correctly on assembly, the coupling is provided with a small shouldered pin passing through a hole bored at right angles to the axis of the shaft.

7. When assembling the impeller over the shaft, the pin passes down any one of the four slots in the impeller hub and snaps into a hole bored at right-angles to the axis of the hub, this assuring correct assembly.

8. To prevent fuel by-passing the gland from the inlet side, the armature shaft extension enters a blind hole in the hub of the impeller. The enclosing shroud on the inlet of the impeller, runs clear of the suction cover with a coarse running clearance in order to reduce pressure leakage between impeller and cover.

### Vapour guide cone

9. Vapour and air when released at high altitudes are liable to be discharged back into the suction space. They are deflected from the inlet of the impeller by a cone shaped deflector (when fitted) its smaller diameter being slightly less than that of the impeller. Two guide vanes, which are integral with the deflector, prevent the formation of a vortex in the suction.

### Filter

10. In order to exclude foreign matter from the pump, the cone is surrounded by a strainer. The clearance between the impeller and the cone (when fitted) must be between 0.011 in. and 0.060 in.

### Driving motor

11. The driving motor is a fan-cooled, flameproof, 2-pole, compound-wound, 24 volt d.c. machine; it employs a minimum of 16 volts for starting, and 22 to 29 volts for running, with an output of approximately 0.10 b.h.p. at 29 volts.

12. The commutator and armature are carried on a shaft running in ball bearings, which are housed in the end-frame, and lubricated with high melting/low freezing point grease.

13. Laminated pole pieces mounted in the bore of the yoke, carry the field windings,

**RESTRICTED**

the yoke and end-frame assembly being held together by through bolts.

14. The commutator end-frame is provided with windows through which the brushes are accessible. The brush boxes are of bakelite. A commutator cover band secured by a nut and screw prevents the ingress of dirt or grease. At this end of the machine the armature shaft is extended to carry a cooling fan. The end of the end-frame is closed by a metal disc secured by a circlip, sprung into a groove machined in the interior of the frame.

15. The driving end-frame carries six studs used for securing the pump casing to a spigot mounting. Gauze covered apertures admit cooling air, which passes over the armature assembly and is exhausted at the Commutator end. The terminal box

is fitted with a 2-pole Breeze plug, size A (Type CZ76498, Stores Ref. 5X/6720). An aperture covered by a cork-lined, hinged cover gives access to the coupling between the motor and pump.

#### Gland drain connections

16. Alternative gland drain connections are provided (*fig. 2*), fitted with  $\frac{1}{4}$  in. B.S.P./AGS couplings, jointed and wired in place. One of these connections is fitted with a blanking cap.

#### OPERATION

17. When the motor is energized its armature shaft rotates. The impeller, being secured by its coupling to the same shaft, also rotates, and accepts methanol/water from the tank, through the inlet in the centre of the mounting flange, and delivers methanol/water through the discharge con-

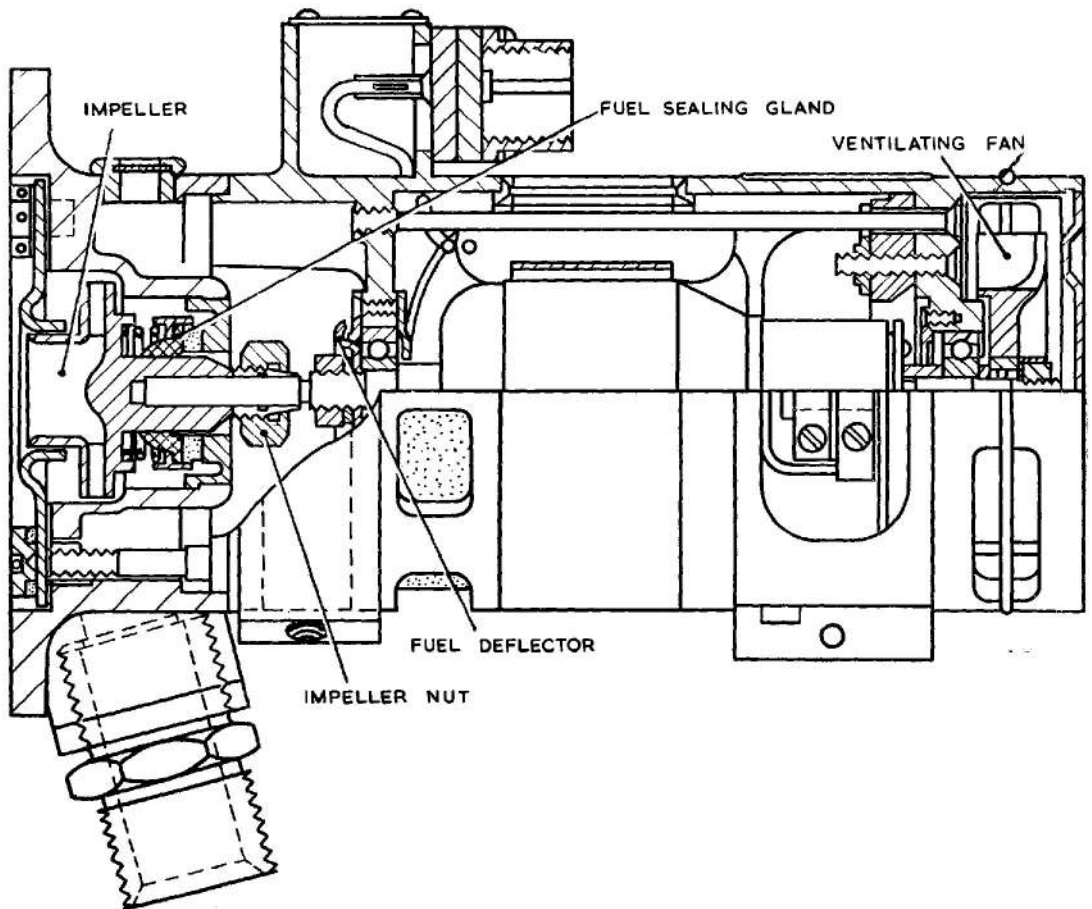

Fig. 2. Sectional view of pump

nection to the inlet side of the engine driven fuel pump, for injection to the cylinders.

### INSTALLATION

18. Before installation ascertain that the pump turns freely by hand, and remove the blanking cap from the  $\frac{1}{4}$  in. drain outlet, which will be in the lower position when the unit is installed in the aircraft. It is important to remember that the blanking cap must be re-fitted to the alternative drain on the opposite side of the pump (fig. 2).

19. Place the pump, flange downwards, in the appropriate fuel, taking care that the fluid does not rise beyond the first joint above the perforated metal breather on the pump casing. This is important, as, if the fuel enters the motor considerable damage may be caused. After soaking for 12 hours, allow the fuel to drain out through the breather.

20. A Langite washer (Stores Ref. 5UE/2538) should be used for the joint between the pump flange and the mounting face of the tank. When necessary, a  $20 \times 20$  mesh gauze strainer embodying an integral vortex eliminator, should be fitted inside the flange mounting. To ensure adequate air circulation for the motor, the tank compartment must be well ventilated.

### Pipe connections

21. In order to prevent vibration causing fractures in the pipes, a short length of rubber tubing should be used when coupling the delivery or outlet, and the lower of the drain connections from the pump. The special  $\frac{3}{4}$  in. BSP./AGS delivery outlet connection is levelled only at the outer end of the bore, and is jointed with an AGS.164A fibre joint washer, at the bottom of the tapped hole in the casing. If it becomes necessary to re-make this connection, it is important that the washer is centralised, or the aperture will be considerably reduced. In the event of damage to the special coupling, it may be replaced with a standard coupling, the new part being jointed between the hexagon shoulder and the outer face of the delivery outlet using an A.G.S.164H fibre joint washer. When the blanking cap is fitted to the unused drain connection, ensure a fuel-tight joint by tightening it against the fibre washer, finally locking with wire.

## SERVICING

### General

22. Store in a cool dry place as heat tends to dry out the lubricant and cause leakage. The unit is supplied ready lubricated, and on no account must it be filled with oil or grease. The glands may leak, as the rubbers have a tendency to dry out or shrink when in store. Soak and swell the rubbers until they are of normal dimensions, as described in para. 19.

23. Do not attempt to run the pump unless the casing is filled with the approved type of fuel.

24. In order to prevent the entry of dust or dirt, blanking plugs should be fitted to all orifices, whenever the pump is completely or partially disconnected.

### Electrical tests

25. The following information is subject to any contrary or over-riding instructions which may be given in the relevant Aircraft Handbook.

26. To make sure that the pump is working properly, during each daily inspection, test as follows:—

- (1) Close all fuel cocks between the pump and the engines, so that no flow can take place.
- (2) Plug a portable ammeter into the ammeter test socket; press the pump test pushes one at a time, and note the current consumption of the pump over a period of not less than 30 seconds.
- (3) If, when not in use, the test socket has its contacts shorted by a plug, Type F (Stores Ref. 5CY/596), the poles of which are electrically connected, it must be removed before the portable ammeter can be plugged in, and the main pump switches must be switched on one at a time for test purposes. Always replace the shorting plug after test or the pumps will remain inoperative.
- (4) The readings of the ammeter are interpreted as follows:—
  - (a) A steady reading of not more than 7 amps.—pump satisfactory.
  - (b) Reading in excess of 7 amps.—pump partially, or completely seized, therefore unserviceable.

RESTRICTED

- (c) Meter pointer oscillates, giving a fluctuating reading — defective gland, inlet shroud of impeller rubbing against suction cover, dirty commutator or sticking brushes.
  - (d) Zero reading—blown fuse, defective switch, defective wiring, or complete electrical breakdown.
- (5) On completion of test, remove the portable ammeter and replace the shorting plug, if this is provided.

**27.** If the result of the foregoing tests is unsatisfactory, a new or re-conditioned pump should be installed, and the faulty one returned to Stores. **PUMPS MUST NOT BE DISMANTLED BY SERVICE UNITS.** In an extreme Emergency, if no replacement is available, the following servicing is permissible, subject to the consent of the officer responsible.

**28.** Where the fault is due to a dirty

commutator, or to sticking brushes, the commutator cover band may be removed and the parts cleaned with a piece of linen. Do not use glass paper or emery paper, or run the pump with the cover band removed, in case sparks from the brushes ignite the fuel. This emergency cleaning is the only servicing permissible; no further attempt should be made to service these pumps.

#### **Leakage tests**

**29.** Examine the drain gland for leakage, and if the rate exceeds 2 drops per minute with the motor at rest, or five drops per minute with the motor running, the pump must be replaced by one drawn from Stores.

#### **Lubrication**

**30.** Before leaving the manufacturer's works the bearings are packed with sufficient grease to last the normal working life of the pump, and no further lubrication should be required.

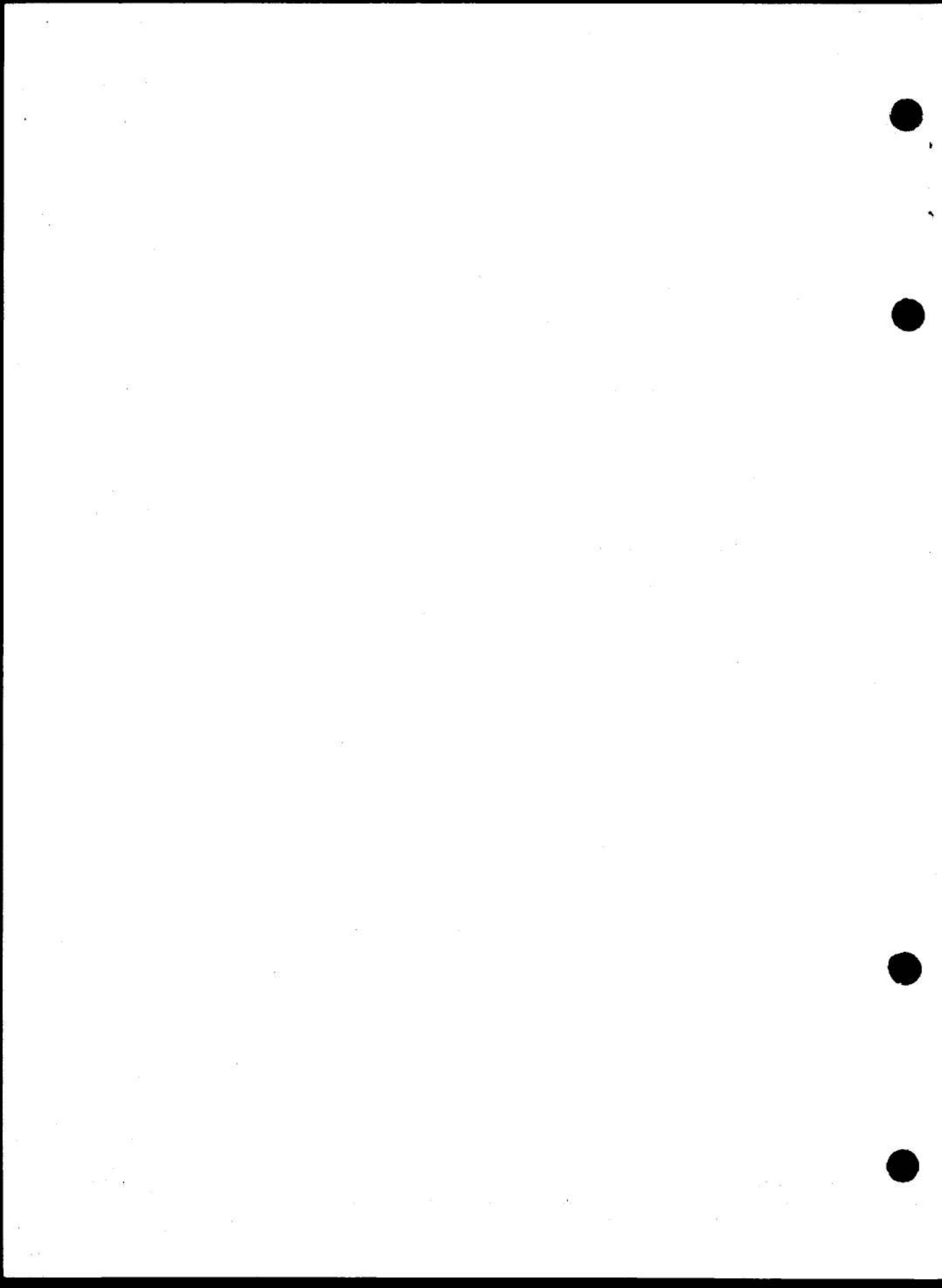

This file was downloaded  
from the RTFM Library.

Link: [www.scottbouch.com/rtfm](http://www.scottbouch.com/rtfm)

Please see site for usage terms,  
and more aircraft documents.

