

## Chapter 1

## ACTUATORS, ROTAX, A0100 SERIES

## LIST OF CONTENTS

	<i>Para.</i>		<i>Para.</i>
<i>Introduction</i> ....	1	<i>Housings and covers</i> ....	11
<b>Description</b> ....	2	<i>Functioning</i> ....	13
<i>Motor</i> ....	3	<b>Servicing</b> ....	16
<i>Brake</i> ....	6	<i>Brushes</i> ....	17
<i>Ram assembly</i> ....	7	<i>Lubrication</i> ....	20
<i>Limit switches</i> ....	8	<i>Insulation resistance test</i> ....	21
<i>Gearbox</i> ....	10	<i>Final check</i> ....	22

## LIST OF ILLUSTRATIONS

	<i>Fig.</i>
<i>Typical A0100 series actuator</i> ....	1
<i>Sectional view</i> ....	2
<i>Typical circuit diagram</i> ....	3

## LIST OF APPENDICES

	<i>App.</i>		<i>App.</i>
<i>Actuator, Rotax, Type A0105/2</i> ....	1	<i>Actuator, Rotax, Type A0113</i> ....	4
<i>Actuator, Rotax, Type A0107</i> ....	2	<i>Actuator, Rotax, Type A0117 and variants</i> ....	5
<i>Actuator, Rotax, Type A0111</i> ....	3		

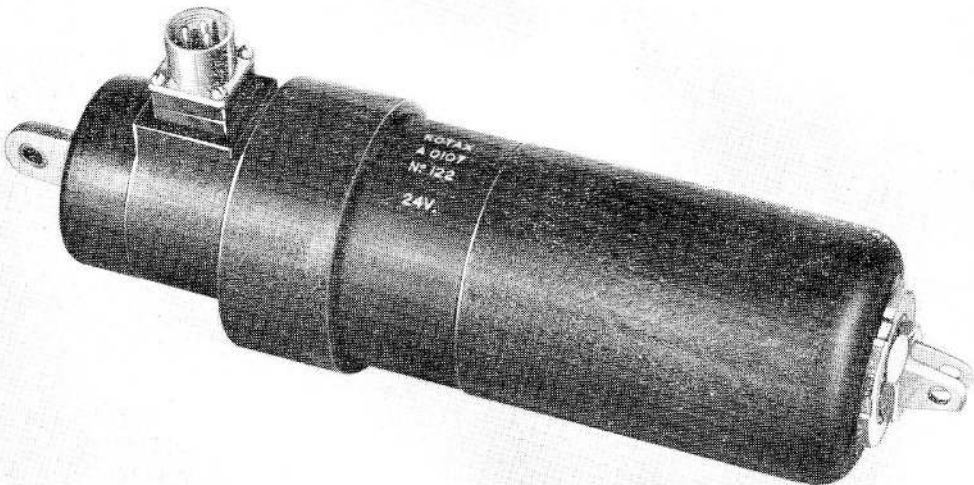

Fig. 1. Typical A0100 series actuator

RESTRICTED

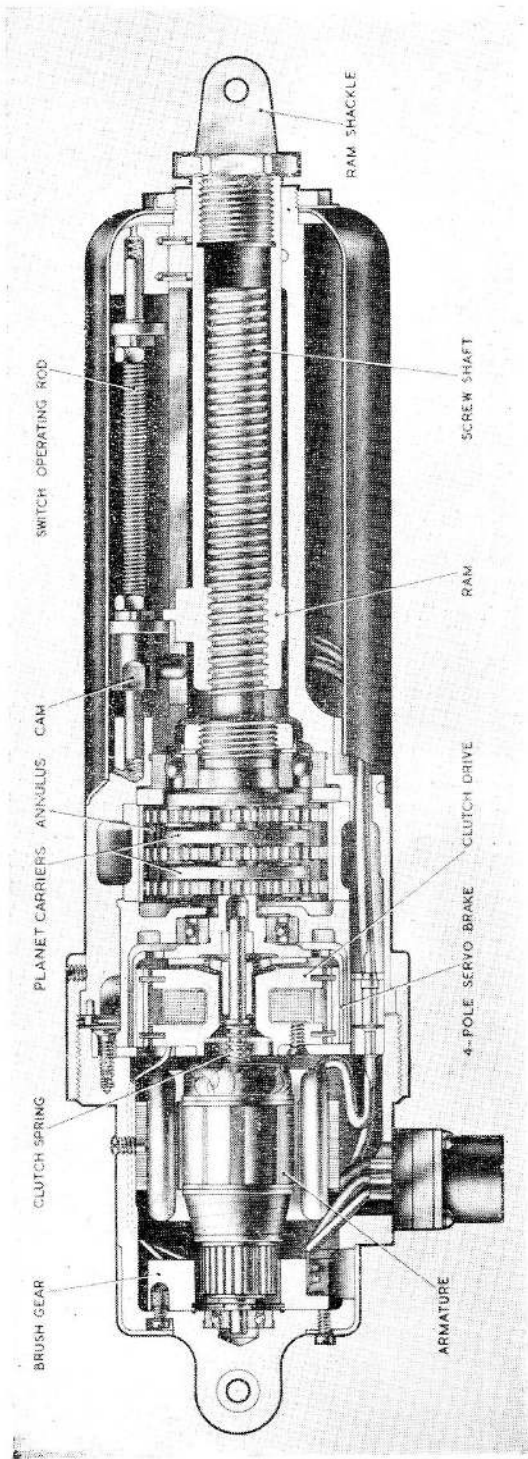

Fig. 2. Sectional view

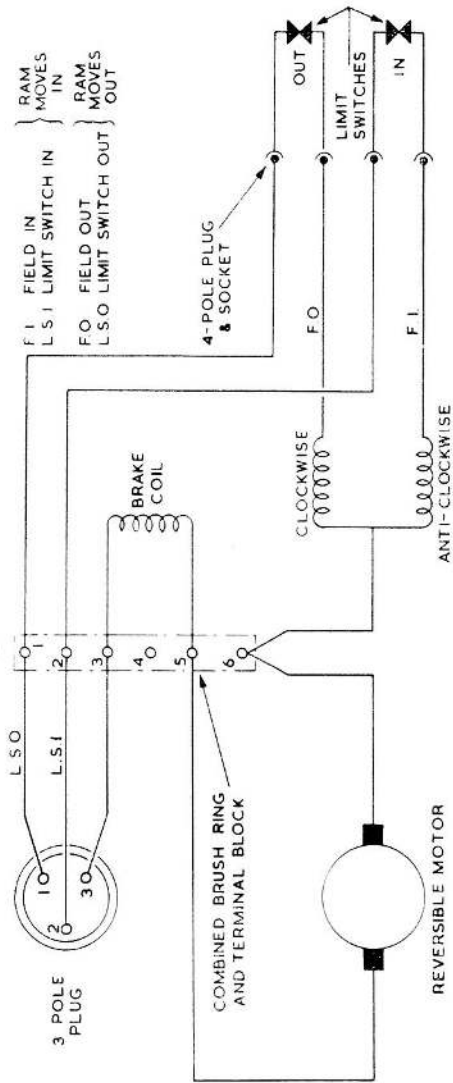

Fig. 3. Typical circuit diagram

### Introduction

1. Linear actuators in the A0100 series follow the general design described in this chapter; specific details of individual types will be found in the appendices to the chapter.

### DESCRIPTION

2. A typical actuator in the series is shown in fig. 1, with a sectional view in fig. 2. The machine is of in-line design, with the motor and ram on the same axis.

#### Motor

3. The actuators are powered by a 4-pole, split-series field motor, rated at 24 volts. A limit switch, connected in series with each of the two pairs of field windings, breaks the motor circuit when the ram reaches the fully extended or fully retracted position.

4. The brush gear assembly is of moulded construction and incorporates a 4-way terminal block. The armature shaft is supported at the commutator end by a ball bearing, and, at the other end, extends through the brake solenoid, being supported in the brake drum by a phosphor-bronze bearing.

5. Mounted on the extension of the armature shaft is a sleeve integral with the clutch plate, and also a spring that holds the clutch plate against the brake drum.

#### Brake

6. A 4-pole electro-magnetic brake is employed, the coil of which is connected in series with the motor. A brake shoe, located on the top of each pair of pole pieces, bears against the inside of the brake drum under the pressure of two springs. The surfaces of the brake shoes are covered with a cork lining, whilst their undersides are plated with copper to prevent the brake sticking, due to residual magnetism, when in the off position.

#### Ram assembly

7. The steel ram is extended or retracted by an internally-meshing screw shaft, which has an acme thread and is integral with the last gear train. The shaft is supported by a ball bearing at the gearbox end. An eyebolt is screwed to the ram and secured by a large locknut.

#### Limit switches

8. The limit switches are mounted in the ram housing and are actuated by a cam on

the switch-operating rod. The ends of the rod are spring-loaded and are carried in circular recesses, one of which is in the ram housing and the other in a bracket at the ram shackle end. Thus, if a suitable pressure is applied, a slight lateral movement of the rod will result; the rod will, however, return to a neutral position when the pressure is removed.

9. At the extreme limits of ram travel a projection of the ram hits a striker nut on the switch-operating rod. This causes the rod to be displaced slightly. Consequently the cam, which is mounted on the switch-operating rod, moves also, and in so doing operates the limit switches.

#### Gearbox

10. Integral with the brake drum, which extends beyond the brake housing into the gearbox, is the first sun gear. The motor drive is transmitted to this gear, and thence, through an annular gear and planetary pinions, to the screwshaft assembly, the last planet train being an integral part of the screw shaft.

#### Housing and covers

11. Secured to the commutator end of the aluminium motor housing is the brush gear cover, which, when removed, allows access to the brush gear and to the moulded terminal block. Also mounted on the motor housing is a 3-pole plug that affords connection to the actuator for the motor supply and limit switch leads.

12. At the gearbox end, the motor housing has an external thread upon which a clamping nut is fitted. This nut secures the ram housing to the motor housing.

#### Functioning

13. With the ram fully retracted, the IN limit switch is open and the OUT limit switch closed. If the supply to the actuator is now switched on, the OUT or EXTEND field of the motor is energized. The solenoid of the brake assembly is also energized and lifts the brake shoes clear of the brake drum, allowing the armature to rotate through the medium of the clutch.

14. As the first sun gear is integral with the brake drum, the motor drive is transmitted through the gearbox components to the screw shaft. This, in turn, extends the

**RESTRICTED**

ram. When the ram reaches the extended position, the cam on the switch rod opens the OUT limit switch, breaking the motor circuit. The IN limit switch is closed simultaneously, and, by moving the external selector switch to the appropriate position, the ram may now be retracted.

15. When the supply is switched off, the brake solenoid is de-energized and the spring-loaded brake shoes bear against, and lock, the brake drum.

### SERVICING

16. These actuators should be serviced in accordance with the general chapter in A.P.4343, Vol. 1, Sect. 17, Chap. 2 and the relevant Servicing Schedule.

#### Brushes

17. Servicing of the electric motor is normally restricted to brush inspection. Brushes should be renewed before they are unduly worn; check that the brushes are a free fit in their boxes and that they are bedded satisfactorily. Check for correct brush spring tension.

18. When inspecting the brushes, remove the three screws securing the motor cover and withdraw the cover over the end coupling to gain access to the brushes.

19. When re-fitting the covers, examine the sealing rings and gaskets; if they are frayed

or damaged they must be renewed. The cover securing screws must be tightened firmly and all other reasonable precautions be taken to prevent the ingress of moisture.

#### Lubrication

20. The actuators are lubricated during manufacture with grease XG-276 and should need no further attention between the appropriate servicing periods.

#### Insulation resistance test

21. The insulation resistance, when measured with a 250-volt insulation resistance tester between all live parts and the frame, should be not less than 0.5 megohm (for R.N.), or 0.05 megohm (for R.A.F.).

#### Final check

22. Ensure that all external nuts, screws, and locking devices are secure. Examine the coupling shackles for security, paying particular attention to the lock-nut on the ram coupling bolt. See that all electrical connections are tight and free from corrosion.

#### Note . . .

*Do not remove the limit switch covers or interfere with the switches. The switches are set to give the correct ram travel within pre-determined limits. If the settings are altered they cannot be re-obtained while the actuator is installed in the aircraft.*

## Appendix 1

### ACTUATOR, ROTAX, TYPE A0105/2

#### LEADING PARTICULARS

<b>Actuator, Type A0105/2</b>	.....	.....	.....	.....	<i>Ref. No. 5W/2</i>
<i>Voltage</i>	.....	.....	.....	.....	28V d.c.
<i>Current (on average working load of 300 lb.)</i>	.....	.....	.....	.....	1.6 amp.
<i>Speed (on load)</i>	.....	.....	.....	.....	5,000 r.p.m.
<i>Ram travel</i>	.....	.....	.....	.....	3 in.
<i>Time of travel</i>	.....	.....	.....	.....	50 sec.
<i>Brush spring pressure</i>	.....	.....	.....	3 to 4 oz. (86 to 113 gm.)	
<i>Brush length (new)</i>	.....	.....	.....	.....	0.390 in.
<i>Brush length (minimum)</i>	.....	.....	.....	.....	0.281 in.
<i>Commutator diameter (new)</i>	.....	.....	.....	0.713 to 0.718 in.	
<i>Commutator diameter (minimum permissible)</i>	.....	.....	.....	.....	0.680 in.
<i>Distance between centres (retracted)</i>	.....	.....	.....	.....	12.030 in.
<i>Diameter</i>	.....	.....	.....	.....	3.125 in.
<i>Weight</i>	.....	.....	.....	.....	5 lb.

1. The actuator, Type A0105/2, is generally similar to that described and illustrated in the main chapter. Electrical connection is made through a 3-pole plug, and the ram travel and working load are as stated in Leading Particulars.

**RESTRICTED**

## Appendix 2

### ACTUATOR, ROTAX, TYPE A0107

#### LEADING PARTICULARS

<i>Actuator, Type A0107</i>	....	....	....	....	<i>Ref. No. 5W/3</i>
<i>Voltage</i>	....	....	....	....	<i>28V d.c.</i>
<i>Current (on average working load of 600 lb.)</i>	....	....	....	....	<i>2.9 amp.</i>
<i>Speed (on load)</i>	....	....	....	....	<i>5,000 r.p.m.</i>
<i>Ram travel</i>	....	....	....	....	<i>1.5 in.</i>
<i>Time of travel</i>	....	....	....	....	<i>25 sec.</i>
<i>Brush spring pressure</i>	....	....	....	<i>3 to 4 oz. (86 to 113 gm.)</i>	
<i>Brush length (new)</i>	....	....	....	....	<i>0.390 in.</i>
<i>Brush length (minimum)</i>	....	....	....	....	<i>0.281 in.</i>
<i>Commutator diameter (new)</i>	....	....	....	<i>0.713 to 0.718 in.</i>	
<i>Commutator diameter (minimum permissible)</i>	....	....	....	....	<i>0.680 in.</i>
<i>Distance between centres (retracted)</i>	....	....	....	....	<i>10.9 in.</i>
<i>Diameter</i>	....	....	....	....	<i>3.125 in.</i>
<i>Weight</i>	....	....	....	....	<i>4 lb. 14 oz.</i>

1. The actuator, Type A0107, is generally similar to that described and illustrated in the main chapter. Electrical connection is made through a 3-pole plug, and the ram travel and working load are as stated in Leading Particulars.

RESTRICTED

### Appendix 3

## ACTUATOR, ROTAX, TYPE A0111

### LEADING PARTICULARS

Actuator, Type A0111	....	....	....	....	Ref. No. 5W/173
Voltage	....	....	....	....	28V d.c.
Current (on average working load of 600 lb.)	....	....	....	....	2.9 amp.
Ram travel	....	....	....	....	1.575 in.
Brush spring pressure	....	....	....	3 to 4 oz. (86 to 113 gm.)	
Brush length (new)	....	....	....	....	0.390 in.
Brush length (minimum)	....	....	....	....	0.281 in.
Commutator diameter (new)	....	....	....	0.713 to 0.718 in.	
Commutator diameter (minimum permissible)	....	....	....	0.680 in.	
Distance between centres (retracted)	....	....	....	10.9 in.	
Diameter	....	....	....	....	3.125 in.
Weight	....	....	....	....	4 lb. 8 oz.

1. The actuator, Type A0111, is generally similar to that described and illustrated in the main chapter. Electrical connection is made through a 4-pole plug (Ref. No. 5X/6006), of which three pins only are used, and the ram travel and working load are as stated in Leading Particulars.

RESTRICTED

## Appendix 4

### ACTUATOR, ROTAX, TYPE A0113

#### LEADING PARTICULARS

Actuator, Type A0113	....	....	....	....	Ref. No. 5W/1109
Voltage	....	....	....	....	28V d.c.
Current (on average working load of 600 lb.)	....	....	....	....	4.3 amp.
Ram travel	....	....	....	....	3 in.
Brush spring pressure	....	....	....	3 to 4 oz. (86 to 113 gm.)	
Brush length (new)	....	....	....	....	0.390 in.
Brush length (minimum)	....	....	....	....	0.281 in.
Commutator diameter (new)	....	....	....	0.713 to 0.718 in.	
Commutator diameter (minimum permissible)	....	....	....	....	0.680 in.
Distance between centres (retracted)	....	....	....	....	12.030 in.
Diameter	....	....	....	....	3.125 in.
Weight	....	....	....	....	4 lb. 14 oz.

1. The actuator, Type A0113, is similar to that described and illustrated in the main chapter. Electrical connection is made through a 4-pole plug (Ref. No. 5X/6006), of which three pins only are used, and the ram travel and working load are as stated in Leading Particulars.

RESTRICTED



This file was downloaded  
from the RTFM Library.

Link: [www.scottbouch.com/rtfm](http://www.scottbouch.com/rtfm)

Please see site for usage terms,  
and more aircraft documents.

