

## Chapter 19

# ACTUATORS, PLESSEY, TYPES CZ53681/1, /2 and /F

### LIST OF CONTENTS

	Para.		Para.
Introduction.....	1	End fittings.....	6
Description.....	3	Installation.....	7
Limit switches.....	4	Servicing.....	8

### TABLE

	Table
Measurements of types available.....	1

### LIST OF ILLUSTRATIONS

	Fig.		Fig.
Alternative positions of rear end fitting on actuators, Types CZ53681/1 and 2.....	1	General view of actuator, Type CZ53681/F, with special front end fitting.....	4
Alternative positions of rear end fitting on actuator, Type CZ53681/F.....	2	View of rear end of actuator, Type CZ53681/F.....	5
General view of actuator, Type CZ53681/1, with plunger extended.....	3	Sectional view of actuator, Type CZ53681/F.....	6
		Wiring diagram of actuators, Types CZ53681/1 and 2.....	7
		Wiring diagram of actuator, Type CZ53681/F.....	8

### LEADING PARTICULARS

#### Stores references

CZ53681/1/A.....	5W/283
CZ53681/1/B.....	5W/281
CZ53681/2/A.....	5W/282
CZ53681/2/C.....	5W/214
CZ53681/2/D.....	5W/216
CZ53681/2/E.....	5W/215
CZ53681/2/F.....	5W/212
CZ53681/F/A.....	5W/213
Voltage.....	24 d.c.
Current consumption (on normal load).....	3 amp.
Maximum load.....	150 lb.
Normal load.....	100 lb.
Travel of plunger.....	Refer to Table 1
Distance between centres.....	Refer to Table 1
Time for full travel (on normal load).....	6 to 7 sec.
Brush spring pressure.....	3.5 to 4.5 oz.
Weight (CZ53681/1 and /2).....	2 lb.
Weight (CZ53681/F).....	2 lb. 8 oz.

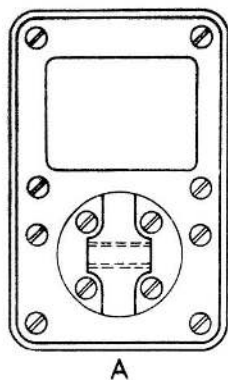

A

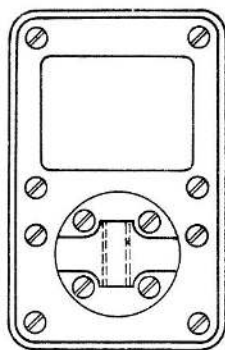

B

Fig. 1. Alternative positions of rear end fitting on actuators, Types CZ53681/1 and /2

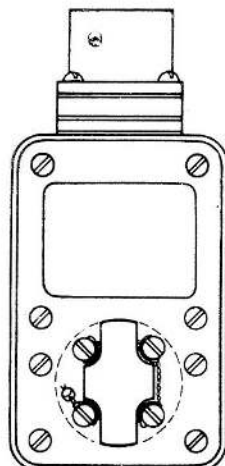

A

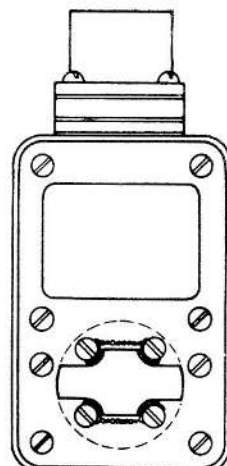

B

Fig. 2. Alternative positions of rear end fitting on actuator, Type CZ53681/F

TABLE I  
Measurements of types available

Type	Position of rear fitting (Ref to fig. 1 & 2)	Length of stroke (in.)	Distance between centres (extended) (in.)*	Distance between centres (retracted) (in.)**
CZ53681/1/A	B	2.83	10.33	7.50
CZ53681/1/B	B	2.3	9.80	7.50
CZ52681/1/C	A	2.94	9.812	6.875
CZ53681/1/D	A	2.5	10.00	7.50
CZ53681/1/E	A	2.83	10.33	7.50
CZ53681/1/F	B	1.5	8.50	7.0
CZ53681/2/A	A	3.0	10.50	7.50
CZ53681/2/B	A	2.8	10.25	7.45
CZ53681/2/C	B	2.0	9.50	7.50
CZ53681/2/D	B	2.93	11.94	9.0
CZ53681/2/E	A	2.0	9.50	7.50
CZ53681/2/F	A	3.0	10.50	7.50
CZ53681/2/G	A	3.0	9.87	6.87
CZ53681/2/H	A	1.50	8.37	6.87
CZ53681/2/J	A	1.75	9.25	7.50
CZ53681/2/Q	A	3.0	11.88	8.88
CZ53681/F/A	A	2.0	9.50	7.50
CZ53681/F/B	B	2.4	9.80	7.40
CZ53681/F/C	A	1.8	9.30	7.50

\*Limits +0.03 in. -0.00 in.    \*\*Limits +0.00 in. -0.03 in.

RESTRICTED

### Introduction

1. The actuators, Types CZ53681/1/2, and /F, belong to the Jaguar series as described in A.P.4343, Vol. 1, Sect. 17, Chap. 2, App. 9. They are used with loads, such as air intakes or fuel cocks, which in their operation require a direct thrust or pull not normally exceeding 100 lb.

2. Reference to Table 1 will show that the large variety of actuators, Type CZ53681, is attributable to variations in the length of stroke and to the position of the rear end fitting. In addition, the position of the connector plug and the type of end fitting may vary. The last three actuators mentioned in the Table, those bearing the suffix /F/-, are fireproof. They have a steel body, whereas the remainder have a body of synthetic compound.

### DESCRIPTION

3. A sectional view of the actuator appears in fig. 6. The general construction is as described in the Appendix on Jaguar actuators, to which reference should be made for further information.

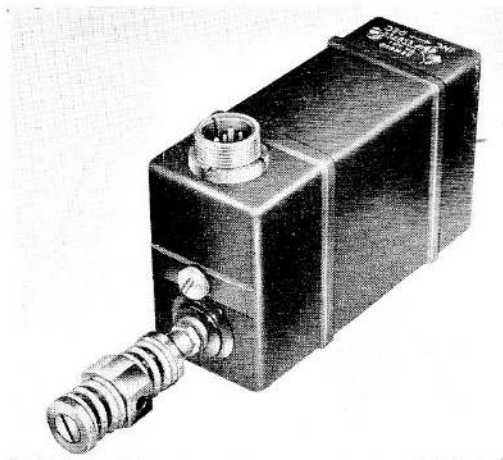

Fig. 4. General view of actuator, Type CZ53681/F, with special front end fitting

F.S./2

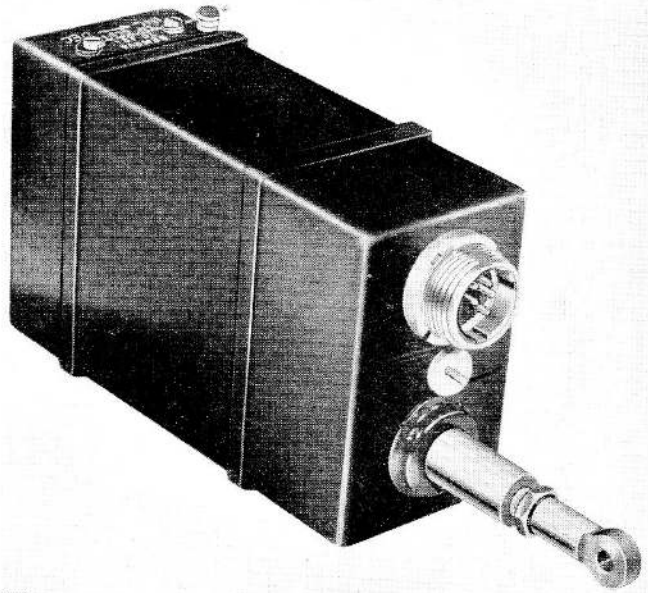

Fig. 3. General view of actuator, Type CZ53681/1 with plunger extended

### Limit switches

4. Two snap-action type limit switches are fitted on opposite sides, and near each end, of the plunger housing to control the extended and retracted positions of the plunger. A single-pole change-over arrangement is provided for a remote indicator lamp, if required.

5. The stroke of the plunger is set to its required length by altering the position of the limit switches. Such action should never be taken, however, without the permission of a competent authority, as a special setting rig is required for the purpose.

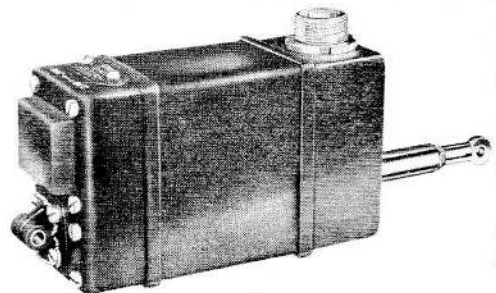

Fig. 5. View of rear end of actuator, Type CZ53681/F

RESTRICTED

(A.L. 1, July 57)

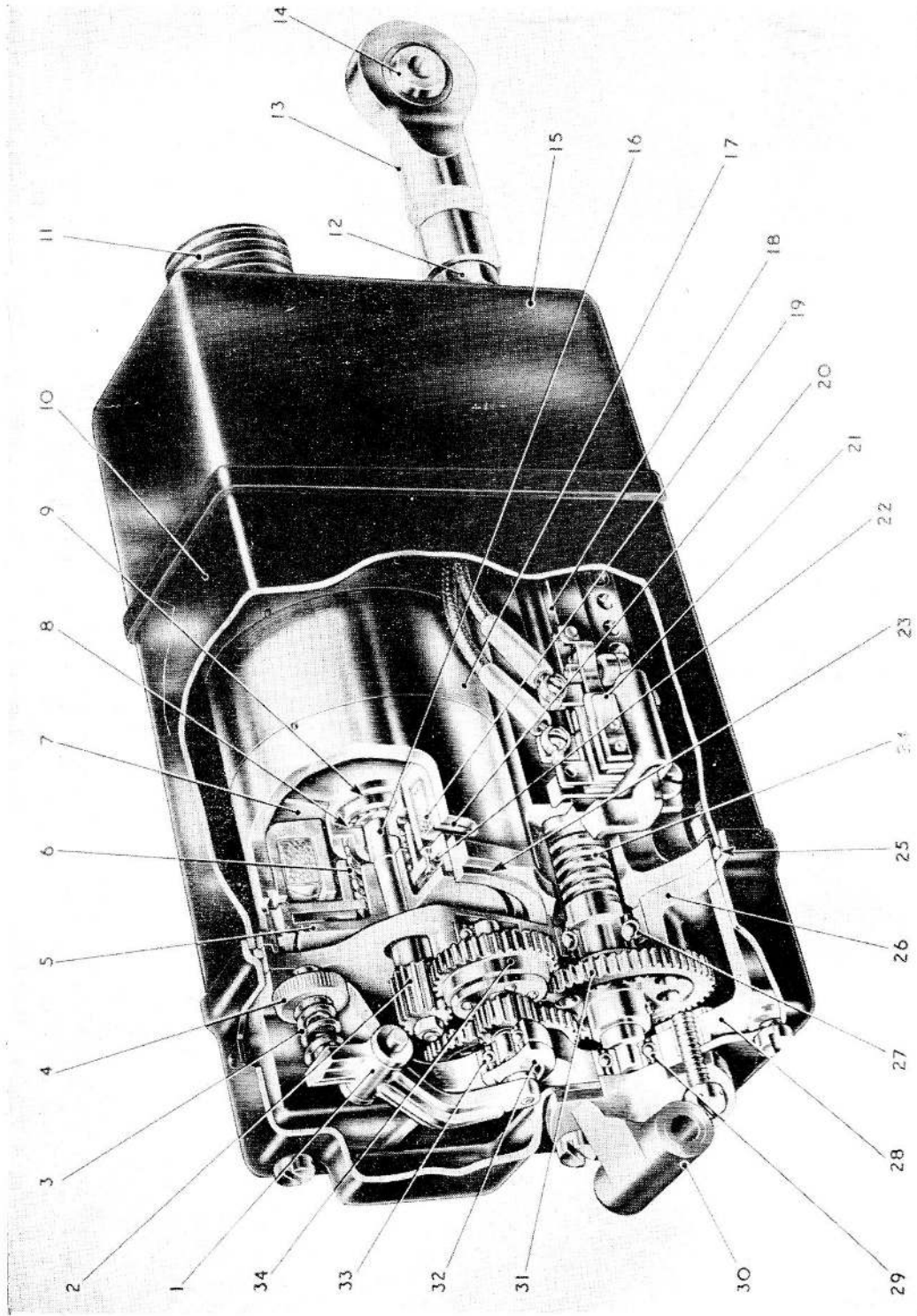

Fig. 6. Sectional view of actuator, Type CZ53681/F

RESTRICTED

**KEY TO FIG. 6**

1 CLUTCH LEVER	13 PLUNGER END FITTING	25 SEALING WASHER
2 FIRST (MOTOR) GEAR	14 SELF-ALIGNING JOINT	26 FRONT COVER (GEARBOX)
3 CLUTCH SPRING	15 FRONT COVER	27 LEAD SCREW BEARING
4 CLUTCH ADJUSTING NUT	16 ARMATURE SHAFT	28 GEARBOX
5 FRICTION PLATE	17 MOTOR	29 FINAL GEAR SPIGOT BEARING
6 BRAKE RETURN SPRING	18 PLUNGER HOUSING	30 END FITTING
7 AIR GAP ADJUSTING SHIM	19 BRAKE COIL	31 FINAL OR LEAD SCREW GEAR
8 SHIM	20 AIR GAP CHECKING SLOT	32 CLUTCH THRUST PAD
9 BRASS CASE	21 "IN" LIMIT SWITCH	33 SPIGOT BEARING
10 SPACER CASE	22 BRAKE SHOE ASSEMBLY	34 SECOND GEAR, CONTAINING CLUTCH
11 MULTI-POLE PLUG	23 MOTOR REGISTER	
12 LOCK-NUT	24 LEAD SCREW	

in order to obtain the accurate adjustment necessary for the correct functioning of the actuator.

**End fittings**

6. The type of end fitting to be used on both the fixed end of the actuator, and the end of the plunger, vary according to the function to be performed by the actuator.

**INSTALLATION**

7. The instructions given in A.P.4343, Vol. 1, for Jaguar actuators are applicable to these actuators.

**SERVICING**

8. The servicing of these actuators is as given for other Jaguar actuators.

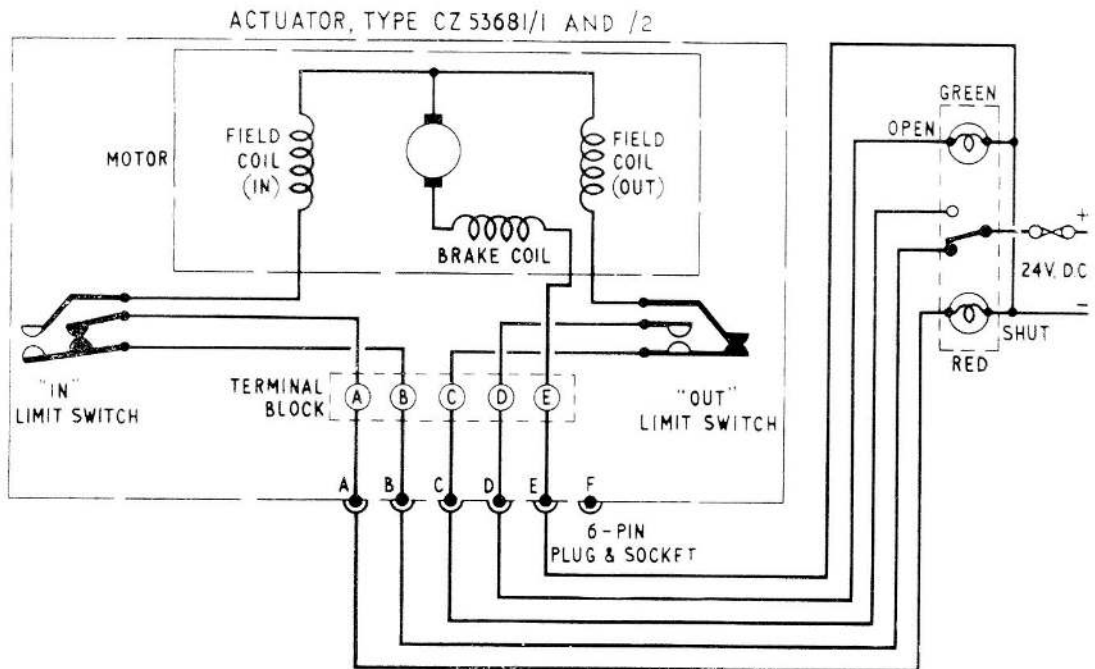

Fig. 7. Wiring diagram of actuators, Types CZ53681/1 and /2

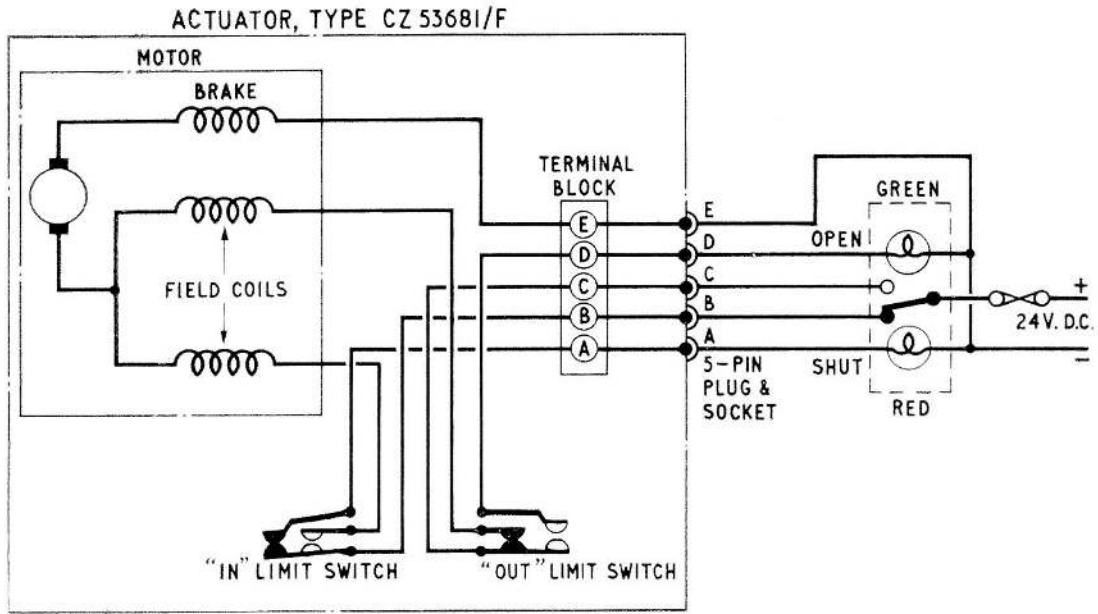

Fig. 8. Wiring diagram of actuator, Type CZ53681/F

RESTRICTED

This file was downloaded  
from the RTFM Library.

Link: [www.scottbouch.com/rtfm](http://www.scottbouch.com/rtfm)

Please see site for usage terms,  
and more aircraft documents.

