

Chapter 25

ACTUATOR, MILES ENG., TYPE MAL-12

LIST OF CONTENTS

	Para.		Para.
<i>Introduction</i>	1	<i>Positive stops</i>	10
Description		<i>Limit and indicator switches</i>	11
<i>General</i>	2	<i>Hand cranking</i>	12
<i>Motors</i>	5	<i>Clutch</i>	15
<i>Reduction gear</i>	6	<i>Ram and crank</i>	16
<i>Differential</i>	9	<i>Wiring</i>	18

LIST OF ILLUSTRATIONS

	Fig.		Fig.
<i>General view of unit</i>	1	<i>Switch box</i>	4
<i>Differential</i>	2	<i>Hand cranking clutch</i>	5
<i>Gearbox</i>	3	<i>Circuit diagram</i>	6

LEADING PARTICULARS

<i>Actuator, Miles Eng., Type MAL 12</i>	<i>Ref. No.</i> 11A/6427
<i>Operating voltage range</i>	18-28.5 Volts d.c.
<i>Stalled current at max. voltage (both motors)</i>	8 amperes
<i>Normal working load</i>	30 lb.
<i>Max. working load at 28 volts</i>	90 lb.
<i>Thrust at 0.050 in. from ends of stroke (28.5V)</i>	210 lb.
<i>Stalling load at max. voltage (mid stroke)</i>	200 lb approx.
<i>Maximum static load</i>	500 lb.
<i>Stroke</i>	1.00 +.00 in. -.02 in.
<i>Overall dimensions</i>	6.0 in. × 3.25 in. × 4.30 in.
<i>Weight</i>	5 lb.
<i>Maximum and minimum time of stroke</i>	0.6 secs. 28 volts both motors 30 lb. load 2 secs. 18 volts, 1 motor, 30 lb. load
<i>Gear ratio and type</i>	Spur gear, with spur gear differential driving cam and roller linear motion. Overall ratio 287: 1
<i>Ambient temperature - range of operation</i>	-60°C to +150°C
<i>Electrical connections</i>	2 Cannon type plugs
<i>Time rating</i>	1 minute
<i>Max. frequency of operation</i>	3 cycles/min.

RESTRICTED

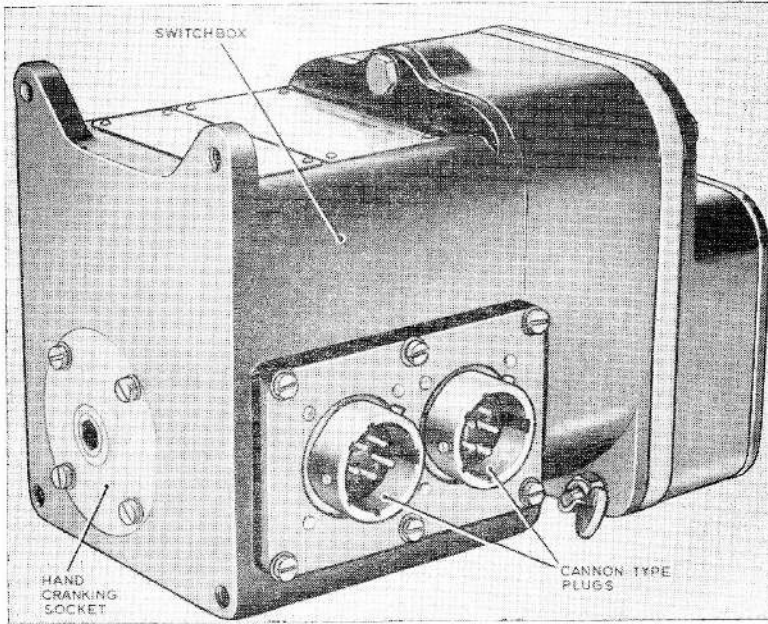

Fig. 1. General view of unit

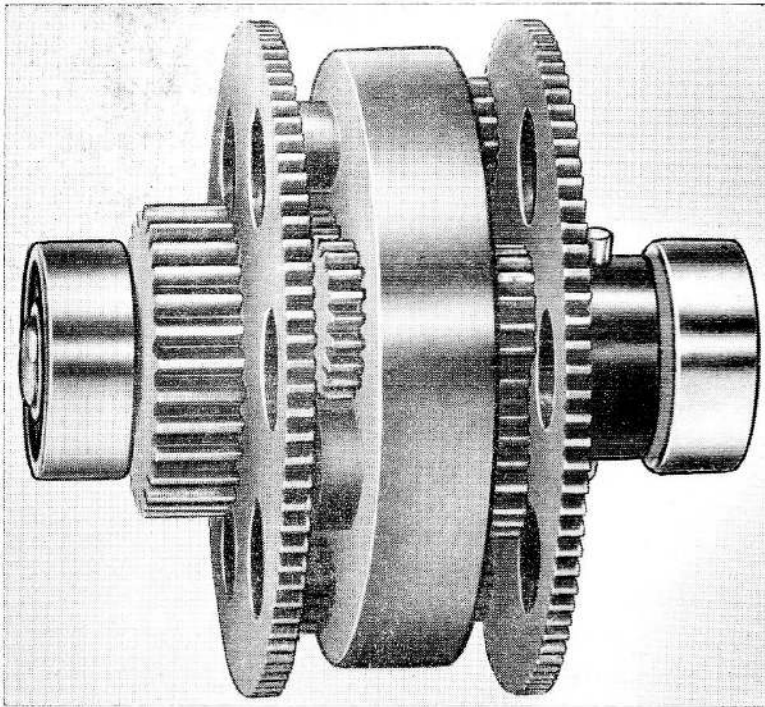

Fig. 2. Differential

RESTRICTED

Introduction

1. The actuator Type MAL 12 (fig. 1) is designed to provide a duplicated electro-mechanical remote controlled system of operation of the "in flight" safety lock on bomb release units. It is intended that a single motor failure will not cause complete failure of the actuator.

DESCRIPTION

General

2. The actuator is driven by two D.C. motors linked mechanically by a differential, and driving a crankshaft, through a reduction gear, and clutch (fig. 3). The crankshaft

operates a cam and roller which converts rotary motion into linear movement on the ram.

3. The motors are controlled by pre-set limit switches, operated by a cam sleeve fitted to the crankshaft. Positive stops are fitted in the gear train to ensure correct positioning of the ram in the event of limit switch failure, or to aid positioning when hand cranking.

4. The ram can be positioned by means of hand cranking, when setting up is required. This is done by means of a detachable key on the end of the actuator.

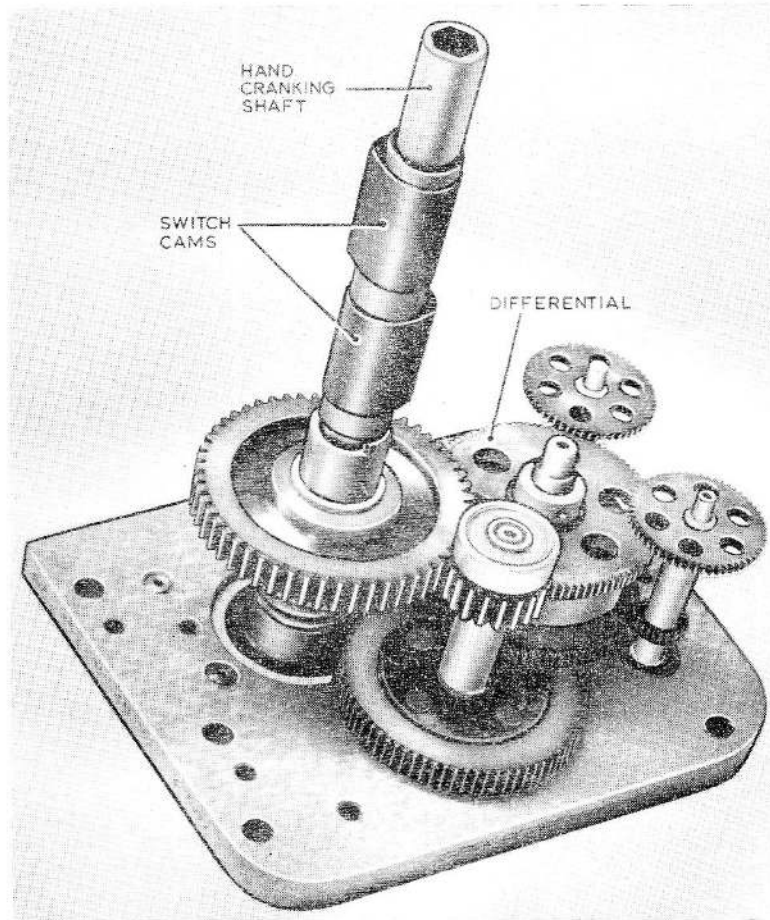

Fig. 3. Gearbox

RESTRICTED

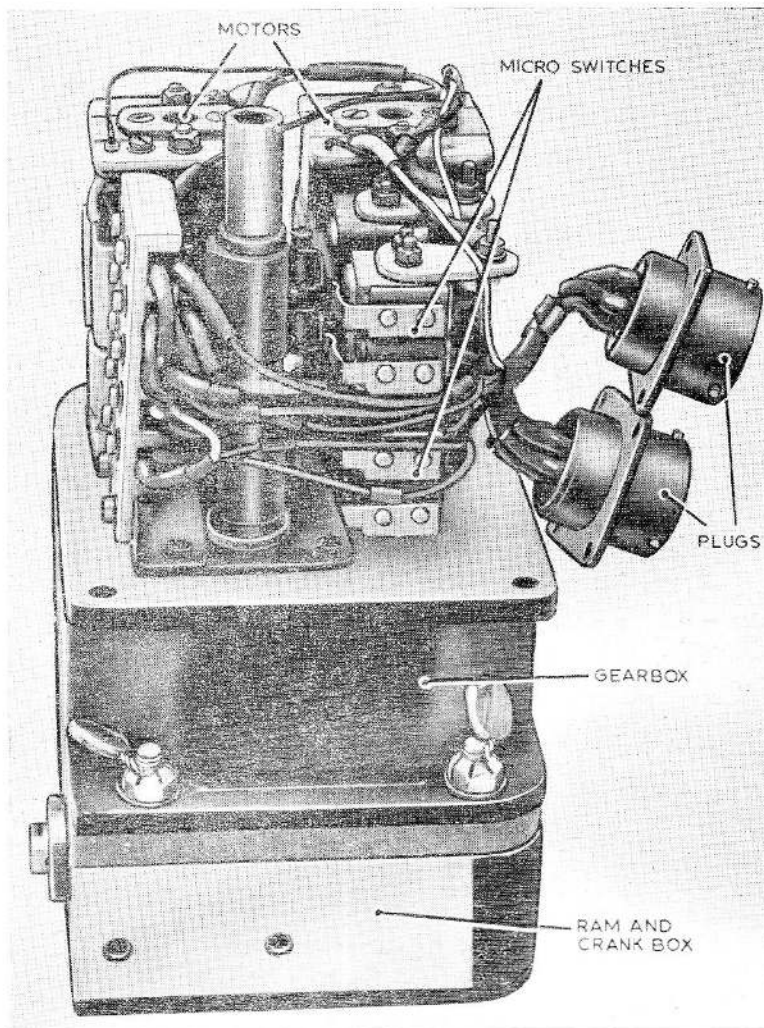

Fig. 4. Switch box

Motors

5. The motors used are of the series wound, split field type (fig. 4). Each motor is fitted with a solenoid operated brake. The brake coil is in series with the motor windings so that when the motor is energized, the brake is disengaged against a spring. When the circuit is broken by the limit switch, or failure in supply, the brake is applied by the spring, thereby locking the armature and its attendant gear train, and so locking one side of differential.

Reduction gear

6. The reduction gear consists of a train of spur gears giving an overall reduction of 287:1, between the motors and crankshaft.

7. Each motor drives one side of the differential, the output from the differential driving further gear reduction to the dog clutch on the crankshaft. The crankshaft operates the ram, the switch cams, and when the clutch is disengaged, it operates the hand cranking mechanism (fig. 3 and fig. 5).

RESTRICTED

8. All shafts are mounted in shielded ball races. The gear train is housed in a cast aluminium alloy housing. The bearings are mounted in one face of the housing, and in an aluminium plate that forms the closing side of box.

Differential

9. The differential is of the spur gear type with three sets of planet wheels rotating about a central sun wheel (fig. 2). The planet wheels are mounted in an aluminium bronze carrier, the sun gears are mounted on the input spur gears, the whole being mounted co-axially on a common shaft. In the event of a motor failing, one side of the differential is locked, and the other motor will drive the actuator with full thrust at half speed.

Positive stops

10. Positive stops are fitted to prevent the ram overrunning if there is a switch failure. These are also used for positioning the ram when hand cranking is used. They are in the form of two studs, a predetermined distance apart, which limit angular movement of the crankshaft (fig. 5).

Limit and indicator switches

11. Limit switches are operated by means of cams situated on the crankshaft. The switches operate to interrupt the supply to the motors, and also to give an indication of the fully extended and retracted position of the ram. They are in two banks of four sealed switches. Two switches, connected in series, operate in each direction of motion (fig. 4).

Hand cranking

12. A hand cranking socket is provided, for positioning the ram, when no electrical supply is available. The hand cranking socket can be found on the end of the crank shaft (fig. 1).

13. When the ram is to be operated by hand cranking it is necessary to insert a suitable key, and push, to disengage the clutch. At the end of the stroke the clutch should be allowed to re-engage under the action of the spring. This should bring the face of the hexagonal socket flush with the face of the boss on the casing.

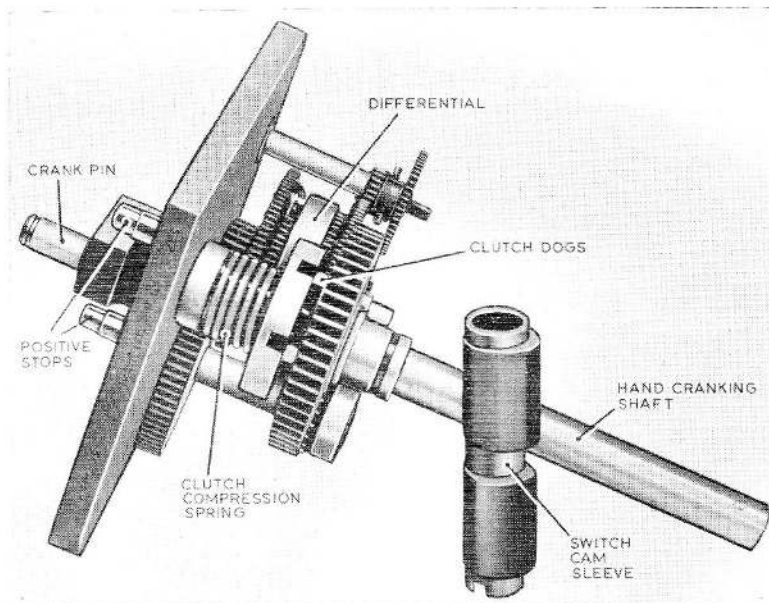

Fig. 5. Hand cranking clutch

RESTRICTED

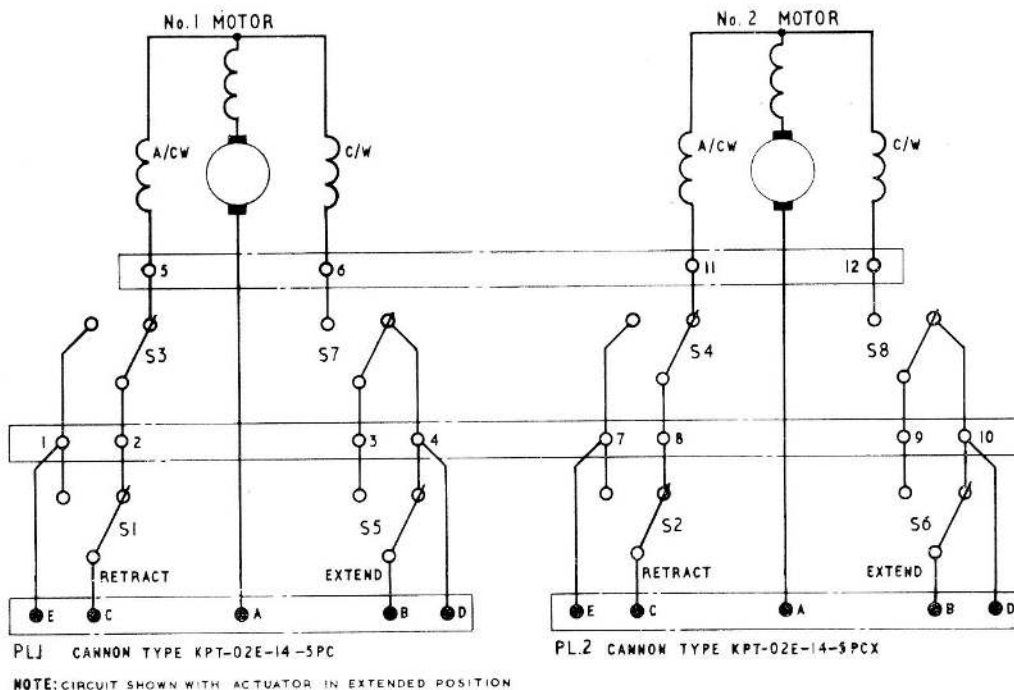

Fig. 6. Circuit diagram

14. Hand cranking should not be used when the ram is in mid stroke, because the clutch will not re-engage properly.

Clutch

15. The clutch is mounted on the crankshaft to enable the ram and camshaft to be moved without moving the motors, when an electrical supply is not available. The clutch plates have four dogs arranged so that the clutch can only re-engage 180° after it has disengaged. The clutch is held in engagement by a compression spring on the crankshaft (fig. 5).

Ram and crank

16. Rotary motion of the crankshaft is converted to linear motion at the ram by means of a crank, fitted with a roller on the crank pin, engaging in a track in the ram. Linear movement of the ram is limited

by means of the positive stops.

17. The cam and roller linear motion develops high thrust at the beginning and end of each stroke. At nominal voltage, and 0.05 in. from each end of the stroke, the thrust is approximately 350 lb. Care should be taken that this does not damage the linkage.

Wiring

18. Wiring in the actuator is single core 19/006 P.T.F.E. insulated cable (fig. 6). Each wire is identified by a numbered marker. Wire terminations at the switches are potted in position, and junctions of two or more wires are made on a terminal block using crimped joints. The actuator wiring is terminated at two 5 pin "Cannon" plugs, types K.P.T.-02E-14-5PC, and K.P.T.-02E-14-SP.CX. The limit switches are of single pole double throw type.

RESTRICTED

This file was downloaded from the RTFM Library.
Link: www.scottbouch.com/rtfm

Please see site for usage terms, and more aircraft documents.

