

Chapter 3 ACTUATORS, ROTAX, A0200 SERIES

LIST OF CONTENTS

	<i>Para.</i>		<i>Para.</i>
<i>Introduction</i>	1	<i>Rear cover assembly</i>	11
Description	2	<i>Functioning</i>	12
<i>Motor and brake</i>	3	Servicing	
<i>Intermediate housing</i>	6	<i>Brushes</i>	14
<i>Ram housing</i>	7	<i>Lubrication</i>	17
<i>Switch and terminal block housing</i>	10	<i>Final check</i>	18

LIST OF ILLUSTRATIONS

	<i>Fig.</i>
<i>Typical actuator, A0200 series</i>	1
<i>Sectional view of typical actuator</i>	2
<i>Typical circuit diagram</i>	3

LIST OF APPENDICES

	<i>App.</i>
<i>Actuator, Rotax, Type A0205/4</i>	1
<i>Actuator, Rotax, Type A0206/2</i>	2
<i>Actuator, Rotax, Type A0215</i>	3
<i>Actuator, Rotax, Type A0216</i>	4
<i>Actuator, Rotax, Type A0217</i>	5
<i>Actuator, Rotax, Type A0220</i>	6

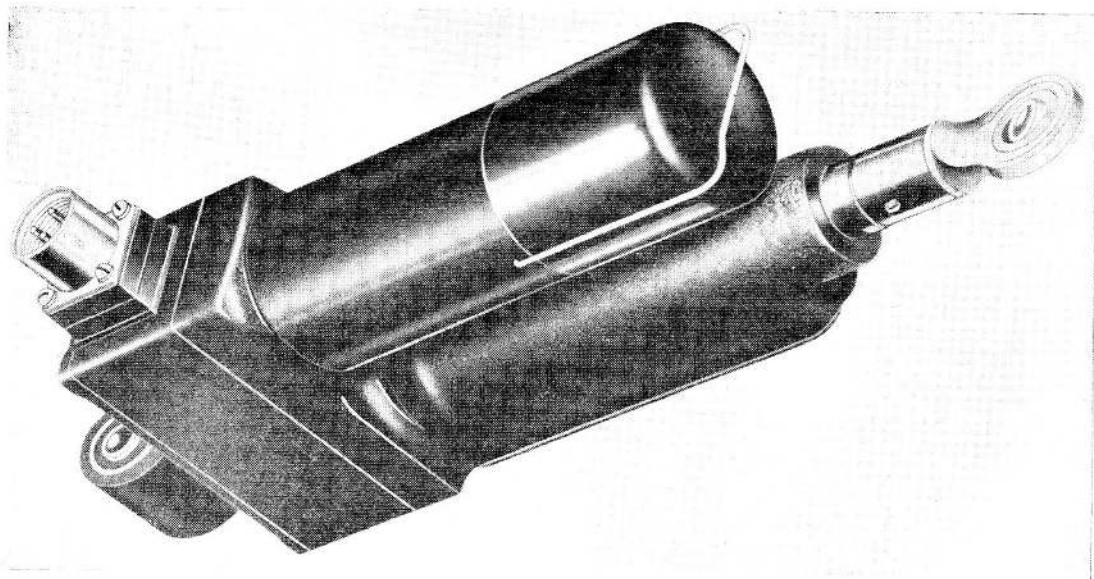

Fig. 1. Typical actuator, A0200 series

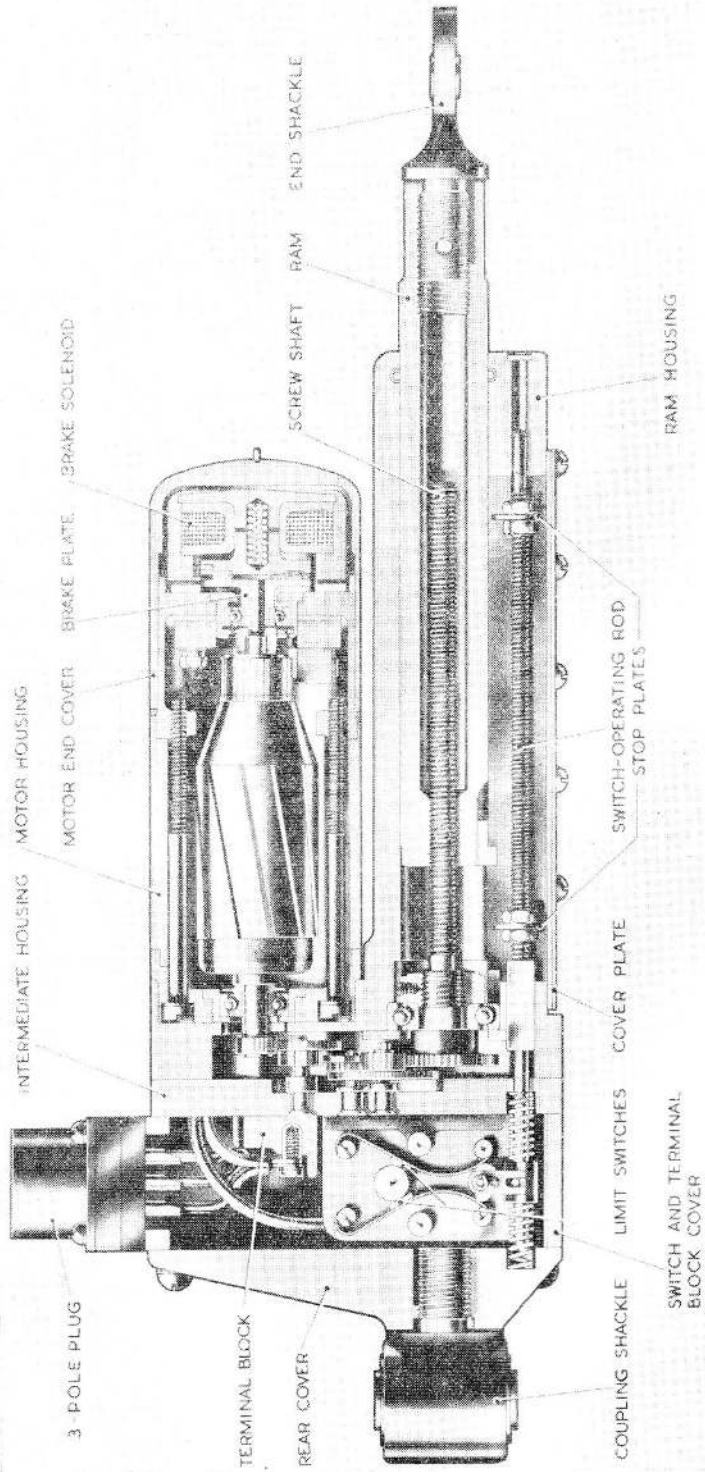

Fig. 2. Sectional view of typical actuator

RESTRICTED

Introduction

1. Rotax linear actuators of the A0200 series follow the general design described in this chapter; a typical actuator is illustrated in fig. 1 and 2, and its circuit diagram is given in fig. 3. Specific details of individual actuators will be found in appendices to this chapter.

DESCRIPTION

2. In these actuators the motor is parallel to and above the ram.

Motor and brake

3. The 24-volt motor used in these actuators is of 2-pole, split-series field design. External electrical connection to the motor is made through a plug mounted on the outside of the switch and terminal cover, and internal connection via a terminal block mounted on the intermediate housing.

4. The motor is secured to the ram housing, in a position parallel to and above the ram, by a centralizing spigot and two bolts. Access to the brush gear is gained by removing the spring-clipped motor end cover.

5. Mounted at the commutator end of the motor is an electro-magnetic brake, the coil of which is connected in series with the armature of the motor. When energized, the coil attracts a central spring-loaded plunger clear of the brake plate upon which it normally bears, so permitting the brake plate to revolve with the armature. De-energizing of the coil will allow the spring to force the plunger against the brake plate, thus, in effect, locking the armature.

Intermediate housing

6. This housing comprises a plate carrying three gears which, with a pinion at the driving end of the armature shaft, form a four-stage spur gear train, with a reduction ratio of 33.64:1. The housing is located at the end of the ram housing by a number of pins, and is secured by the two motor bolts.

Ram housing

7. The ram housing contains a screw and ram assembly, at the outer end of which is fitted a shackle with self-aligning bearing. In the outer surface of the ram, near its inner end, are two pairs of hemispherical holes.

Each pair is in line with a slot that extends along the full length of the housing. Four steel balls operating in these holes and slots prevent the twisting effect of the screw shaft being imparted to the ram during operation.

8. A projection at the extreme inner end of the ram engages with stop plates on the switch-operating rod when the ram reaches the extended or retracted position. The rod and stop plates are accommodated beneath a cover plate, secured to the underside of the ram housing by 10 rd/hd. screws. No adjustment should be made to the stop plates as they govern the length of travel of the ram and are preset by the manufacturers.

9. A gear is machined on the inner end of the screw shaft, the shaft being supported in the housing base by a ball bearing.

Switch and terminal block housing

10. On the opposite side of the intermediate housing to that on which the gears are mounted is assembled a terminal block and a double-acting cam and toggle-operated switch. The switch and terminal block cover is fixed to the intermediate housing by two bolts and locating pins, and, when assembled, forms a deep recess to accommodate the terminal block and switch.

Rear cover assembly

11. Six long, rd/hd. screws that pass through the rear cover, switch cover, and intermediate housing into the ram housing secure the rear cover, attached to the outside of which is a coupling shackle.

Functioning

12. Assuming that the ram is in the extended position, the EXTEND field of the motor will be open-circuited, but a circuit through the RETRACT field will, when the external selector switch is moved to the appropriate position, be completed. The solenoid of the brake assembly is also energized, and the brake lifted clear of the armature plate, permitting free rotation of the armature, which transmits its drive through the gearbox components to retract the ram.

13. As retraction of the ram commences, the projection on the inner end of the ram moves out of contact with the stop plates on the switch operating rod. The rod is then

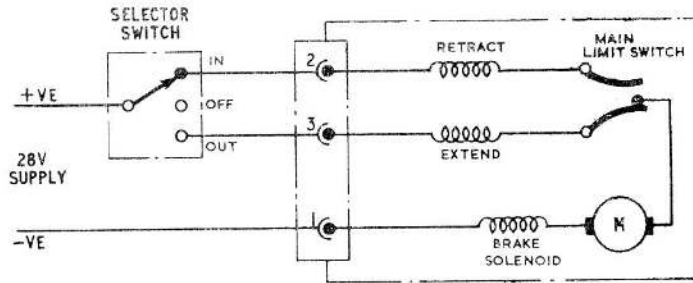

Fig. 3. Typical circuit diagram

returned, by action of the spring, to its previous position. Both limit switches are now made. Thus, if the ram is stopped in any position between the extremities of its travel, it may consequently be moved either towards the extended or retracted position, as desired, by selecting the appropriate position on the external control switch.

SERVICING

Brushes

14. Servicing of the electric motor is normally restricted to brush inspection. Brushes should be renewed before they are unduly worn; check that the brushes are a free fit in their boxes, and that they are bedded satisfactorily. Check for correct brush spring tension.

15. When inspecting the brushes, spring off the retaining clip which secures the end cover of the motor, and remove the cover to gain access to the brushes.

16. When re-fitting the cover, examine the sealing ring and gasket; if they are frayed or

damaged they must be renewed. The cover must be locked in position with the retaining clip, and all other reasonable precautions be taken to prevent the ingress of moisture.

Lubrication

17. The actuators are lubricated during manufacture, and should need no further attention between the appropriate servicing periods.

Final check

18. Ensure that all external nuts, screws and locking devices are secure. Examine the coupling shackles for security and see that the electrical connections are tight and free from corrosion.

Note . . .

No attempt must be made to interfere with the limit switches. They are set to give the correct ram travel, within pre-determined limits. If the settings are altered they cannot be re-obtained while the actuator is installed in the aircraft.

Appendix 1

ACTUATOR, ROTAX, TYPE A0205/4

LIST OF CONTENTS

<i>General information</i>	<i>Para.</i>	Installation	<i>Para.</i>
	1		3

LIST OF ILLUSTRATIONS

<i>Actuator, Type A0205/4</i>	<i>Fig.</i>	<i>Circuit diagram</i>	<i>Fig.</i>
	1		2

LEADING PARTICULARS

<i>Actuator Type A.0205/4</i>	<i>Ref. No.</i> 5W/170
<i>Voltage range</i>	22—29 volts d.c.
<i>Nominal voltage</i>	24V d.c.
<i>Maximum load</i>	160 lb.
<i>Nominal load</i>	80 lb.
<i>Current load (max.)</i>	4.9 amperes
<i>Current</i>	3.5 amperes
<i>Maximum static load</i>	500 lb.
<i>Rating</i>	10 cycles
<i>Temperature range</i>	—40 deg. C. to +90 deg. C.
<i>Weight</i>	2 lb. 9 oz.
<i>Electrical connections</i>	4-Pole plug (Ref. No. 4 Pin 5X/6006)
<i>Maximum altitude</i>	50,000 ft.

	<i>A.0205/4</i>	<i>A.0205/4A</i>	<i>A.0205/4B</i>	<i>A.0205/4C</i>
<i>Travel</i>	3.00 in.	1.900 in.	1.700 in.	1.850 in.
<i>Time of travel</i>	8 sec.	5.00 sec.	4.50 sec.	5.00 sec.
<i>Ram extensions</i>	13.750 in.	12.650 in.	12.450 in.	12.600 in.
<i>Ram retracted</i>	10.750 in.	10.750 in.	10.750 in.	10.750 in.

RESTRICTED

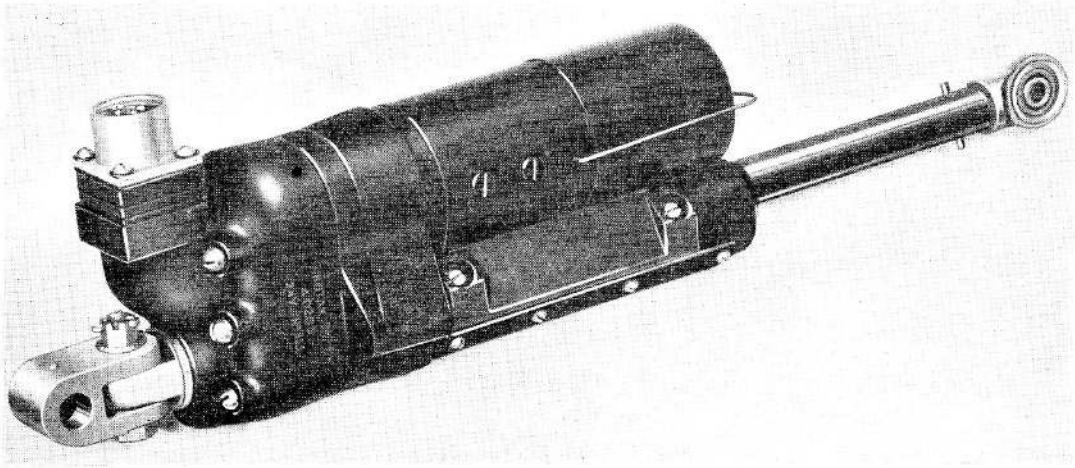

Fig. 1. Actuator Type A0205/4

General information

1. The A.0205/4 Actuator now supersedes all previous units of the A.0205 variants, i.e., A.0205/1, A.0205/2 and A.0205/3. The /4 units are fully tropicalised. A general description of actuators in the A0200 series will be found in the main chapter. The actuator, Type A0205/4 (fig. 1) follows the same general construction; it has, however, a different end cover and shackle assembly which also forms the switch cover.

Note . . .

Suffix letters A, B and C, to the unit code identify the ram extensions and the length of travel.

2. This actuator also differs from most others in the A0200 series in that it has a mid-way limit switch fitted in the ram housing. A small groove, with a step at the extreme inner end, is machined down the full length of the ram, forming the recess in which the plunger of the limit switch rests. When the ram reaches the mid-way position, the step lifts the plunger, thereby breaking the switch circuit and stopping the motor.

INSTALLATION

3. The circuit diagram (fig. 2) is primarily for the actuator alone. For details of the wiring for a particular installation, reference should be made to the relevant Aircraft Handbook.

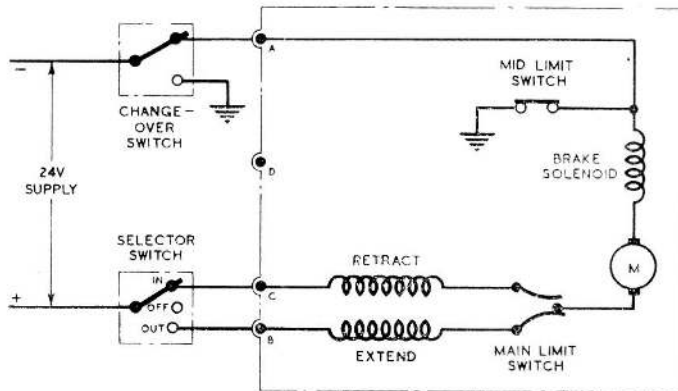

Fig. 2. Circuit diagram

RESTRICTED

Appendix 2

ACTUATOR, ROTAX, TYPE A0206/2

LEADING PARTICULARS

<i>Actuator, Type A0206/2</i>	<i>Ref. No. 5W/5</i>
<i>Voltage</i>	24
<i>Current (on average working load of 80 lb.)</i>	1.7 amp.
<i>Speed (on load)</i>	7,500 r.p.m.
<i>Length of travel</i>	3 in.
<i>Time of travel</i>	14 sec.
<i>Distance between centres (retracted)</i>	9.281 in.
<i>Diameter</i>	4 $\frac{1}{4}$ in.
<i>Brush spring pressure</i>	2 $\frac{1}{2}$ —3 $\frac{1}{2}$ oz.
<i>Minimum brush length</i>	0.2 in.
<i>Weight</i>	2 lb. 13 oz.

1. A general description of actuators in the A0200 series will be found in the main chapter. The actuator, Type A0206/2

follows the same general construction, with the exception that both end shackles are turned through 90 deg.

Appendix 3

ACTUATOR, ROTAX, TYPE A0215

LIST OF ILLUSTRATIONS

	<i>Fig.</i>
<i>Circuit diagram, actuator, Type A0215</i>	1

LEADING PARTICULARS

<i>Actuator, Type A0215</i>	<i>Ref. No. 5W/171</i>
<i>Average working load</i>	80 lb.
<i>Voltage</i>	24
<i>Current (on load of 80 lb.)</i>	1.66 amp.
<i>Travel</i>	3 in.
<i>Time of travel</i>	14 sec.
<i>Brush spring pressure</i>	2½ to 3½ oz.
<i>Minimum brush length</i>	0.2 in.
<i>Weight</i>	2 lb. 13 oz.

1. A general description of actuators in the A0200 series will be found in the main chapter. The actuator, Type A0215, follows the same general construction, with the exception that both end shackles are turned through 90 deg. and its electrical supply connection is made through a 4-pole plug (Ref. No. 5X/6006).

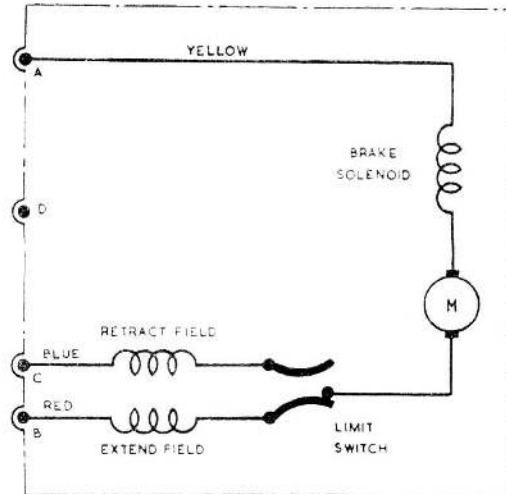

Fig. 1. Circuit diagram, actuator, Type A0215

RESTRICTED

Appendix 4

ACTUATOR, ROTAX, TYPE A0216

LIST OF ILLUSTRATIONS

Fig.

Circuit diagram, Type A0216 actuator 1

LEADING PARTICULARS

Actuator, Type A0216	Ref. No. 5W/294
Average working load	80 lb.
Volts	24
Current (on load of 80 lb.)	1.66 amp.
Travel	3 in.
Time of travel	14 sec.
Brush spring pressure	2½ to 3½ oz.
Minimum brush length	0.2 in.
Weight	2 lb. 13 oz.

1. A general description of actuators in the A0200 series will be found in the main chapter. The actuator, Type A0216, follows the same general construction, with the exception that its electrical supply connection is made through a 4-pole plug (Ref. No. 5X/6006).

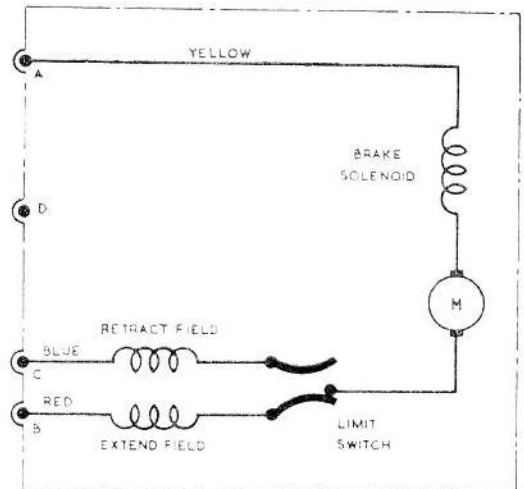

Fig. 1. Circuit diagram, Type A0216 actuator

Appendix 5

ACTUATOR, ROTAX, TYPE A0217

LIST OF ILLUSTRATIONS

	<i>Fig.</i>
<i>Circuit diagram, Type A0217 actuator</i>	1

LEADING PARTICULARS

	<i>Ref. No.</i>
<i>Actuator, Type A0217</i>	<i>24V d.c.</i>
<i>Voltage</i>	<i>80 lb.</i>
<i>Average working load</i>	<i>160 lb.</i>
<i>Maximum working load</i>	<i>500 lb.</i>
<i>Maximum factored load</i>	<i>85 watt.</i>
<i>Input on average load</i>	<i>3 in.</i>
<i>Length of stroke</i>	<i>.050 in.</i>
<i>Maximum overrun</i>	<i>10.000 in.</i>
<i>Length between shackle fixing centres (retracted)</i>	<i>4-pole, 7 amp. breezplug</i>
<i>Electrical connection</i>	<i>2 lb. 8 oz.</i>
<i>Weight</i>	

1. A general description of actuators in the A0200 series will be found in the main chapter. The actuator, Type A0217, follows the same general construction, with the exception that the coupling shackle is turned through 90 deg. and its electrical supply connection is made through a 4-pole plug (Ref. No. 5X/6006).

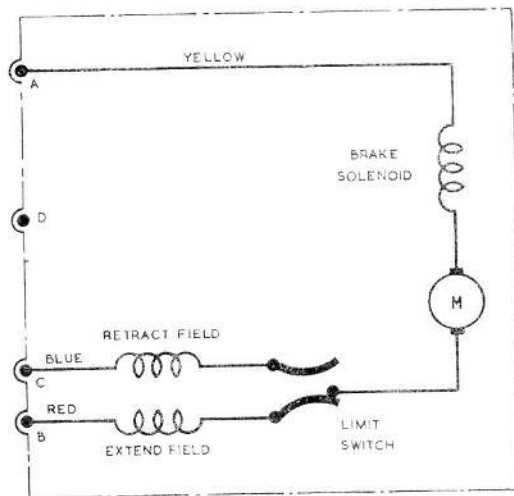

Fig. 1. Circuit diagram, Type A0217 actuator

RESTRICTED

Appendix 6

ACTUATOR, ROTAX, TYPE A0220

LIST OF ILLUSTRATIONS

Fig.
Circuit diagram, Type A0220 actuator 1

LEADING PARTICULARS

Actuator, Type A0220	Ref. No. 5W/688
Voltage	24V d.c.
Average working load	80 lb.
Maximum working load	160 lb.
Maximum factored load	500 lb.
Input on average load	85 watts
◀ Length of stroke	Adjustable between 2.76 in. and 3.010 in. ▶
Maximum overrun	0.050 in.
Length between shackle fixing centres (retracted)	10.000 in.
Weight	2 lb. 8 oz.

1. A general description of actuators in the A0200 series will be found in the main chapter. The actuator, Type A0220, follows the same general construction, with the exception that the coupling shackle is turned through 90 deg. and the ram shackle is adjustable by screwing in or out of the ram. The ram shackle must be firmly secured by the locking nut before the actuator is installed. The electrical supply connection is made through a 4-pole plug (Ref. No. 5X/6006).

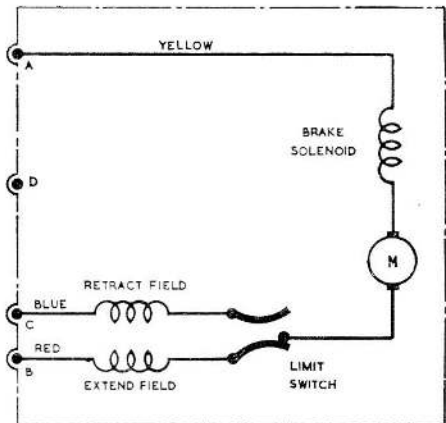

Fig. 1. Circuit diagram, Type A0220 actuator

RESTRICTED

This file was downloaded
from the RTFM Library.

Link: www.scottbouch.com/rtfm

Please see site for usage terms,
and more aircraft documents.

