

## Chapter 32

### ACTUATORS, PLESSEY, 500/1/00257, RATIONALISED

#### JAGUAR SERIES

##### LIST OF CONTENTS

	<i>Para.</i>		<i>Para.</i>
<i>Introduction</i> ... ..	1	<i>End fittings</i> ... ..	28
<b>Description</b>		<i>Covers and gaskets</i> ... ..	30
<i>General</i> ... ..	4	<b>Operation</b> ... ..	32
<i>Motor</i> ... ..	5	<b>Installation</b> ... ..	38
<i>Gearbox</i> ... ..	9	<b>Servicing</b>	
<i>Gears and clutch</i> ... ..	10	<i>General</i> ... ..	41
<i>Leadscrew, plunger and final drive gear</i>	14	<i>Dismantling</i> ... ..	43
<i>Main body</i> ... ..	17	<i>Brushgear</i> ... ..	44
<i>Limit switch assemblies</i> ... ..	18	<i>Lubrication</i> ... ..	47
<i>Switch operating mechanisms</i> ... ..	21	<i>Re-assembling the actuator</i> ... ..	48
<i>Mechanical stops</i> ... ..	24	<i>Testing</i> ... ..	49
<i>Plug assembly and adapter</i> ... ..	26		

##### LIST OF ILLUSTRATIONS

	<i>Fig.</i>		<i>Fig.</i>
<i>General view of actuator</i> ... ..	1	<i>Sectioned view of sixth gear assembly</i>	4
<i>Sectioned view of actuator</i> ... ..	2	<i>Switch operating mechanism</i> ... ..	5
<i>Circuit diagram</i> ... ..	3	<i>Installation diagram</i> ... ..	6

##### LIST OF APPENDICES

	<i>App.</i>
<i>Standard Serviceability Tests for Type</i> 500/1/00257/300 ... ..	A
<i>Actuator, Plessey, Type 500/1/00257/ 300 ... ..</i>	I

#### Introduction

1. The Rationalised Jaguar series of actuators are electro-mechanical machines designed for applications where remotely-controlled linear thrust and pull are required. Fig. 1 is a general view of an actuator in the series.

2. The actuators in this series are divided into three classes, according to performance, and identified by a range of stroke numbers suffixed to the basic part number 500/1/00257. Performance is established by employing one of the three gearboxes available for the series. The components of the gearboxes are identical, variations in their

**RESTRICTED**

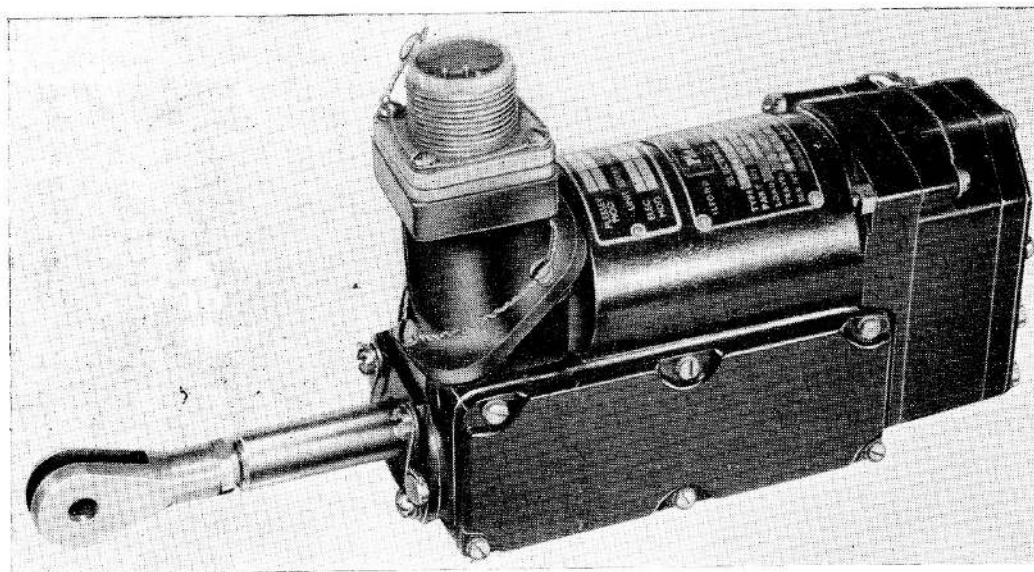

**Fig. 1. General view of actuator**

ratios being effected by assembling the gears so as to vary their juxtaposition in the train transmitting the drive from the motor to the leadscrew.

**3.** Individual variations for actuators in each range relate to the plunger stroke, the extended and retracted centres or dimensions, the type and position of the end fittings and the position of the electrical plug. Details of these features are given in appendices to this chapter. All actuators are resistant to Skydrol 500 fluid.

## DESCRIPTION

### General

**4.** A sectional view of an actuator is shown in fig. 2.

### Motor

**5.** The motor is of the series-wound, split-field type designed for reversible operation from a 18-29V d.c. supply. A brake is built into the motor to effect rapid retardation when the motor power supply is interrupted and to lock the motor when it is at rest; it is electro-magnetically released when the motor is energized.

**6.** The motor armature is supported in ball bearings fitted in end housings between which is interposed a magnet assembly which carries the field coils and encircles the armature. The brake unit is mounted at the commutator end of the armature shaft adjacent to the housing at that end; a pinion that transmits the motor drive is secured to the armature shaft outside the housing at the drive end. Two studs anchored in the brake coil housing extend through the commutator end housing and magnet assembly into recesses in the web of the drive end housing, where nuts and washers are fitted to the studs, thus securing together the end housings and the magnet assembly. A flange, integral with the drive end housing, is the mounting base for the motor; four holes at the corners of the flange being the attachment points. The position of the end housings relative to the magnet assembly is established by dowels in the yoke and mating slots in the housings; the joints are formed by spigots in the yoke and counterbored recesses in the housings.

**7.** The brushgear is enclosed in the commutator end housing. It is secured to the commutator housing end plate by two studs and nuts, fitted in its mounting plate. The studs extend through kidney-shaped slots in

**RESTRICTED**

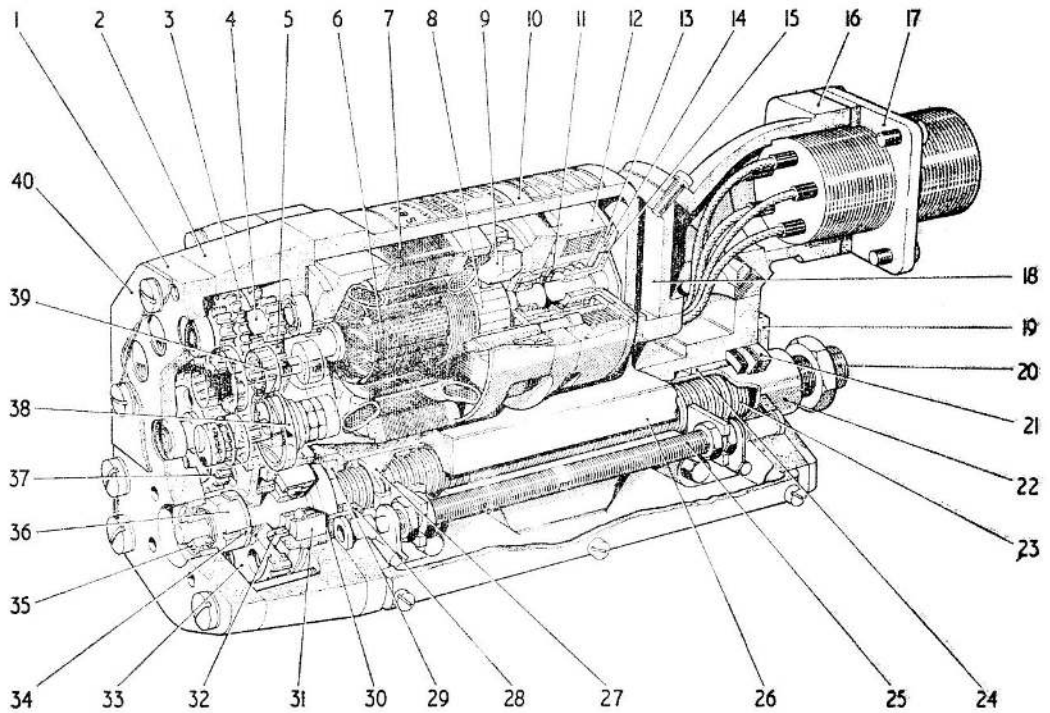

- |    |                           |    |                                |
|----|---------------------------|----|--------------------------------|
| 1  | GEARBOX COVER             | 21 | STOP WASHER                    |
| 2  | GEARBOX HOUSING           | 22 | PLUNGER                        |
| 3  | FIRST GEAR                | 23 | LEAD SCREW                     |
| 4  | FOURTH GEAR               | 24 | PLUNGER GUIDE BUSH             |
| 5  | MOTOR PINION              | 25 | OPERATING ROD                  |
| 6  | MOTOR ARMATURE            | 26 | PLUNGER HOUSING                |
| 7  | MAGNET ASSEMBLY           | 27 | TRIP EAR                       |
| 8  | COMMUTATOR                | 28 | STOP HOUSING                   |
| 9  | BRUSH GEAR                | 29 | STOP WASHER                    |
| 10 | MOTOR COVER               | 30 | SHIMS                          |
| 11 | BRAKE SPRING              | 31 | LEAD SCREW MAIN BEARING        |
| 12 | BRAKE COIL HOUSING        | 32 | DISTANCE TUBE                  |
| 13 | DISC                      | 33 | FINAL DRIVE GEAR               |
| 14 | FRICTION LINING           | 34 | TAG WASHER                     |
| 15 | BRAKE PLATE               | 35 | LEAD SCREW SPIGOT BEARING      |
| 16 | PLUG ADAPTOR SEATING      | 36 | SECURING NUT                   |
| 17 | PLUG ASSEMBLY             | 37 | SEVENTH GEAR                   |
| 18 | PLUG ADAPTOR              | 38 | SIXTH GEAR AND CLUTCH ASSEMBLY |
| 19 | PLUNGER HOUSING END COVER | 39 | FIFTH GEAR                     |
| 20 | STUD                      | 40 | PLATE                          |

**Fig. 2. Sectional view of actuator**

**RESTRICTED**

the end plate into spaces formed between the commutator housing end plate and cut-aways in the brake coil housing. This arrangement provides ready access to the nuts and studs, thus enabling easy adjustment of the brushgear in relation to the commutator when setting up speed balance. Access to the brushes is provided through slots in the commutator end housing.

8. The brake unit comprises a disc with a friction lining on one face, a plate with an integral hollow shank, a coil and a spring. The coil is contained in a cylindrical housing held securely against the commutator end housing by the two main motor studs anchored in it. The disc, which has a central aperture, is mounted on three pins anchored in the coil housing. The armature shaft extends through the coil housing and the disc and has the brake plate fitted to it, adjacent to the disc. The disc is loaded against the plate by the spring which is compressed between it and the commutator housing end plate. The brake plate is secured to the armature shaft by a tubular nut and a washer; a slot in its shank, which is encircled by the brake spring, locates on flats on the shaft. The brake disc is held at a pre-determined distance away from the coil housing by shims fitted between the shank of the brake plate and the inner race of the bearing in the commutator end housing. The brake coil is connected in series with the motor field circuits as shown in the schematic circuit diagram of the actuator in Fig. 3.

## Gearbox

9. The gearbox comprises a housing and cover bolted together to form a chamber which encloses the gears. The outer face of the housing is suitably adapted for mounting and attachment of the motor and the actuator body; the cover accepts the rear end fitting. Ball bearings for support of the gear shafts are fitted in apertures in the cover and housing. End float is eliminated by means of a washer inserted between each bearing and a plate screwed to the outer face of the housing, and disc type spring washers which force the cover bearings against the shoulders of the gear shafts, thus biasing the gear and bearing assemblies against the washers in the housing. These disc washers are retained in the cover bearing apertures by a plate secured to the outer face of the cover by screws. Apertures are also provided to accommodate the leadscrew spigot bearing in the cover, and the main bearing in the housing; the main bearing aperture is fitted with a shrunk-in liner.

## Gears and clutch

10. There are seven compound spur gear and pinion assemblies, all or some of which may be used in the drive transmission, and one single spur gear which is the final drive gear and attached to the leadscrew.

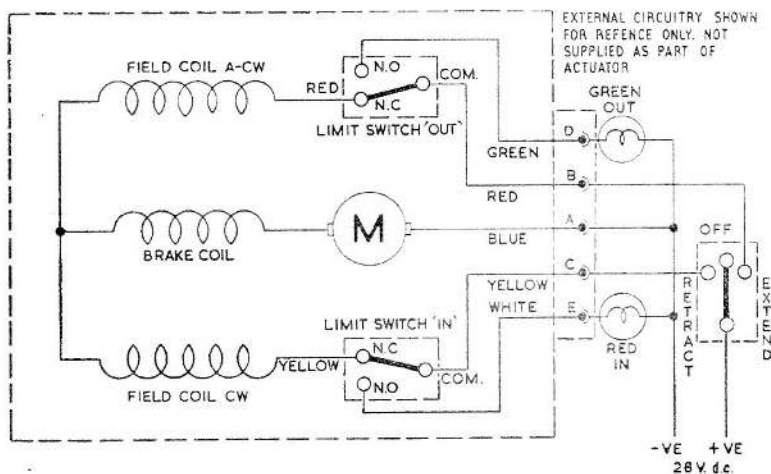

Fig. 3. Circuit diagram

RESTRICTED

**Note . . .**

*In the following text the compound spur gear and pinion assemblies are identified by their numerical sequence in the gear train drive when the entire range is used for drive reduction.*

11. Each gear assembly except the fourth comprises a spur gear and pinion; the fourth has two pinions and the spur gear. All gears except the 4th and 6th are machined from solid, the first gear and pinion being separated by a hollow bushed shank. The 4th gear is secured by pinning, and the two parts of the 6th gear form the clutch assembly. The ends of the shafts are ground to form journals for support in the bearings fitted in the gearbox; the first gear assembly is mounted on, and rotates around, the third gear shaft.

12. The gear assemblies are arranged to one of three configurations according to the gearbox ratio required.

13. The clutch is incorporated in the sixth gear assembly. Integral with the shaft and adjacent to the pinion is a flange to which a friction lining is attached. The spur gear is mounted on the shaft and loaded against the friction lining by a spring and a nut fitted to the threaded end of the shaft. The nut pre-tensions the spring and is tightened sufficiently to ensure that slip occurs between the friction lining and the gear when a load of 550 to 750 lb. is applied to the actuator. The nut is locked at its established setting by a second nut. A view of the sixth gear assembly is shown in Fig. 4.

**Leadscrew, plunger and final drive gear**

14. The leadscrew is machined from solid stock to 12 T.P.I., right hand, Acme thread form for the greater portion of its length. The plunger is essentially a tube provided with two lugs 180 degrees apart which project from its periphery at one end, and is blanked off at the other end by a stud. It is internally bushed and threaded to the same Acme thread form as the plunger, at the lug end. The plunger is screwed on to the leadscrew and its lugs locate in two

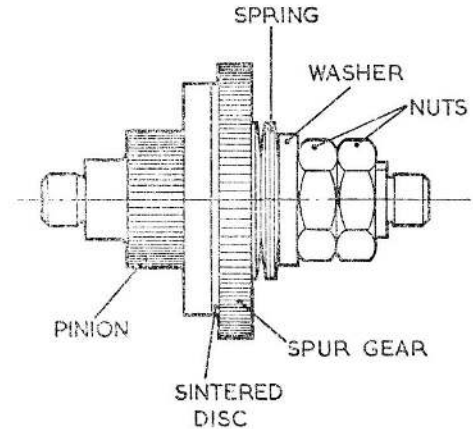

**Fig. 4. Sectional view of sixth gear assembly**

linear slots in a housing which encloses the plunger. The leadscrew is supported at its inner end in a ball bearing located in the gearbox housing. The plunger is supported at the forward end by a bush fitted in the plunger housing.

15. The leadscrew extends into the gearbox and is spigot-located in a bearing assembled in the gearbox cover. It is rotated by the final drive gear mounted on it.

16. The final drive gear has a slotted shank which engages with a pin that is fitted through the leadscrew behind the main bearing; the gear is secured on the shaft by a nut and tag washer. A distance tube which fits closely round the gear shank and drive pin is interposed between the gear wheel and the inner race of the main leadscrew bearing, retaining the drive pin.

**Main body**

17. This is a cast and machined assembly comprising the motor cover and the plunger housing. It is secured to the gearbox housing by screws, nuts and washers. Shims are inserted between a spigot at the end of the plunger housing and the outer race of the leadscrew bearing to give a 0.001 in. to 0.002 in. clearance, thus limiting the bearing end float. The main body is suitably adapted for attachment of the actuator components mounted on, and secured to it.

**RESTRICTED**

### Limit switch assemblies

18. Two limit switch assemblies are fitted to these actuators, they are mounted on one side of the plunger housing by screws, washers and nuts in a chamber whose walls are integral with the housing; these assemblies are not interchangeable.

19. Each assembly basically comprises a micro-type snap-action change-over switch, a leaf spring with an integral biased mounting strip, and a mounting plate. These parts are themselves identical for each assembly,

but are assembled to establish their functions and mounting positions.

20. Three lugs, extending through the switch mouldings, provide the terminal connections to the switch contacts, viz. normally open (N.O.), normally closed (N.C.) and common (COM.). A spring-loaded button over which the leaf spring is poised also protrudes through the moulding to provide actuation of the switch change-over pole. The normally closed contacts of each switch are connected into a motor field coil circuit.

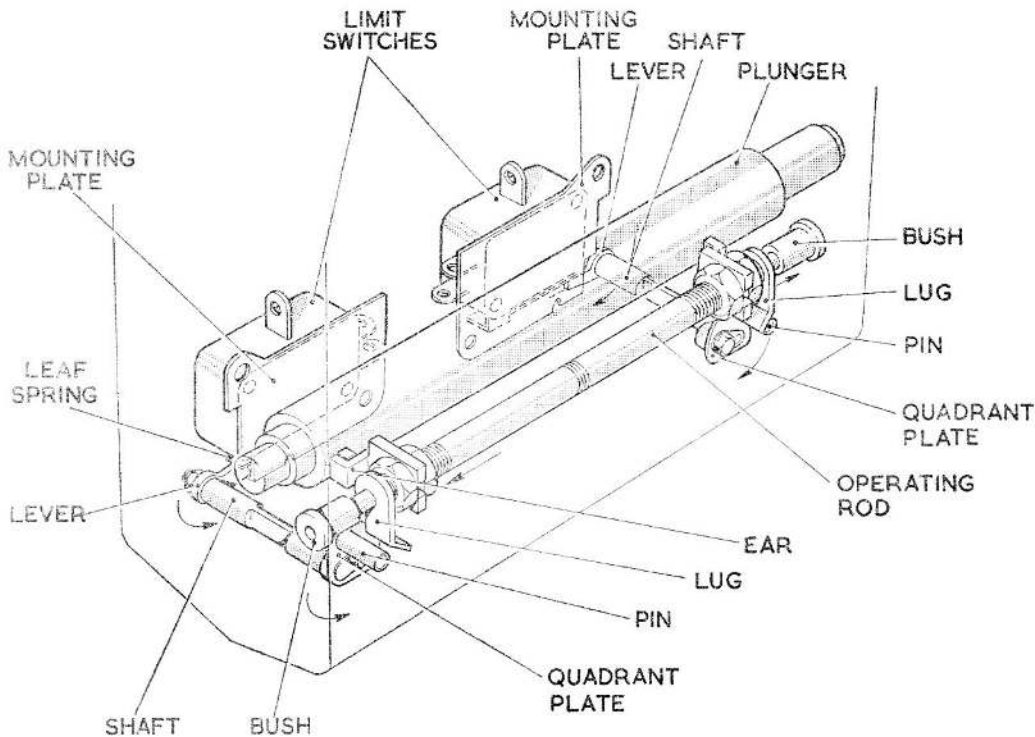

Fig. 5. Switch operation mechanism

### Switch operating mechanisms

21. A view of the limit switch operating mechanism is shown in Fig. 5. The switches are tripped by the plunger through trip mechanisms. The trip mechanisms are actuated by the lugs on a rod that is directly operated by the plunger through two ears attached to the rod. The operating rod is located in a chamber at the side of the plunger housing, opposite to the switch

chamber: the walls of the chamber are integral with the plunger housing. The trip mechanisms extend transversely through the plunger housing and bridge the operating rod and the switches.

22. The operating rod is a slender threaded shaft, supported at each end by bushes in a line parallel with the plunger. The rod is a free fit in the bushes and can slide linearly

RESTRICTED

in them. The rod lugs are of special form and brazed to the rod; the ears are secured to the rod by nuts, their positions being adjustable. The ears locate in the same plunger housing slots as the plunger lug nearest to them, their positions on the rod being determined by the actuator stroke.

23. Each trip mechanism consists of a shaft to which a quadrant plate is attached at the operating rod end and a lever at the switch end. The mechanisms and their component parts are not interchangeable. The shaft, which is supported in a bearing sleeve fitted in the plunger housing, has a thin flat centre section to absorb torsional loads imposed on it during over-travel of the plunger. The quadrant plate is secured to a lug integral with the trip shaft, by a screw and tag washer. The plate is fitted with a pin which is contacted by the appropriate operating rod lug and thus transmits movement of the rod to the trip shaft. The lever at the switch end of the shaft has a slotted shank which locates on flats on the shaft; its finger locates between the leaf spring and a flange on the switch mounting plate. The lever is secured to the shaft by a washer and nut.

#### Mechanical stops

24. The mechanical stops are cushioning arrangements to arrest the plunger in the event of switch failure. There are two stops, one fitted at each end of the plunger housing. The rear stop is assembled on the leadscrew and is a thick rubber ring secured between the leadscrew shoulder and a metal washer by a detachable housing. The closed end of the stop housing locates in an aperture in the plunger housing; its open end extends into a mating recess in the gearbox housing.

25. The forward mechanical stop is also a rubber washer which encircles the plunger and is secured against the flange of the plunger bearing bush by the plunger housing end cover. Shims are fitted on either side of the plunger bearing bush flange to set the position of the stop relative to the forward limit switch and to adjust the degree of compression of the rubber washer. This washer also constitutes the plunger seal.

#### Plug assembly and adapter

26. The plug assembly is secured to a seating and mounted on an adapter. The adapter is secured to the main body on the top of the plunger housing in front of the motor cover. The position of the seating relative to the adapter, and of the adapter itself to the main body, can be varied to derive one of six plug positions.

27. The plug assembly comprises a 5-pin plug with colour-coded leads attached to its crimped tags. The plug may be of the flame-proof or non-flameproof type, according to the design specification for the particular actuator.

#### End fittings

28. The end fittings for each actuator vary according to the application of each unit. The fittings may be standard or manufactured to a special design.

29. The rear end fitting is the anchorage for the actuator. It is bolted to the rear gearbox cover and spigot-located in the lead-screw bearing aperture. The front end fitting which can be of the self-aligning eye type, is screwed on to the stud at the front of the plunger tube and locked by a nut.

#### Covers and gaskets

30. There are four covers, one at each side, one at the front of the plunger housing and one at the rear of the gearbox. The covers are secured to the housing by screws and washers.

31. Ten gaskets inserted between mating faces at various locations are used. The gaskets are all resistant to Skydrol 500 fluid.

### OPERATION

#### Note . . .

*In the following text, directions of rotation are those established when the motor is viewed from the drive end, or the actuator from the mounting bracket or rear end.*

**32.** When the electrical circuit to the actuator is made by moving the external selector switch to the required position, one field coil and the brake coil are simultaneously energized, the brake disc is electromagnetically attracted towards the brake housing, thus releasing the motor brake, and the armature rotates. For retraction the yellow field coil is energized and the armature rotation is clockwise; for extension the red field coil is energized and the armature rotation is anti-clockwise.

**33.** In the basic actuator the motor pinion meshes with the first gear and the drive is transmitted in sequence through the 333:1 ratio gear train, which comprises all the compound spur gear and pinion assemblies, when the final gear rotates the leadscrew.

**34.** When the leadscrew rotates either in a clockwise direction during retraction or an anti-clockwise direction during extension, the plunger lugs (which locate in the linear slots in the sides of the plunger housing) restrain the plunger from rotating with the leadscrew and the plunger is driven linearly forward (extended) or backward (retracted). The plunger lug adjacent to the switch operating rod housing then contacts one of the switch operating rod ears and slides the rod forward or backward in its supporting bushes. The lug at the end of the rod contacts the pin in the quadrant plate and, on further travel of the plunger, the plate swivels and, being attached to the trip shaft, rotates the shaft. When the trip shaft rotates, the lever at the switch end contacts the leaf spring of the switch assembly; the leaf spring depresses the switch button until the switch change-over pole snaps into the normally open position. Power supply to the motor is now interrupted and the circuit to the external indicator is made. The lamp lights indicating that the pre-set limiting position of the plunger has been reached.

**35.** When the power supply to the motor is interrupted the field coil and brake coil are de-energized, the magnetic field around the brake coil collapses and the brake disc is forced into contact with the brake plate by the brake spring. Braking is thus rapidly effected and the actuator plunger is locked in position.

**36.** If, due to malfunctioning of the stroke-controlling arrangements, viz. switch, operating mechanism and circuitry, power supply to the motor is not interrupted, the plunger will continue to move forward during extension until its lugs butt against the supporting bush in the housing and move it forward. The rubber stop behind the bush will be compressed, absorbing the initial shock load, and when the limit of compression is reached the plunger will stall and the clutch slip. During retraction, a similar sequence occurs. The plunger continues to move backward until it contacts the rear mechanical stop housing and moves it backward. The rubber stop inside the housing is compressed, absorbing the initial shock load, and when the limit of compression is reached the plunger is stalled.

**37.** The foregoing notes detail the sequence of events when movement of the plunger is externally initiated, but controlled to pre-set limits of travel by features designed into the actuator. If it is desired to arrest movement of the plunger prior to a pre-set limit, it is necessary to move the external selector switch to its central "OFF" position, thereby interrupting power supply to the motor when the required plunger position is reached. When power supply to the motor is interrupted, the sequence of events detailed in para. 35 occurs and the plunger is locked in its selected position.

## INSTALLATION

**38.** For details of an actuator installation in a particular aircraft, reference should be made to the appropriate aircraft Air Publication. The installation diagram, fig. 6, will apply generally to all actuators of this series when installing in aircraft.

**39.** When fitting a new or overhauled unit, first check that the actuator is of the correct type for the installation; no adjustments should be made to the plunger travel, except when the actuator is fitted to the linear actuator test rig. Check that the actuator has not been damaged in transit, that all external screws, nuts and bolts are fully tightened and that the necessary fittings are available for securing the actuator to its

**RESTRICTED**

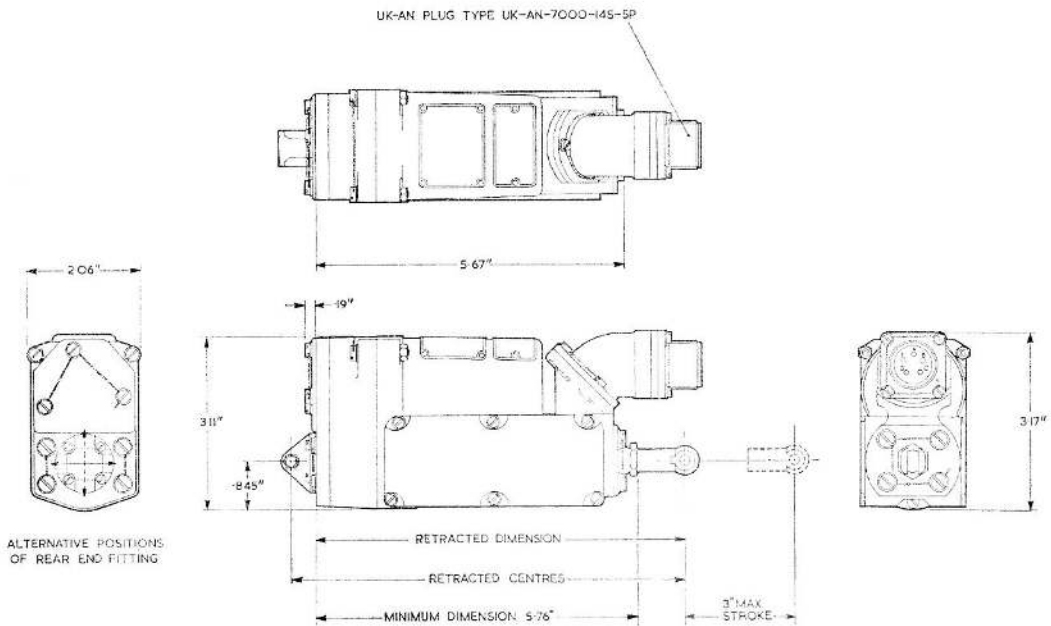

**Fig. 6. Installation diagram**

associated component. Ensure that the plunger of the actuator and the drive shaft of the associated component are correctly positioned before coupling them together.

**40.** After the actuator has been installed, check the security of the installation and operate the actuator to ensure that it functions correctly.

## SERVICING

### General

**41.** Routine servicing of the installed actuator consists of examination for security of mounting, serviceability of electrical connections and signs of damage, deterioration, or corrosion. At intervals prescribed in the relevant Aircraft Servicing Schedule the actuator is removed for bay servicing.

### Bay Servicing

**42.** On removal from an aircraft the actuator should be cleaned externally and examined for signs of damage or corrosion,

it should then be dismantled to the extent necessary to enable the bearings to be cleaned, examined and lubricated; for the brushgear and commutator to be cleaned and examined and for new brushes to be fitted and bedded.

### Dismantling

**43.** To gain access to the brushes, the actuator must be partially dismantled (see fig. 1, 2, 3 and 5) as follows: —

- (1) Check that the plunger is clear of the limit switches, then slacken the locknut and remove front end fitting, if present.
- (2) Remove both side plates (six screws each).
- (3) Cut any thread lacing on leads, then slide back sleeving on the common (blue) lead and unsolder the connection.

**RESTRICTED**

(4) Note the position and identity of the connections to the limit switches, then remove the motor tags, using a slim screwdriver. The motor tags are attached to the lowest terminal of each switch. Red to the left hand side switch and Yellow to the right hand side switch.

(5) Turn the actuator over and free the two nuts holding the trip ear (IN) nearest the gearbox. Run the inner nut towards the centre and lift the trip ear out of the slot in the housing (there is a dimple in the threaded rod to permit this).

(6) Remove the four bolts securing the rear bracket and collect the rear bracket. These bolts pass right through the gearbox.

(7) Remove the two nuts and bolts which pass through the web near the labels, also the remaining bolt underneath.

(8) Loosen the joint at the gasket between the front housing and gearbox and ease them apart. Withdraw the gearbox complete with motor and plunger from the front housing.

(9) Take out the four screws and dismount the motor.

### Brushgear

44. The brushes must be a smooth sliding fit in their holders and their lengths must not be less than 0.25 in.

45. All traces of carbon dust should be removed from the commutator and brushgear, using dry compressed air. New brushes should be fitted at the intervals prescribed in the bay servicing schedule and whenever examination reveals that they may reach their minimum length before the next servicing. The brush spring pressure should be within  $3\frac{1}{2}$  and  $4\frac{1}{2}$  oz., measured with a suitable tension gauge, with the tip of the spring level with the top of the brush holder.

46. Information on brush bedding is contained in A.P.4343, Vol. 1, Sect. 1, Chap. 2. The final bedding is accomplished by

running the motor at 12 volts on no-load for half-hour periods in each direction of rotation with the brake mechanism removed. The input voltage should be adjusted as necessary to ensure that the motor speed does not exceed 15,000 rev./min. The bedding run should be continued until each brush is bedded over its full thickness and at least 80 per cent of its contact surface. Care should be taken to avoid overheating of the motor during this running. All traces of carbon dust must again be removed when the bedding is satisfactorily completed.

### Lubrication

47. Bearings should be cleaned with lead-free gasoline, or white spirit, to remove old grease and foreign matter. Dry compressed air should be used to dry the bearings, care being taken to avoid spinning the races by the air jet. Serviceable bearings should be regreased immediately after drying by pressing grease XG-275 between the inner and outer races for a distance of one-third of their circumference and rotating the bearings by hand to distribute the grease evenly over the tracks.

### Re-assembling the actuator

48. Re-assembly is performed generally in reverse order to dismantling, replace motor exactly as found, insert gearbox and motor assembly into the front housing and secure, together with the rear bracket, using the appropriate nuts and bolts. The four bolts holding the rear bracket must be tightened to a torque of 20 lb. in. Connect up the leads to the limit switches and the soldered joint in the common Blue lead, re-sleeving the latter as found, and replace all ties and lacings. Return the inside trip ear to the slot in the main housing and lock with nuts in its appropriate original position.

### Note . . .

*The removal of the trip arm invalidates the stroke setting of this actuator. Instruction for resetting the stroke after re-assembly will be issued later. The two disc plates should not be replaced until testing is completed and any necessary adjustments have been made. Fit the side plates and secure each with the screws provided (6 for each) and replace any front end fitting as found.*

**RESTRICTED**

**Testing**

**49.** The insulation resistance of the actuator should be measured, using a 250 volt insulation resistance tester connected between the framework of the machine and each cable in turn. A minimum value of 50,000 ohms should be obtained.

**50.** The actuator should then be mounted on the Linear actuator test rig in accordance with the instructions contained in A.P.4343S, Vol. 1, Book 2, Sect. 8, Chap. 3 and tests made as detailed in Appendix 1 and in the Standard Serviceability Tests of Appendix A and Table 1.

**Appendix A****STANDARD SERVICEABILITY TESTS****PLESSEY RATIONALIZED JAGUAR ACTUATORS****LIST OF TABLES**

	<i>Table</i>
<i>Actuator, type 500/1/00257/300</i> ...	1

**Introduction**

1. The tests detailed in this appendix are intended to check the serviceability of actuators after servicing, or whenever their serviceability is in doubt.

tester Type C, or equivalent, measure the insulation resistance between the actuator frame and each cable core. The reading in each instance should not be less than 50,000 ohms.

**Test equipment**

2. The following test equipment is required:—

- (1) Tester, insulation resistance, Type C, Ref. No. 5G/152
- (2) Test rig, Linear actuator, Ref. No. 4G/5420
- (3) Tension gauge, Mk. 3, Ref. No. 1A/56 (or equivalent)
- (4) A direct current supply, variable between 18 and 29 volts.

**Functional tests**

4. The actuator should be fitted to the test rig in accordance with the details contained in A.P.4343S, Vol. 1, Book 2, Sect. 8, Chap. 3 and connected to an 18 to 29 volt d.c. supply. The length of the stroke should be measured after the actuator is run on no-load to both the extended and retracted positions. Where necessary the limit switch trip levers should be adjusted to bring the strokes within the relevant limits. The actuator should then be operated through its full stroke under the various loads and input voltages shown in the appropriate table to check that its performance is within the tabulated limits as listed in Table 1 below. There should be no excessive vibration during the tests and the actuator should be inched in each direction to check that the brake functions satisfactory.

**Insulation resistance test**

3. Using a 250V d.c. insulation resistance

**RESTRICTED**

**TABLE 1**

Applied Voltage	Load (lb.)	Condition of load	Time in seconds for full stroke (3 in.)		Maximum current (Amperes)	Stroke variation limits
			Min.	Max.		
29	200	C.L.O.	12.0	15.4	2.26	
29	200	C.L.A.	9.0	11.6	1.8	-0.020 in.
29	200	T.L.O.	12.0	15.5	2.26	
29	200	T.L.A.	9.0	11.6	1.8	+0.020 in.
29	0	Extend	8.0	10.8	1.6	
29	0	Retract	8.0	10.8	1.6	
18	0	Extend	13.0	17.0	1.4	
18	0	Retract	13.0	17.0	1.4	

CLO—compressive load opposing

CLA—compressive load assisting

TLO—tensile load opposing

TLA—tensile load assisting

**Note . . .**

*Stroke variation limits are the maximum permitted deviations from the nominal extend and retract dimensions given in Table 1 in Appendix 1, at the stipulated voltages and load.*

## Appendix 1

## ACTUATORS, RATIONALISED JAGUAR VARIANTS

## PLESSEY PART NO. 500/1/00257/300

## LEADING PARTICULARS

<i>Voltage range</i>	...	...	...	...	...	...	...	...	18-29V d.c.
<i>Normal voltage</i>	...	...	...	...	...	...	...	...	28V d.c.
<i>Normal working load</i>	...	...	...	...	...	...	...	...	200 lb.
<i>Maximum working load</i>	...	...	...	...	...	...	...	...	300 lb.
<i>Maximum static load</i>	...	...	...	...	...	...	...	...	800 lb.
<i>Rating at normal load</i>	...	...	...	...	...	...	...	...	1½ mins.
<i>Maximum operating frequency</i>	...	...	...	...	...	...	...	...	50 inching cycles/hour
<i>Ambient temperature range</i>	...	...	...	...	...	...	...	...	-50°C to +100°C
<i>Gear ratio</i>	...	...	...	...	...	...	...	...	147:1
<i>Clutch setting</i>	...	...	...	...	...	...	...	...	550/750 lb.
<i>Weight</i>	...	...	...	...	...	...	...	...	2 lb. 8 oz.
<i>Plug type</i>	...	...	...	...	...	...	...	...	UKAN 7000-145-5P
<i>Motor, Type 1606H/52</i>	...	...	...	...	...	...	...	...	Plessey Part No. 501/1/05550
<i>Output (rated)</i>	...	...	...	...	...	...	...	...	0.03 HP at 1500 rev./min.
<i>Commutator dia. new</i>	...	...	...	...	...	...	...	...	0.490/0.495 in.
<i>(min. after skimming)</i>	...	...	...	...	...	...	...	...	0.470 in.
<i>Worn</i>	...	...	...	...	...	...	...	...	0.450 in.
<i>Undercut mica intersegments, depth</i>	...	...	...	...	...	...	...	...	0.020/0.025 in.
<i>width</i>	...	...	...	...	...	...	...	...	0.018/0.022 in.
<i>Maximum eccentricity of commutator to shaft journal</i>	...	...	...	...	...	...	...	...	0.0003 T.I.R.
<i>Bearing, drive end</i>	...	...	...	...	...	...	...	...	Fischer FJP2P
<i>commutator end</i>	...	...	...	...	...	...	...	...	Fischer FJP2P
<i>Brushes</i>									
<i>Grade</i>	...	...	...	...	...	...	...	...	Type CM5H
<i>New length</i>	...	...	...	...	...	...	...	...	0.355/0.385 in.
<i>Minimum length</i>	...	...	...	...	...	...	...	...	0.25 in.

## LIST OF ILLUSTRATIONS

	Fig.
<i>General view of actuator</i>	1
<i>Arrangement of gearbox</i>	2

RESTRICTED

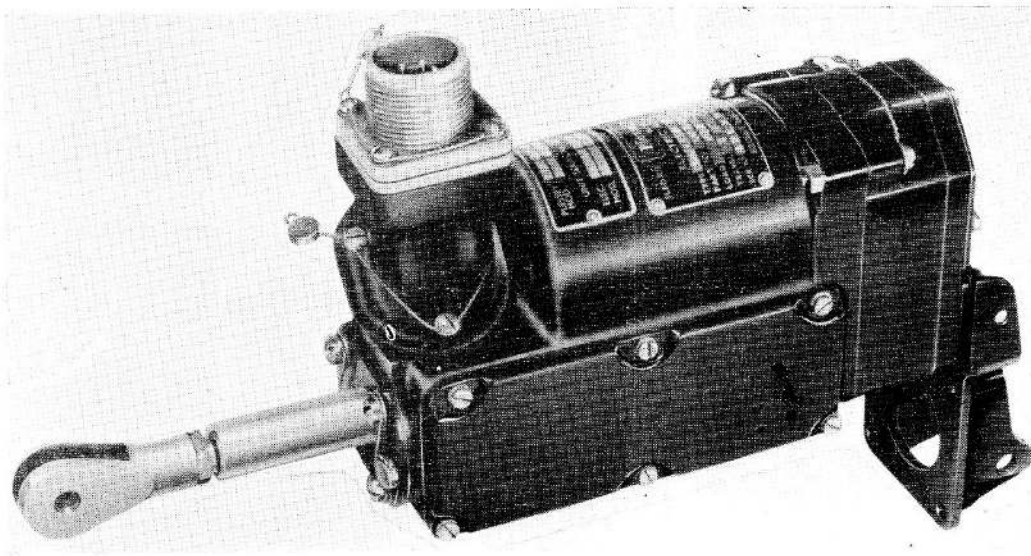

Fig. 1. General view of actuator

1. Actuator, Plessey Part No. 500/1/00257/300 is a variant in the Rationalised Jaguar series described in the main chapter, to which reference should be made for all general details. A distinguishing feature of this unit is the provision of a bracket on the rear end which projects below the actuator. A general view is shown in Fig. 1.

2. The arrangement of the 147:1 version

of the gearbox which is used in this variant is illustrated in Fig. 2. The motor pinion meshes with the third gear assembly, whence the drive is transmitted progressively to the leadscrew. The first and second gears are isolated and remain stationary. This gearbox, the attitude of the plug, the type of rear end fixing and the centres dimensions together establish the individuality of the /300 variant.

TABLE 1

Stroke setting and installation details for 500/1/00257/300 actuator

Stroke (nominal)	3 in.
Retracted dimension (from the back of the solenoid mounting bracket, under the attaching screw heads)	7.140 in. $\pm 0.000$ $-0.010$
Extended dimension; as above	10.140 in. $\pm 0.010$ $-0.000$
Front end fitting	Plessey Part Number 500/2/00475
Rear end fitting	Plessey Part Number 500/2/00474 together with 500/2/01156

RESTRICTED

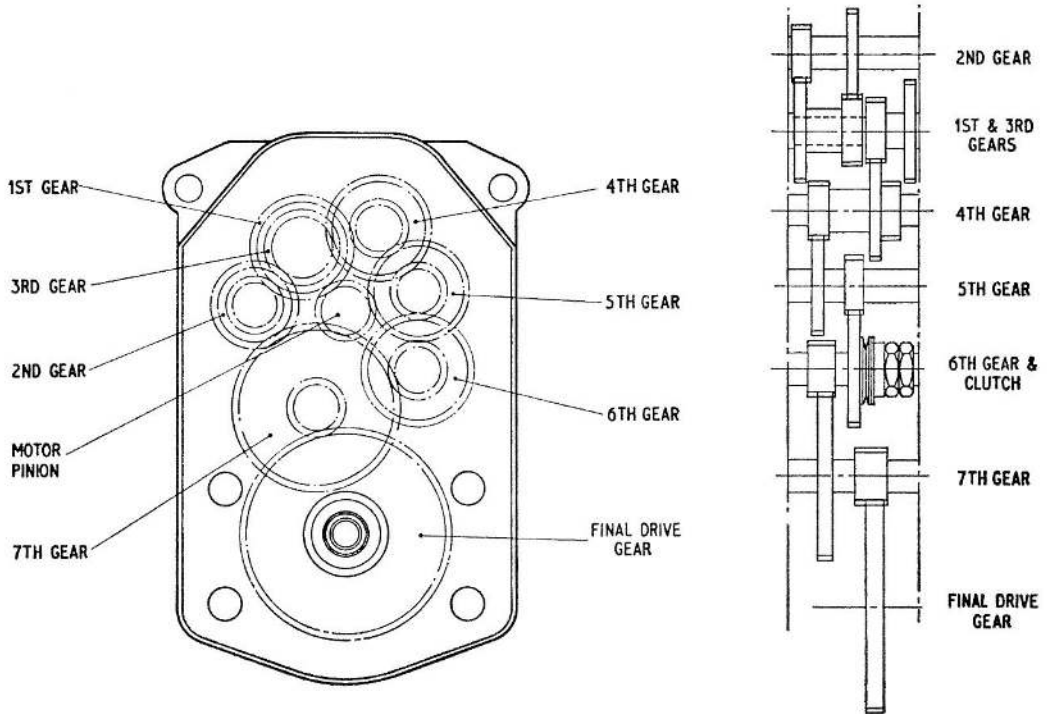

**Fig. 2. Arrangement of gearbox**

3. Stroke setting and installation details are set out in Table 1. Reference should be made to Fig. 6 in the main chapter for the datum points used in determining the retracted centres and dimensions, except where separately described.

#### **Linear backlash check**

4. With the plunger in mid-stroke position the overall backlash between fixing centres (excluding end fittings), against a 10 lb. load

in compression and tension, should not exceed 0.010 in.

#### **Rotation backlash check**

5. The rotational backlash between the plunger and the plunger housing should not exceed 1.5 degrees when the plunger is in the mid-stroke position.

#### **Note . . .**

*1.5 degrees is equivalent to a dimension of 0.131 in. at a 5.0 in. radius from the actuator centre line.*

**RESTRICTED**

This file was downloaded  
from the RTFM Library.  
Link: [www.scottbouch.com/rtfm](http://www.scottbouch.com/rtfm)  
Please see site for usage terms,  
and more aircraft documents.

