

Chapter 4

ACTUATORS, ROTAX, A2700 SERIES

LIST OF CONTENTS

	<i>Para.</i>		<i>Para.</i>
<i>Introduction</i>	1	<i>Limit switches</i>	7
Description	2	<i>Position indicator</i>	8
<i>Motors</i>	3	<i>Operation</i>	9
<i>Brake and clutch</i>	4	Installation	11
<i>Gearbox</i>	5	<i>Electrical connections</i>	12
<i>Ram and screwshaft</i>	6	Servicing	13
		<i>Testing</i>	15

LIST OF ILLUSTRATIONS

	<i>Fig.</i>
<i>Typical A2700 series actuator</i>	1
<i>Diagram of internal connections</i>	2

LIST OF APPENDICES

	<i>App.</i>
<i>Standard serviceability test for actuators, Rotax, A2700 series</i>	A
<i>Actuator, Rotax, Type A2702</i>	1
<i>Actuator, Rotax, Type A2703</i>	2
<i>Actuator, Rotax, Type A2704</i>	3

RESTRICTED

Introduction

1. Units in the A2700 series are tailplane surface actuators for use on aircraft having a 28 volt d.c. supply. The actuator incorporates a potentiometer to provide an indication of flap position on an external Desynn type indicator. The unit is designed to give satisfactory operation over a temperature range of -60 deg. C. to $+100$ deg. C. and at altitudes up to 40,000 ft.

DESCRIPTION

2. The actuator has a main and an auxiliary motor, each of which is provided with a clutch assembly, driving disc, electro-magnetic brake, and reduction gear train. By this means either motor can be used independently of the other to drive the ram unit.

Motors

3. Both motors are four pole, four brush reversible shunt wound machines, designed to give approximately constant speed with varying loads. Reversal of operation is effected by changing the field or armature connections externally.

Brake and clutch

4. The brake coil is connected in series with

the d.c. supply and arranged so that the actuator is locked when the motor is de-energized and released when energized. A disc clutch is incorporated to allow the armature to dissipate its kinetic energy when the brake is applied, thus assisting the deceleration of the ram.

Gearbox

5. Drive from each motor output shaft is transmitted via the clutch, driving disc and pinion assembly, to the respective epicyclic reduction gearbox. The main gearbox comprises two fixed annulus gears with a revolving annulus having an external ground track rotating in two sets of ball bearings these are assembled in the recesses of the two fixed annulus gears which act as outer journals for the balls. There are four trains of planet gear assemblies rotating in the internal annulus gears, and these complete the drive to the screwshaft gear via an idler gear mating with the fourth planet sun gear. The auxiliary gearbox contains a fixed internal annulus gear that carries two trains of planet gears, the sun gear of the second train acting as the driving pinion for the revolving annulus, via two reduction idler gears, completing the drive to the screwshaft through the third and fourth stage epicyclic planet gears in the main gearbox.

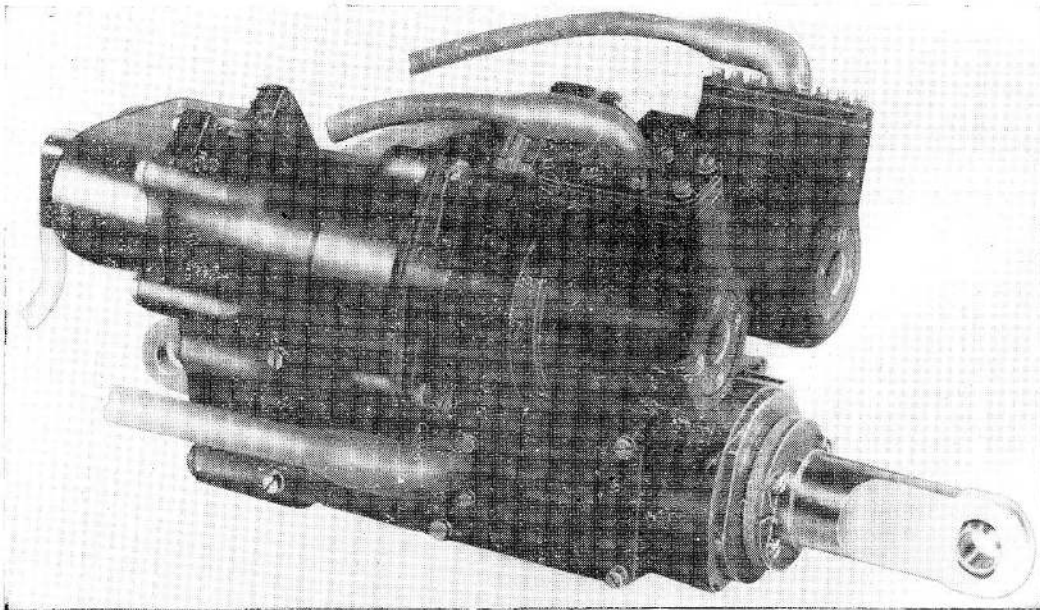

Fig. 1. Typical A2700 series actuator

RESTRICTED

Ram and screwshaft

6. The unit is constructed so that the two motors are mounted on one side of the ram assembly, with their main axis parallel to the line of stroke. The stainless steel ram is driven by a nut and screwshaft, which has a high efficiency thread of the recirculating ball type. Two sets of steel balls, located in key seats in the outer surface of the ram, run in steel guides cast in the ram housing. This arrangement provides a low friction bearing for the linear motion of the ram and takes up the torque reaction of the screwshaft.

Limit switches

7. The stroke of the ram is controlled by single pole limit switches, which for reliability are duplicated and individually wired for each motor. In the event of limit switch failure, the ram will come to rest against a mechanical stop.

Position indicator

8. A potentiometer is fitted on the end of the gearbox remote from the motors. It is mechanically driven through the gearbox, and electrically coupled to a remote magnetic

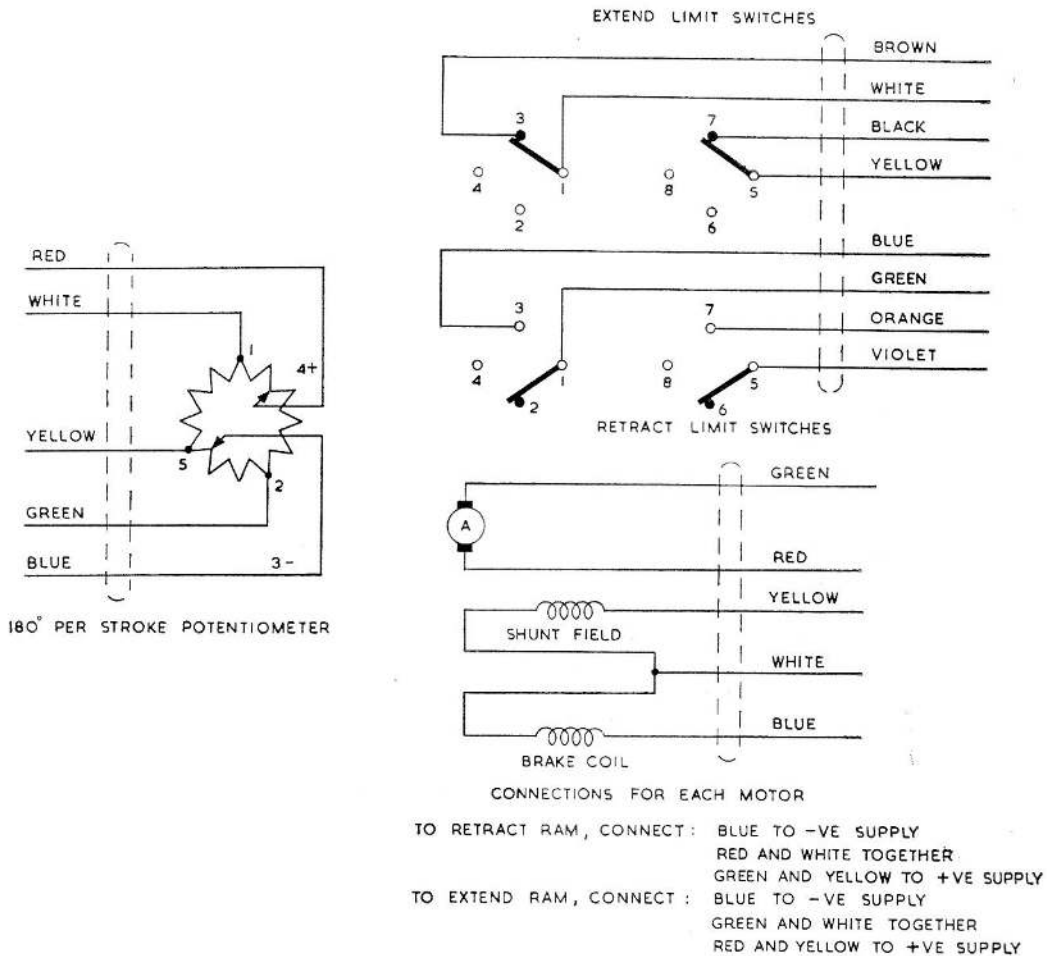

Fig. 2. Diagram of internal connections

RESTRICTED

indicator. As the ram is extended or retracted to operate the aircraft tail surface, a corresponding indication of tail position is given on an external indicator, and with each full stroke of the ram the potentiometer wiper blades are rotated through 180 degrees.

Operation

9. Upon energizing the main motor, the brake will be released and the armature will rotate. Torque is transmitted to the screwshaft gear via the epicyclic gear trains, idler gears, rotating annulus, driving disc, and over-run clutch. External gear teeth are machined on one end of the screwshaft to form part of the gear train. When this screwshaft gear is rotated the re-circulating ball thread system actuates the ram in a linear direction of travel. The re-circulating ball thread in the ram nut produces linear travel for the ram within the ram housing. When the ram has travelled to the fully extended position, limit switches that are operated by the ram will break the motor circuit, via an external contactor. Rotation of the armature will cease and the brake, now de-energized, will come into action and prevent further movement. Clockwise and anti-clockwise rotations of the motor armature are controlled by external switches, therefore when the ram has travelled to the fully extended position and has come to stop through limit switch action, the motor will require to be re-energized by the appropriate external switching arrangement to reverse its action and retract the ram.

10. The emergency motor is electrically independent of the main motor, and while the main motor is capable of functioning the emergency motor will remain static, being retained by its brake. Should there be a failure of the main motor, the emergency motor and gearbox will be brought into action by manual switching. The emergency motor is similar in operation to the main motor although the gear ratio is the same. An idler gear, which engages the sun gear of the second planetary train of the emergency motor, transmits torque to the external teeth of the revolving annulus via the mating intermediary pinion. This annulus transmits the power developed by the emergency motor to the screwshaft via the third and fourth stage epicyclic planet gears and mating idler gear. The revolving annulus is held stationary by the brake of the emergency motor while

the main motor is functioning. The emergency motor will become de-energized by the limit switches when the ram reaches the fully extended or retracted positions.

INSTALLATION

11. The mounting attitude is unrestricted; fixing attachments are made as follows:—

Fixed attachment

(1) Fork with shouldered bolt clamping to one side of fork, which has a 0.500 in. hole in one side and 0.375 in. hole in the other.

Moving attachment

(2) 'Hoffman' self aligning bush 0.500 ±0.002 in. inside diameter.

Electrical connections

12. Electrical connections are made by Pren 6 flying leads as follows:—

Motor leads (2)	Quinprensheath 6 (5-core)
Limit switch leads (2)	Nonoprensheath 6 (9-core)
Potentiometer lead (1)	Quinprensheath 6 (5-core)

Note . . .

The 9 core flying leads have the red core lead cut back at either end as only 8 core cable is used in the circuit.

SERVICING

13. Make a general inspection of the actuator to ensure that it has not sustained any damage. Ensure that it is secure on its mounting shackles and that the electrical connections are sound. Normally servicing will be confined to a general inspection of the machine.

14. To gain access to the brushgear, it is necessary to remove the motors. Since assembly involves accurate re-alignment of the gearbox, servicing of the brushgear will normally be undertaken when the unit is dismantled for repair.

Testing

15. If the serviceability of the actuator is suspect, it may be tested as laid down in Appendix A.

RESTRICTED

Appendix A

STANDARD SERVICEABILITY TEST FOR ACTUATORS, ROTAX, A2700 SERIES

Introduction

1. The following tests may be applied to the machine before it is put into Service, or at any time when its serviceability is suspect.

(1) Linear actuator test rig (Ref. No. 4G/5420).

(2) Insulation resistance tester, Type 0557/A.P.5047.

Test equipment

2. The following test equipment is required:—

Testing

Performance test

3. Set the actuator on the rig, and ensure that it operates within the following limits.

Type	Applied voltage (volts)		Load opposing (lb.)	Time for stroke of 2.660 in. (sec.)		Current (amp.) (max.)	
	Main	Emergency		Main	Emergency	Main	Emergency
A2702	28	24	0	27±10%	27±10%	7.0	7.0
	28	24	2,500	31 (max.)	31 (max.)	7.7	7.7
A2703	28	24	0	23±10%	29±10%	6.3	6.6
	28	24	2,500	26 (max.)	33 (max.)	8.0	8.5
A2704	28	24	0	15.5±10%	18±10%	10.3	8.8
	28	24	2,500	17.5 (max.)	21 (max.)	13.3	11.9

4. The actuator should also be tested with load assisting; it should complete the full travel of 0.2660 in. with no tendency for the brake to drop on.

are made; any inadvertent cross connection will burn out the potentiometer.

Potentiometer

5. To check the potentiometer against a master desynn indicator, the following connections should be made.

Actuator lead	Connection
Red	28V + ve supply
Blue	28V - ve supply
White	Terminal 1 on indicator
Green	Terminal 2 on indicator
Yellow	Terminal 3 on indicator

6. With the ram in the fully extended position, the master indicator should read 90 deg. nominal. With the ram in the fully retracted position, the master indicator should read 270 deg. nominal. With the ram retracting, the indicator needle should travel in a clockwise direction.

Note...

A variation of 2 deg. from the nominal readings is permissible.

Insulation resistance test

Note...

It is important that the supply should be switched off when these connections

7. The insulation resistance, when measured with a 250 volt insulation resistance tester between all live parts and the frame, should not be less than 0.05 megohm.

RESTRICTED

Appendix 2

ACTUATOR, ROTAX, TYPE A2703

LEADING PARTICULARS

Actuator, Type A2703						<i>Ref. No.</i> 5W/4158
<i>Voltage (main motor)</i>						28V d.c.
<i>Voltage (emergency motor)</i>						24V d.c.
<i>Current (main motor max. load)</i>						10.5 amp.
<i>Current (emergency motor max. load)</i>						11.5 amp.
<i>Over-run with relays in circuit</i>						0.010 in. max.
<i>Average working load</i>						2,800 lb.
<i>Maximum working load</i>						5,300 lb.
<i>Maximum static load</i>						7,500 lb.
<i>Brush spring load</i>					5 to 7 oz. (142 to 198 gm.)	
<i>Brush grade</i>						EGO. 9C
<i>Brush length (new)</i>						0.400 in.
<i>Brush length (minimum permissible)</i>						0.300 in.
<i>Comm. diameter (new)</i>						0.990 in.
<i>Comm. diameter (minimum permissible)</i>						0.965 in.
<i>Ram travel</i>						2.660 in.
◀ <i>Time of stroke (main motor 28V no load)</i>					23 sec. ± 10 per cent.	
<i>Time of stroke (emergency motor 24V no load)</i>					29 sec. ± 3 sec.	▶
<i>Gearbox reduction ratio —</i>						
<i>Main motor</i>						1079 : 1
<i>Emergency motor</i>						1079 : 1
<i>Operational temperature range</i>					-60 deg. C to +100 deg. C	
<i>Altitude</i>						40,000 ft.
<i>Length extended between centres</i>					15.220 in. ± 0.010 in.	
<i>Length retracted between centres</i>						12.560 in.
<i>Width</i>						6.375 in.
<i>Height</i>						6.937 in.
<i>Weight (including flying leads)</i>						21 lb.

1. The A2703 actuator is similar to that described and illustrated in the main chapter, but differs from others in the series in the time of the ram stroke on both main and emergency motors. For the A2703 the time is as follows :—

	Time of travel	Length of stroke
Main motor	23 sec.	2.660 in.
Emergency motor	29 sec.	2.660 in.

RESTRICTED

Appendix 3

ACTUATOR, ROTAX TYPE A2704

LEADING PARTICULARS

Actuator, Type A2704	Ref. No. 5W/
Voltage (main motor)	28V d.c.
Voltage (emergency motor)	24V d.c.
Current (main motor max. load)	16.7 a.m.p.
Current (emergency motor max. load)	15.7 a.m.p.
Over-run with relays in circuit	0.010 in. max.
Average working load	2,800 lb.
Maximum working load	5,300 lb.
Maximum static load	7,500 lb.
Brush spring load	4 to 5 oz. (114 to 141 gm)
Brush grade	EGO. J9C
Brush length (new)	0.400 in.
Brush length (minimum permissible)	0.300 in.
Commutator diameter (new)	0.990 in.
Commutator diameter (minimum permissible)	0.965 in.
Ram travel	2.660 in.
Time of stroke (main motor 28V no load)	15.5 sec. \pm 10 per cent.
Time of stroke (emergency motor 24V no load)	18 sec. \pm 10 per cent.
Gearbox reduction ratio—								
Main motor	1079 : 1
Emergency	1079 : 1
Temperature range	-60 deg C to +100 deg. C.
Altitude	40,000 ft.
Length extended between centres	15.220 in.
Length retracted between centres	12.560 in.
Width	6.375 in.
Height	6.937 in.
Weight (including flying leads)	21.5 lb.

1. The actuator, Type A2704 is generally similar to that described and illustrated in the main chapter; the difference is that it operates at a higher speed, and because of this the following modifications have been incorporated in the machine:—

- (1) Brush triggers instead of brush springs.
- (2) An additional ball bearing has

been fitted to the armature shaft of both motors, located in the brake coil spider.

(3) The end housing and the ram nut have been strengthened.

2. On no load, the time of the new ram stroke is as follows:—

	Time of Travel	Length of Stroke
Main Motor	15.5 sec.	2.660 in.
Emergency Motor	18 sec.	2.660 in.

RESTRICTED

Chapter 5

ACTUATOR, ROTAX, TYPE A2102

LIST OF CONTENTS

	<i>Para.</i>		<i>Para.</i>
<i>Introduction</i>	1	<i>Indicator switch</i>	12
Description	3	<i>Electrical connections</i>	13
<i>Motor</i>	4	<i>Operation</i>	14
<i>Brake</i>	6	Installation	15
<i>Clutch</i>	7	Servicing	17
<i>Gearbox</i>	8	<i>Brushes</i>	18
<i>Ram and screwshaft</i>	9	<i>Insulation resistance tests</i>	22
<i>Limit switches</i>	10		

LIST OF ILLUSTRATIONS

	<i>Fig.</i>
<i>Outline of actuator A2102</i>	1
<i>Diagram of connections</i>	2

LEADING PARTICULARS

Actuator, Type A2102	<i>Ref. No. 5W/2580</i>
<i>Voltage</i>	28V d.c.
<i>Normal working load</i>	40 lb
<i>Current draw at normal load</i>	3.5 amperes
◀ <i>Ram speed at normal load</i>	1.250 in. in 3—4 sec.
<i>Overrun</i>	0.020 in. (max.)
<i>Intermediate position</i>	0.260 in. from fully retracted ▶
<i>Maximum working load</i>	70 lb
<i>Maximum static load</i>	850 lb
<i>Maximum factored load</i>	1300 lb
◀ <i>Operational temperature range</i>	-70 deg. C. to +90 deg. C. ▶
<i>Operational ceiling</i>	60000 ft
<i>Brush grade</i>	DM.4A.
◀ <i>Brush length (new)</i>	0.343 in. ± 0.015 in. ▶
<i>Minimum brush length</i>	0.200 in.
◀ <i>Brush spring pressure</i>	2.5 to 3.5 oz. (71 to 99 gm.)
<i>Commutator diameter (new)</i>	0.5685 in. ± 0.0025 in.
<i>Minimum commutator diameter</i>	0.535 in. ▶
<i>Limit switches (four)</i>	<i>Rotax Part No. N.128234</i>
<i>Indicator switch</i>	<i>Rotax Part No. N.135071</i>
◀ <i>Length (retracted)</i>	8.187 in. ± 0.010 in.
<i>Length (intermediate)</i>	8.447 in., adjustable to 8.647 in.
<i>Length (extended)</i>	9.187 in. +0 in. to -0.010
	9.437 in. +0.010 in. ▶ -0
<i>Height</i>	4.540 in.
<i>Width</i>	2.125 in.
<i>Weight</i>	3 lb

RESTRICTED

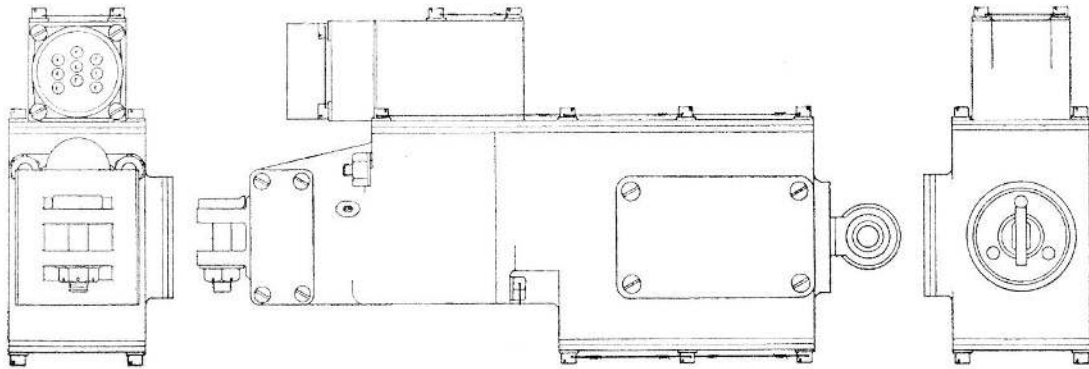

Fig. 1. Outline of actuator A2102

Introduction

1. Type A2102 actuator is a 28V d.c. linear machine capable of moving a normal working load of 40 lb, over its full ram stroke of 1.250 in. in 4 seconds. There is an intermediate position 0.260 in. from fully retracted, adjustable to 0.460 in. from fully retracted, at which the actuator can stop when extending or retracting. The maximum working load is 70 lb and the maximum static load permitted is 850 lb.

2. The actuator is fitted with four limit switches (*para.* 10), one for each end of the total stroke and one for each direction of approach to the intermediate position. There is also an indicator switch (*para.* 12) which connects pole 6 of the nine-pole plug (*para.* 13) to pole 7 when the ram is situated between the fully retracted position and the intermediate position (inclusive). This indicator switch also connects pole 6 to pole 8 from when the ram has left the intermediate position up to and including the fully extended position. This switch enables the region at which the ram is situated to be remotely indicated.

DESCRIPTION

3. The actuator is contained within two housings. The motor housing encloses the motor, brake and clutch and has the fixed shackle formed integral with the closed commutator end. Two screw retained cover plates are provided which, when removed, give access to the two brushes (*para.* 18). The body encloses the gearbox, ram and

screwshaft, together with the four limit switches, which are situated behind two screw retained cover plates set opposite one another, and the indicator switch, which is located beneath a smaller cover on one side. The ram projects through the end of the body and slides in a felt seal which is carried by a ring nut screwed flush into the end of the body. The two housings are held together by two screws passing through lugs in the body and into the motor housing, and two studs fixed in the body which project through holes in the motor housing, to be secured by nuts. A nine-pole plug (Ref. No. 5X/6182) is fitted to a plug adapter, which in turn is secured to a mounting base formed by the two main housings over the joint between them.

Motor

4. The motor is a two-pole split-field series machine, one half of the split field being used to extend the ram and the other half to retract it. The field coils are wound on a laminated yoke which is a sliding fit in a motor housing and is retained by two grub screws.

5. The armature is supported at the commutator end by a ball bearing carried by a closed liner in the end of the motor housing. The drive end of the armature shaft is supported by a friction bearing in the centre of the driving plate (*para.* 6). The two brushes are carried by boxes within a moulded brush ring. They are maintained in contact with the commutator by small triggers actuated by the brush springs.

RESTRICTED

Brake

6. The electro-magnetic brake consists of a solenoid connected in series with the motor armature, and a circular brake disc (at the end of the solenoid remote from the armature) which is normally maintained in contact with the driving plate by twelve helical springs. The brake shoe is prevented from rotating by three locating dowels.

Clutch

7. The armature drive is transmitted to the driving plate (when the motor is running and the brake disc held off the driving plate) by a single clutch plate integral with a sleeve which is a sliding fit on the armature shaft. The clutch setting is maintained by a helical spring about the armature shaft and in compression between the clutch sleeve and the end of the armature. The armature rotation is transferred to the clutch sleeve and plate by a transverse pin located in slots in the sleeve.

Gearbox

8. The driving plate is riveted to a short bearing shaft which is integral with the sun gear of the first stage of a two-stage epicyclic gearbox. The bearing shaft is carried by a ball bearing fitted in to a bearing frame which is screwed into the body. Each planet carrier of the gearbox has three planet gears running on ball bearings. The planets run within a single annulus gear, and axial movement within the gearbox is taken up by a spring loaded ball set in the centre of the first stage sun gear and bearing on the first stage planet carrier. The reduction ratio of the gearbox is 29 : 1.

Ram and screwshaft

9. The second stage planets are fitted to the end of the screwshaft, which is formed into the inner race of a double journal ball bearing which supports the entire shaft. The outer race of this bearing is formed by a liner fitted in the body. The ram is hollow, sheathing the entire screwshaft when fully retracted. The rotation of the screwshaft is converted into the linear movement of the ram by a nut fitted into the inner end of the ram, which mates with the

screwshaft thread. The ram is prevented from rotating by six balls in sockets in the ram and running in two grooves in the body wall. The ram shackle is screwed into the end of the ram; it has a self aligning bush.

Limit switches

10. The four limit switches are mounted two on each side of the body. They are operated by cams machined on the exterior of the ram. Each switch consists of a moulded block into which the fixed contacts and terminals are set. The moving contact, which is a small metal bar, is pivoted at one end to the block. A plunger projects through the base plate to engage the appropriate cam on the ram, whilst the other end bears on a moulded arm which is also pivoted to the moulded block. The moulded arm is linked to the moving contact bar by a wire spring so that if the moulded arm is pushed up by the plunger engaging its cam, the moving contact will snap into its lower position, whilst when the moulded arm is allowed to return to normal as the plunger is released by its cam, the moving contact returns with a snap action to its normal position. The moving contact mates with a fixed contact in each position. A terminal is commoned to each fixed contact, and a third terminal connects with the moving contact pivot so that this terminal is connected to one or other of the fixed contact terminals depending on the position of the ram.

11. On one intermediate switch and the extend switch, one contact is not in use so that each switch has an "open" position and a "closed" position. Each switch is normally closed and is opened by its cam as the ram reaches the intermediate position extending and the outer end of its stroke respectively. The retract limit switch connects the applied positive (pole 4) to pole 5 of the plug when it breaks the motor circuit as the ram arrives at its fully retracted position. The remaining intermediate switch is a two pole switch connecting pole 3 to the retract field when the ram is extended beyond the intermediate position and to the extend field (via the other intermediate switch) when the ram is not so far extended as the intermediate position.

Indicator switch

12. The indicator is mounted at one side of the body at 90 deg. to the limit switch positions. It is a two-pole switch operated by a plunger running in a groove in the side of the ram. The switch consists of a flat spring loaded contact arm having a double-faced contact at the tip which mates with one or other of two fixed contact strips. The switch position changes when the ram is just out beyond the intermediate position (*para. 2*).

Electrical connections

13. Electrical connections to the external circuit are made via a 9-pole breeze plug (Ref. No. 5X/6182). Pole 1 is the motor negative; pole 2 is positive for full extension of the ram and pole 4 is positive for full

retraction; the connection of positive to pole 3 will move the ram to its intermediate stop from any position. Pole 5 is connected to pole 4 via the retract limit switch (*para. 10*) whenever the ram is fully retracted. Poles 6, 7 and 8 are in the indicator switch circuit (*para. 2*) and pole 9 is not used.

Operation

14. With the ram fully retracted (*fig. 2*) supply positive to pole 2 in order to fully extend the ram on to pole 3 to move the ram to the intermediate position. When the supply is connected to the actuator, the brake solenoid is energized and pulls the brake disc off the driving plate against the compression of its springs, leaving the driving plate free to rotate. The armature gathers speed and drives the ram through the clutch, gearbox and screwshaft. As the ram reaches

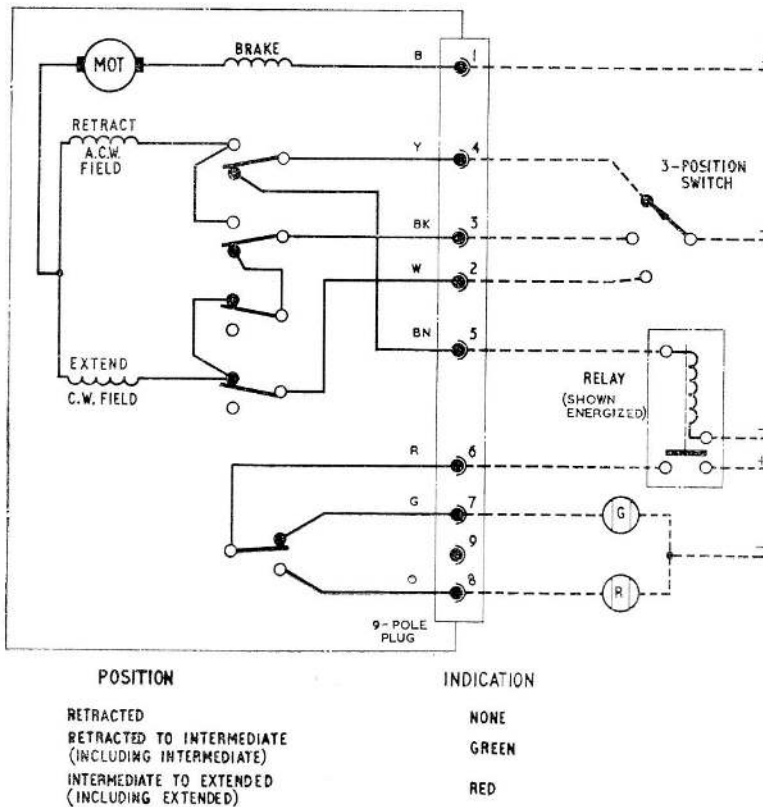

Fig. 2. Diagram of connections

RESTRICTED

the stop position, the cam on the ram engages the plunger of the appropriate limit switch which snaps in to its "open" position and breaks the supply to the motor. The brake coil is de-energized and the brake disc is applied to the driving plate by the brake springs so that the ram is thereby arrested. The momentum of the armature is then absorbed by the slipping of the clutch, with the result that the overrun of the ram is limited to a minimum.

INSTALLATION

15. The two shackles form the entire support for the actuator. The ram shackle is fitted with a self aligning joint having a bore of 0.250 in. The fixed shackle is fitted with a shackle pin of 0.250 in. in diameter.

16. The electrical connections are made by a nine-pole breeze plug (Ref. No. 5X/6182).

SERVICING

17. Make a general inspection of the actuator in order to ensure that it is in good condition and has not sustained damage. The shackle fixings should be sound and the plug connection should be clean and secure.

Brushes

18. Remove the two screw retained cover plates from the commutator end of the motor housing and make the following checks.

19. Remove the brushes from their boxes and inspect them for cracks, chipping, loose pigtails and wear. The minimum brush lengths is 0.200 in. Any brush which is worn so close to the minimum that it is unlikely to give satisfactory service until the next servicing should be discarded.

20. Ensure that the brushes are free but not slack in their boxes. If brushes are tight as a result of carbon deposits having formed in the brush boxes, the deposits should be removed.

21. Measure the brush spring pressure, using a tension gauge (Ref. No. 1H/59). The reading at the tip of the brush trigger when it is just lifted clear of the brush should be between 2.5 oz. and 3.5 oz. (71 gm and 99 gm).

Insulation resistance tests

22. Measure the insulation resistance between live parts and frame using a 250V insulation resistance tester. A reading of at least 50000 ohms should be obtained.

RESTRICTED

This file was downloaded
from the RTFM Library.

Link: www.scottbouch.com/rtfm

Please see site for usage terms,
and more aircraft documents.

