

## Chapter 40

### ACTUATORS, ROTAX, A 1300 SERIES

#### LIST OF CONTENTS

	<i>Para.</i>		<i>Para.</i>
<i>Introduction</i> ... ..	1	<i>Heater coil</i> ... ..	11
<b>Description</b> ... ..	2	<b>Operation</b> ... ..	12
<i>Motor</i> ... ..	3	<b>Installation</b> ... ..	14
<i>Brake and clutch</i> ... ..	6	<b>Servicing</b> ... ..	15
<i>Gearbox</i> ... ..	8	<i>Brushgear</i> ... ..	16
<i>Ram and screwshaft</i> ... ..	9	<i>Insulation resistance test</i> ... ..	18
<i>Limit switches</i> ... ..	10		

#### LIST OF ILLUSTRATIONS

	<i>Fig.</i>
<i>A typical actuator in the A1300 series</i> ...	1

#### LIST OF APPENDICES

	<i>App.</i>
<i>Actuator, Rotax, Type A1301</i> ... ..	1
<i>Actuator, Rotax, Type A1303</i> ... ..	2

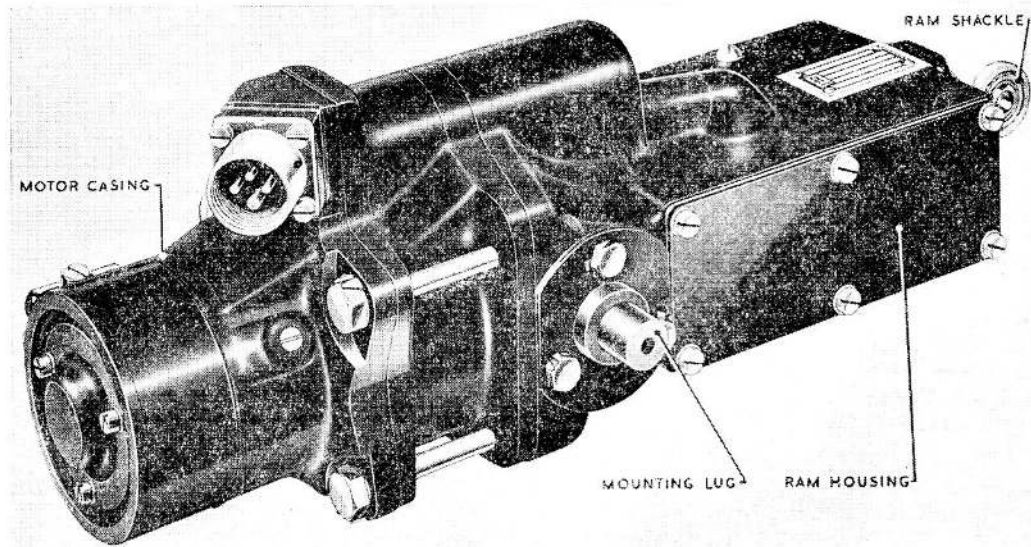

Fig. 1. A typical actuator in the A1300 series

**RESTRICTED**

## Introduction

1. The Rotax A1300 Series of linear actuators has been developed for general use in aircraft, but particularly to operate elevator trim tab controls. Additional information which applies to specific types will be found in Appendices to this chapter.

## DESCRIPTION

2. A typical machine of the A1300 Series of linear actuators is illustrated in fig. 1. These machines are of "in-line" design, with the motor and ram on the same axis, and incorporate a screwshaft of truncated Whitworth form. Mounting is made by two mounting lugs provided on the sides of the actuator. The 28-volt motor drives the ram via a 3-stage epicyclic gearbox, and its rating is continuous at an operational cycle of two seconds on and six seconds off. Between the motor and gearbox is a drum-type electro-magnetic brake and a single plate phosphor bronze clutch.

### Motor

3. The motor is a 4-pole, 2-brush machine having a split series field, each half of the field winding energizing two pole pieces. Reversal of rotation is thus affected by switching the field supply to the opposite winding.

4. The armature is supported at the commutator end by a ball bearing and is located at the driving end in a plain bearing within the brake drum, which itself runs in a ball bearing. Relative rotation between the armature and the brake drum occurs only during clutch slip.

5. External electrical connections are made either by a 4-pole plug, or by a flying lead.

### Brake and clutch

6. Between the motor and the gearbox is a drum-type electro-magnetic brake, the coil of which is connected in series with the armature. When energized, the brake shoes are drawn away from contact with the drum against spring pressure. The brake is applied when the coil is de-energized. Locating pins on the brake spider prevent displacement of the four brake shoes.

7. Interposed between the armature and the inside of the brake drum is a single plate phosphor bronze clutch. When the brake is applied, the stored energy in the armature is dissipated via the clutch, and the deceleration of the ram is assisted.

## Gearbox

8. A 3-stage epicyclic gearbox is incorporated, giving a reduction ratio of 91.125 to 1. It comprises first, second and third planetary trains. Integral with the brake drum, which extends beyond the brake housing into the gearbox, is the first sun gear. The other two gear trains are formed as integral parts of two planet carriers, the third stage of the planetary train being secured to the screwshaft. Each planet carrier has mounted on it three planet gears, and the three planetary trains revolve in a fixed annulus.

### Ram and screwshaft

9. The steel ram, housing a bronze nut, is driven by a screwshaft of truncated Whitworth form. Torque reaction is absorbed by three sets of balls located in the ram and sliding in steel guides in the ram housing. The screwshaft, at the gearbox end, is borne by, and revolves in, a double row of steel balls housed between an outer race and the annulus gear.

### Limit switches

10. The 28-volt motor circuit is controlled by four snap-action limit switches. The switches are arranged in two pairs, each pair being connected in series to provide a safety factor, and each pair, so connected, is in series with an energizing field. The switches are operated by pressure being applied by a shouldered section machined on to each side of the ram. When the correct amount of travel has been made by the ram, contact is made with the switches, and the circuit is broken.

### Heater coil

11. Located in the upper part of the ram housing is a heater coil enclosed in a metal container of cylindrical form. The purpose of this heater coil is to assist operation at low temperatures; and its loading is 24 watts.

## OPERATION

12. The direction of travel of the ram depends upon the energizing of one of two field circuits. The amount of travel in each direction is controlled by a pair of limit switches connected in series to provide a safety factor.

13. Consider, then, the ram to be fully retracted; and the extend field is now energized. The ram will travel forward until the shouldered section of the ram engages with the forward pair of switches

**RESTRICTED**

and opens them. This will give the position of maximum extension. On energizing the retract field, the sequence will be reversed. Movement of the ram backwards will continue until the other pair of switches are in contact with the ram. When they become operated, this will be the position of maximum retraction.

#### INSTALLATION

14. The actuators will operate satisfactorily in any position. For details of a particular installation, reference should be made to the relevant Aircraft Handbook.

#### SERVICING

15. This actuator should be serviced in accordance with the general chapter in A.P.4343, Vol. 1, Sect. 17, Chap. 1, and the instructions contained in the relevant Servicing Schedule.

#### Brushgear

16. The minimum length beyond which brushes should not be used is 0.25 in. Brushes should be renewed at periods prescribed in the relevant Servicing Schedule, and whenever examination reveals that they will not remain serviceable for the period that must elapse before the next servicing.

17. Brush spring pressure, measured with a tension gauge (Ref. No. 1H/59), should be between 5 and 7 oz. (141.7 and 198.5 gm.) when the spring is level with the top of the brush box.

#### Insulation resistance test

18. The insulation resistance, when measured with a 250-volt insulation resistance tester between all live parts and the frame, should not be less than 50,000 ohms.

## Appendix 1

### ACTUATOR, ROTAX, TYPE A1301

#### LEADING PARTICULARS

<b>Actuator, Type A1301</b>	...	...	...	...	<i>Ref. No. 5W/293</i>
<i>Voltage</i>	...	...	...	...	<i>28V d.c.</i>
<i>Current at 300 lb. load</i>	...	...	...	...	<i>3.4 amp.</i>
<i>Heater coil load</i>	...	...	...	...	<i>24 watts</i>
<i>Maximum working load</i>	...	...	...	...	<i>300 lb.</i>
<i>Maximum continuous working load</i>	...	...	...	...	<i>200 lb.</i>
<i>Maximum static load</i>	...	...	...	...	<i>750 lb.</i>
<i>Time of operation at 300 lb. load</i>	...	...	...	...	<i>40 sec. max.</i>
<i>Length of stroke</i>	...	...	...	...	<i>3 in.</i>
<i>Brush grade</i>	...	...	...	...	<i>KCEG. 12</i>
<i>Minimum brush length</i>	...	...	...	...	<i>0.25 in.</i>
<i>Brush spring pressure</i>	...	...	...	...	<i>5—7 oz. (141.7—198.5 gm.)</i>
<i>Temperature range</i>	...	...	...	...	<i>—70 deg. C. to +50 deg. C</i>
<i>Maximum operational altitude</i>	...	...	...	...	<i>50,000 ft.</i>
<i>Distance between retracted centres...</i>	...	...	...	...	<i>6.593 in.</i>
<i>Distance between extended centres</i>	...	...	...	...	<i>9.593 in.</i>
<i>Weight</i>	...	...	...	...	<i>5 lb. 12 oz.</i>

**RESTRICTED**

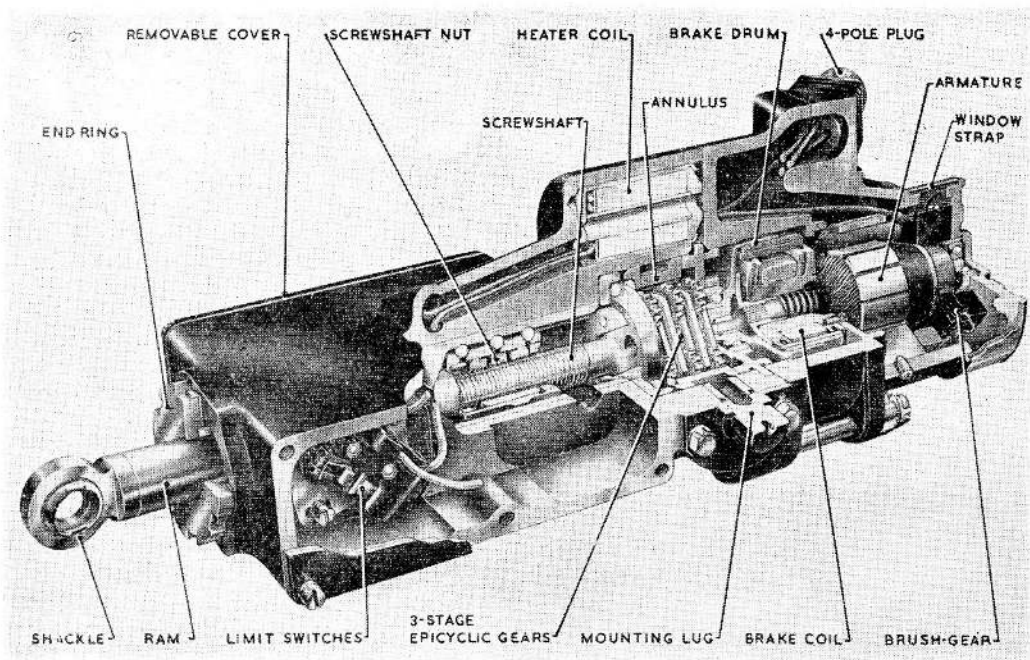

Fig. 1. Type A1301 actuator (part section)

1. This actuator is identical to that described and illustrated in the main chapter.

Electrical connection is made by means of a 4-pole plug (Ref. No. 5X/6006).

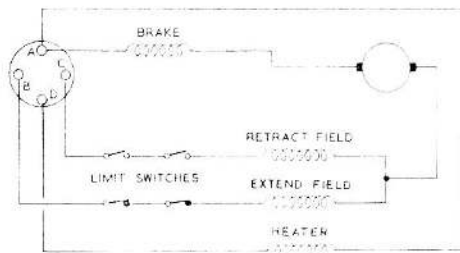

Fig. 2. Diagram of connections

## Appendix 2

### ACTUATOR, ROTAX, TYPE A1303

#### LEADING PARTICULARS

<b>Actuators, Type A1303</b>	...	...	...	...	Ref. No. 5W/2666.
<i>Voltage</i>	...	...	...	...	28V d.c.
<i>Current at 300 lb. load</i>	...	...	...	...	3.4 amp.
<i>Heater coil load</i>	...	...	...	...	24 watts
<i>Maximum working load</i>	...	...	...	...	300 lb.
<i>Maximum continuous working load</i>	...	...	...	...	200 lb.
<i>Maximum static load</i>	...	...	...	...	750 lb.
<i>Time of operation at 300 lb. load</i>	...	...	...	...	40 sec. max.
<i>Length of stroke</i>	...	...	...	...	3 in.
<i>Brush grade</i>	...	...	...	...	KCEG. 12
<i>Minimum brush length</i>	...	...	...	...	0.25 in.
<i>Brush spring pressure</i>	...	...	...	...	5—7 oz. (141.7—198.5 gm.)
<i>Temperature range</i>	...	...	...	...	—70 deg. C. to +50 deg. C.
<i>Maximum operational altitude</i>	...	...	...	...	50,000 ft.
<i>Distance between retracted centres</i>	...	...	...	...	6.593 in.
<i>Distance between extended centres</i>	...	...	...	...	9.593 in.
<i>Weight</i>	...	...	...	...	5 lb. 12 oz.

RESTRICTED

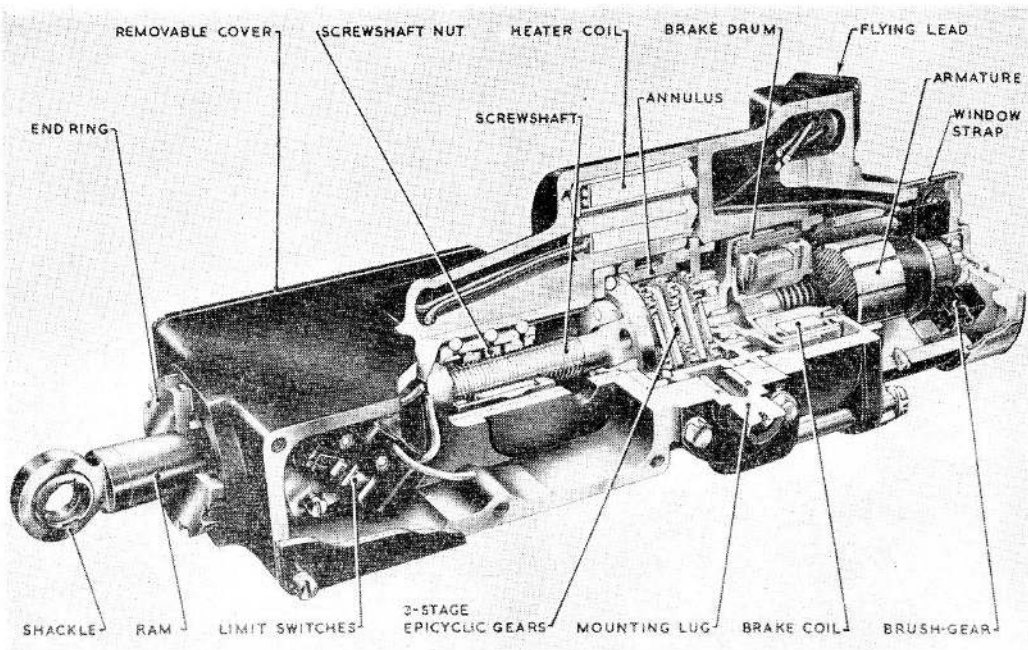

**Fig. 1. Type A1303 actuator (part section)**

1. This actuator is generally similar to that described and illustrated in the main chapter;

it differs in that electrical connection is made by a 5-core cable.

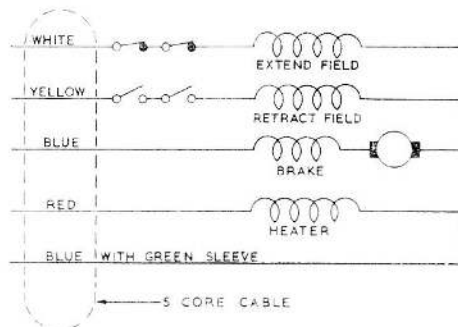

**Fig. 2. Diagram of connections**

**RESTRICTED**

This file was downloaded  
from the RTFM Library.

Link: [www.scottbouch.com/rtfm](http://www.scottbouch.com/rtfm)

Please see site for usage terms,  
and more aircraft documents.

