

## Chapter 46

### ACTUATOR, PLESSEY TYPE CZ61418/3

#### LIST OF CONTENTS

	Para.		Para.
Introduction	1	Plunger	8
Description	2	Limit switches	10
Motor	3	Installation	11
Gearbox	6	Servicing	13
Lead screw	7	Testing	
		Insulation resistance test	15

#### LIST OF ILLUSTRATIONS

	Fig.		Fig.
General view of actuator, Type CZ61418/3	1	Installation drawing of actuator	4
View of actuator without cover	2	Circuit diagram	5
Details of gearbox	3		

#### LEADING PARTICULARS

Actuator, Type CZ61418 3	Stores Ref. 5W/404
Voltage (nominal 24)	18-29V d.c.
Output of motor	0.40 h.p. at 10,000 r.p.m.
Current consumption (normal load)	3 amp.
Working load	
Normal load	300 lb.
Maximum load	400 lb.
Rating of motor	2 min.
Operating time	15 sec.
Weight	4 lb.
Travel of plunger	3.5 in.
Fixing centres retracted	9.250 in.
Fixing centres extended	12.750 in.

#### Introduction

1. The Cheetah actuator, Type CZ61418/3 is designed to provide remotely controlled, linear motion against tensile and compressive loads up to a maximum load of 400 lb.

#### DESCRIPTION

2. The actuator consists of a fractional

horse power motor, a four-stage epicyclic gearbox, and a lead screw and plunger mechanism. The length of travel of the plunger is controlled by two limit switches fitted on the plunger housing. The external supply is connected via a 5-pole plug mounted on the main casing. A general view of the actuator with the cover removed is shown in fig. 2.

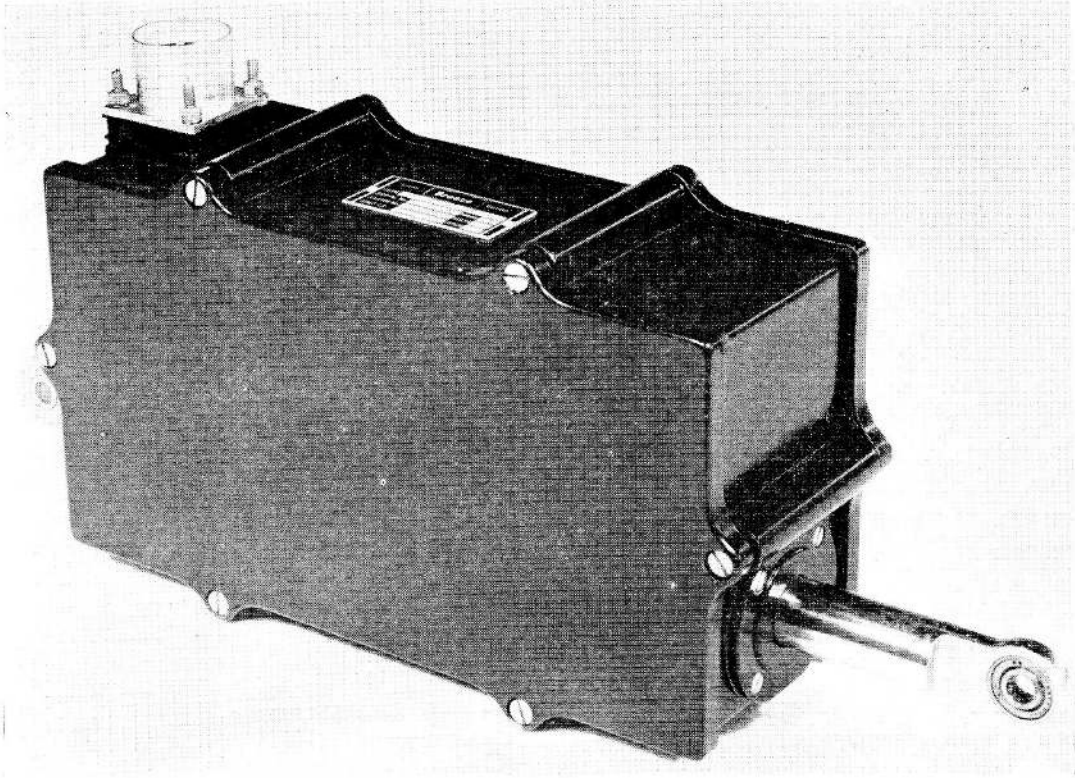

Fig. 1. General view of actuator, Type CZ61418/3

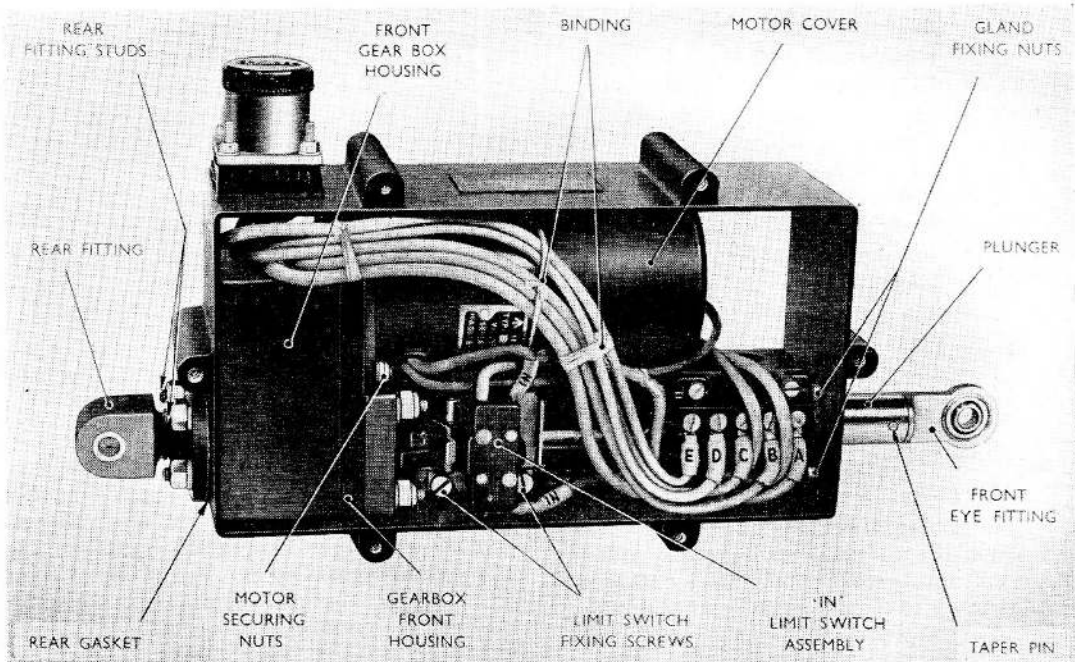

Fig. 2. View of actuator without cover

**RESTRICTED**

### Motor

3. The motor is a reversible, series wound type, designed to operate from a supply of between 18 and 29 volts (24 volts nominal). An electro-magnetic brake is incorporated in the motor unit which consists of a solenoid coil, a brake shoe assembly, a brake plate fixed to the armature shaft, and a helical spring. The solenoid is connected in series with the armature and field coils, and, when the supply to the motor is switched on, the brake shoe is pulled off the brake plate by the energised solenoid and the armature is free to rotate. When the supply to the motor is switched off, the solenoid is de-energized and the brake shoe is forced, by the helical spring, against the brake plate and the rotation of the armature arrested.

4. Two carbon brushes are mounted on a moulded rocker. The brush assembly is retained by two screws which pass through slots in the rocker, and screw into two shaped clamp plates located in a curved track behind the rocker slots. The slots permit the mechanical adjustment of the rocker to enable equal armature speeds to be obtained in both directions of rotation.

5. The motor pinion at the end of the armature shaft, meshes with the final gear. The armature is supported in two ball races which are a selected fit on the shaft.

### Gearbox

6. The gearbox consists of a front and rear housing with pinion gears mounted on ball races inset in the front and rear housings. The housings are lined up by two dowel pins on the rear housing which locate in holes in the front housing. The final gear is a sliding fit on the lead screw and is secured in position on the screw by a circular nut. Torque is transmitted from the final gear to the lead screw through a pin which is a forced fit in the shank portion of the

screw. The lead screw is supported by a thrust bearing, inset in the front housing of the gearbox. Details of the gearbox are shown in fig. 3. The gearbox is lubricated with low temperature grease during assembly and no further lubrication is necessary between overhaul periods.

### Lead screw

7. The lead screw is threaded along its main length with a  $\frac{3}{8}$  in. diameter  $\times$  12 t.p.i. Acme thread. The thread is ground to special limits and is a close mating fit with the plunger.

### Plunger

8. The plunger consists of two parts: the plunger tube and the eye end which are screwed and pinned together. The plunger is threaded internally at one end with an Acme thread which mates with the thread of the lead screw. At the other end it is

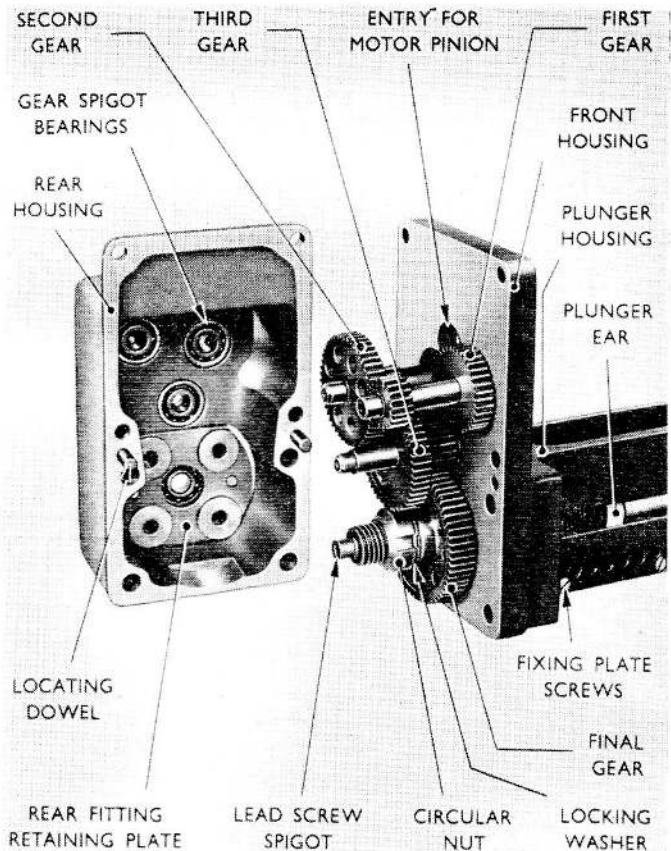

Fig. 3. Details of gearbox

threaded externally to accommodate the eye fitting. Two diametrically opposite ears are formed on the external diameter of the plunger. When the actuator is operating, the ears run in slots in the plunger housing and prevent the plunger from turning with the lead screw. These ears also operate the limit switches.

9. The plunger operates in a housing which is secured to the gearbox by four 2 B.A. screws and nuts. A row of holes is positioned along each side of the plunger housing to accommodate the fixing screws of the limit switches.

#### Limit switches

10. The limit switches are single-pole, two-way micro switches riveted to a special mounting plate. The mounting plate is secured to the plunger housing by two fixing screws and the position of the switches can be varied by fitting the screws in different fixing holes. A special rig is required for the correct setting of the limit switches and the position of the switches must not be

altered unless full instructions and facilities are available for the adjustment necessary in the correct functioning of the actuator.

#### INSTALLATION

11. For details of the installation of the actuator, reference should be made to the relevant Aircraft Handbook. When fitting an actuator, check that it is set to the correct travel for the particular installation in which it is being used. Couple the rear end of the actuator to the fixed fork end of the installation. Couple the front eye end, ensuring that the eye enters the fork on the associated load with force having to be applied to the side of the fork.

12. After the actuator has been installed, carry out several cycles of operations to ensure that the actuator functions freely.

#### SERVICING

13. After the actuator has been installed, apply a smear of approved grease to the pivot pins at each end of the actuator. The

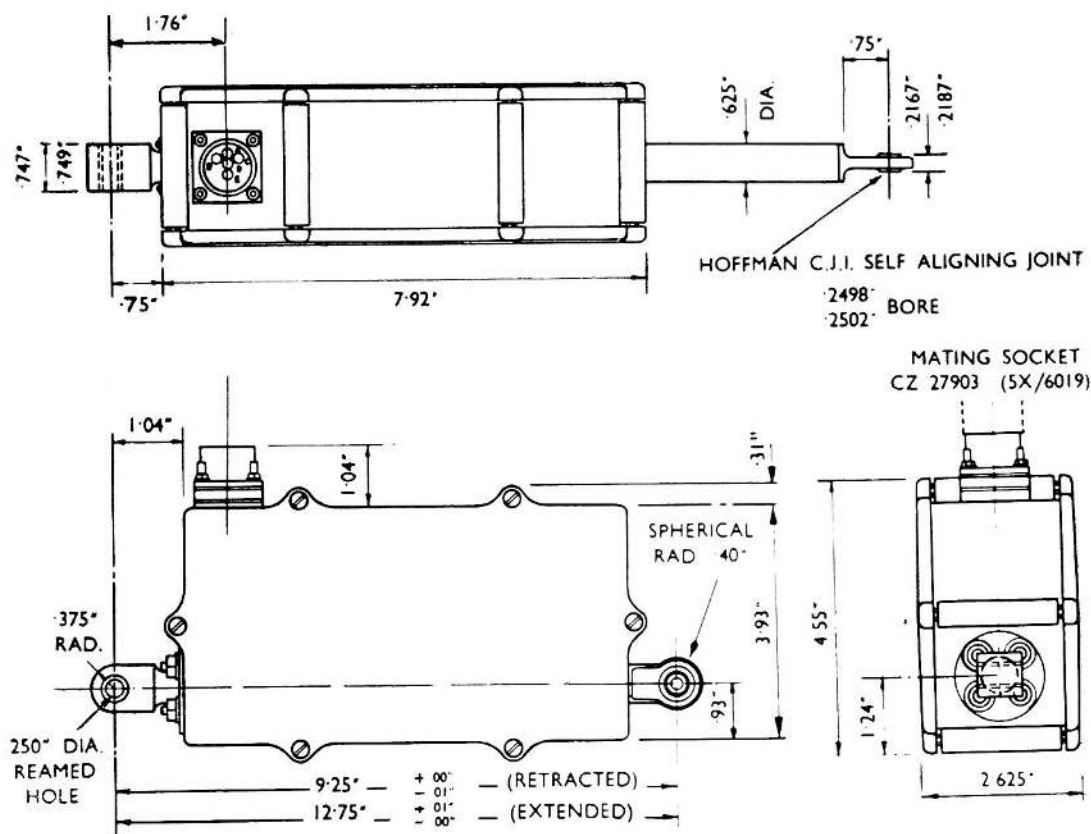

Fig. 4. Installation drawing of actuator

RESTRICTED

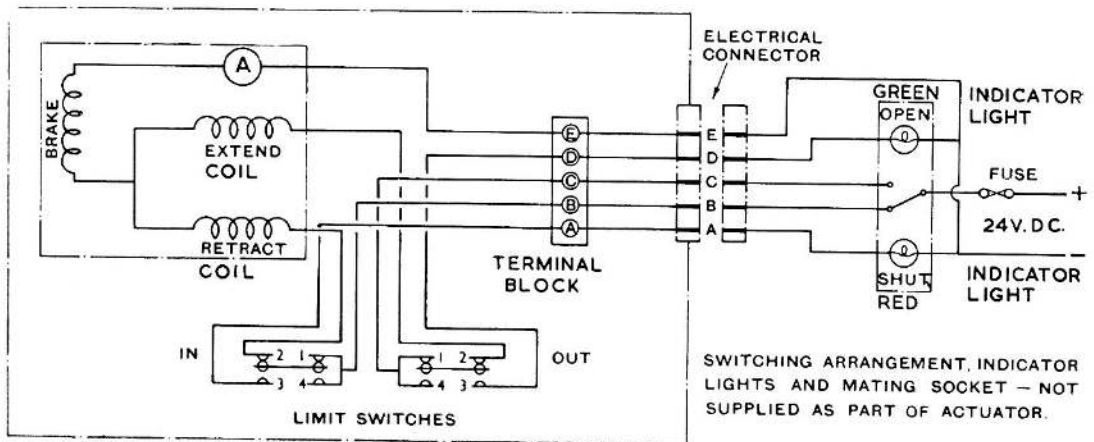

Fig. 5. Circuit diagram

machine is fully lubricated during overhaul and requires no internal re-lubrication during its overhaul life.

14. During routine inspection, check that the external screws and the actuator mounting are secure. Check the security of the plug connection.

### TESTING

#### Insulation resistance test

15. With the actuator installed in the aircraft, an insulation resistance test can be effected at the Breeze plug. Using a 250 volt insulation resistance tester, test between the electrical circuit and earth. The insulation resistance must not be less than 50,000 ohms.

This file was downloaded  
from the RTFM Library.

Link: [www.scottbouch.com/rtfm](http://www.scottbouch.com/rtfm)

Please see site for usage terms,  
and more aircraft documents.

