

Chapter 52

ACTUATORS, ROTAX, A0500 SERIES

LIST OF CONTENTS

	<i>Para.</i>		<i>Para.</i>
<i>Introduction</i>	1	<i>Limit switches</i>	15
Description	3	<i>Operation</i>	16
<i>Motor</i>	4	Installation	17
<i>Brake and clutch</i>	5	Servicing	19
<i>Gearbox</i>	7	<i>Brushgear</i>	20
<i>Ram and screwshaft</i>	9	<i>Testing</i>	22

LIST OF ILLUSTRATIONS

	<i>Fig.</i>
<i>Typical A0500 series actuator</i>	1
<i>Typical circuit diagram</i>	2

LIST OF APPENDICES

	<i>App.</i>
<i>Standard serviceability test for actuators, Rotax, A0500 series</i>	A
<i>Actuator, Rotax, Type A0513</i>	1
<i>Actuator, Rotax, Type A0514</i>	2
<i>Actuator, Rotax, Type A0515</i>	3

RESTRICTED

Introduction

1. Linear actuators in the A0500 series are intended for use in aircraft having a 28 volt d.c. supply. These units are used for jettison fuel control purposes and will operate the associated equipment at loads up to a maximum emergency load of 2,200 lb. having a ram travel of $3\frac{1}{2}$ inches. They will operate satisfactorily at altitudes up to 50,000 ft. and at temperatures ranging from -40 deg. C. to $+90$ deg. C.

2. The ram is operated over the full stroke and controlled by snap action limit switches which are provided to break the motor circuit, and simultaneously stop the ram at the end of the permitted travel. An electromagnetic brake, incorporating a single plate friction drive, is fitted to lock the ram and minimize the over-run at the end of the stroke.

DESCRIPTION

3. The actuator (fig. 1) is of 'in-line' construction, the motor, gearbox, ram, and fixing shackles having the same common axis. The single four pole plug for electrical connection is offset from the main axis, but on a line parallel to it. The mechanism is enclosed by three housings, the motor hous-

ing, an intermediate housing containing the brake and clutch, and the ram housing, containing the ram, screwshaft, gearbox, and limit switches.

Motor

4. The motor is a split field, series wound machine, one field winding being used for anti-clockwise rotation to extend the ram, and the other for clockwise rotation to retract the ram. The armature is carried by a ball bearing at the commutator end, and at the drive end, by an oil impregnated bearing in the brake drum. The brushgear is enclosed by a removable cover band so that access can readily be gained to inspect the brushes.

Brake and clutch

5. The brake coil (fig. 2) is wound on a soft iron core having four 'webs'. Each web has a spring loaded brake shoe with cork surface that presses outwards on the inner surface of the brake drum, when the coil is de-energized. The brake drum is carried in a ballrace fitted to the intermediate housing.

6. The drive end of the armature shaft extends through the bore of the brake spider, and is carried by an oil impregnated bearing

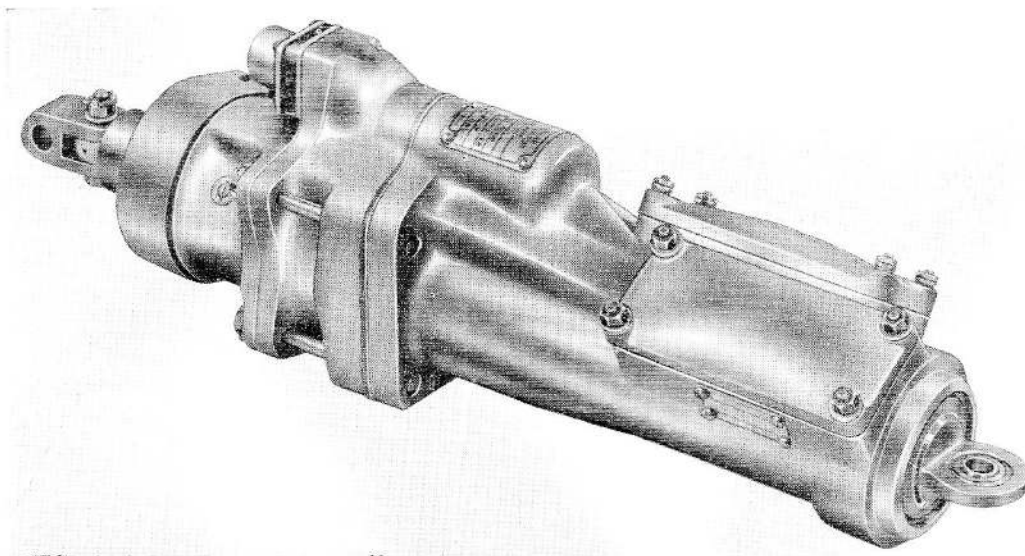

Fig. 1. Typical A0500 series actuator

RESTRICTED

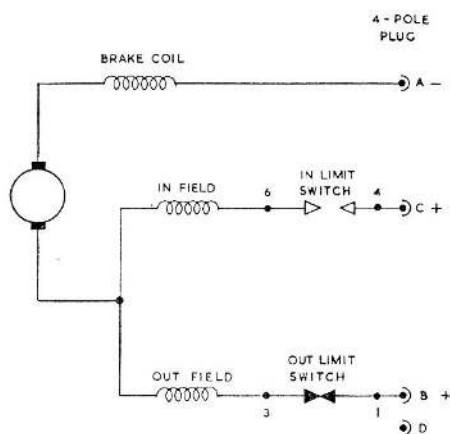

Fig. 2. Typical circuit diagram

in the brake drum. Torque is transmitted from armature to brake drum, via a single plate clutch which makes a friction drive with the inner face of the brake drum, being loaded by a helical spring on the shaft. The clutch plate has a sleeve which fits on the armature shaft and engages the shaft driving pin. The clutch is provided to absorb inertia of the armature when the motor is switched off. Simultaneously the brake is applied to minimize over-run of the ram.

Gearbox

7. The gearbox is of four stage epicyclic construction, the second, third, and fourth internal annulus gears being integral with each other. The annulus gear frame is assembled between the intermediate and ram housings, secured by four external lugs integral with the flange. The first integral annulus gear has evenly spaced special wide pitch teeth machined externally, and standard spur gear teeth generated internally. It is mounted by means of two cup and cone bearings, each containing fifty nine $\frac{3}{8}$ inch dia. balls, located between the intermediate bearing housing and the end of the annulus frame, and is free to rotate on types fitted with a release mechanism. Other actuators have the annulus gear locked in position and the release mechanism is not fitted.

8. First, second and third planetary gear trains each comprise three pinions mounted on studs and retained by a securing plate

and countersunk screws to their associated planet carriers, integral with which are the second, third and fourth sungears respectively. The fourth planet train is secured in the same manner to a flange directly on the end of the screwshaft. All the planet assemblies are aligned correctly by bosses machined on the sungear flange and located in a plain bearing in each successive planet assembly. In the first planet train, a spring loaded ball replaces the plain bearing and serves to load the planet assemblies axially.

Ram and screwshaft

9. The screwshaft is of hardened steel with an accurately ground semi-circular helical groove running down its entire length. Integral with one end of the screwshaft is a driving flange having a conical ground ball track on the circumference with three planet gear studs machined on the driven face. The conical flange is supported by two cup and cone bearings composed of two sets of forty two, $\frac{1}{8}$ in. diameter steel balls, and two outer races, one being machined in the annulus frame and the other in a steel liner fitted in the ram housing.

10. The ram, also of hardened steel, has a corresponding semi-circular ground helical groove formed internally at one end, and acts as a ball nut to the ram, the groove extending for two complete turns only.

11. Motion between the two components is transferred by steel balls which run in the ball track formed by the two grooves. The balls are divided into circular rows by deflectors fitted across each complete turn of the groove of the nut.

12. During operation the deflectors serve to divert the balls from the end of each turn to the start of the same turn, thus providing a re-circulating path for each row.

13. Rotary motion of the screwshaft imparts linear motion to the ram through the action of the re-circulating ball nut. Supporting the ram are two sets of steel balls located in key seats in the outer surface of the ram; these run in steel guides cast in the ram housing. This arrangement provides an almost frictionless type bearing for the linear

RESTRICTED

motion of the ram, in addition to maintaining the ram true in the housing and off setting the torque re-action from the screw-shaft.

14. In the groove in the front end of the ram housing is fitted a Neoprene seal flanked by two circlips, the seal being provided for the exclusion of dust and oil, and the circlips for retaining the seal and preventing the ram from being completely removed from the housing, when fully extended. Machined slots in the surface of the ram are provided for operation of the IN and OUT limit switches respectively, when the ram has reached its fully retracted or extended position. The ram carries a fixing shackle having a self aligning joint.

Limit switches

15. The two moulded snap action limit switches are secured by three screws, each in separate compartments in the ram housing, and the securing holes in the base plates are suitably slotted to allow adjustment of the switches to give correct extended and retracted lengths of the actuator.

Operation

16. On connecting the appropriate pole of the four-pole plug to positive (pole B to extend, pole C to retract) and pole A to negative (pole D+ is not used), a circuit is completed through the limit switch contacts, motor field, armature and brake coil. The brake shoes are pulled in to release the brake drum and the motor begins to rotate. The rotary motion of the motor is transmitted, via the epicyclic gear box, to the screwshaft, where the rotary motion is transformed into the linear motion of the ram by the recirculating ball thread. The ram extends or retracts until either the supply is switched off, or the ram reaches the end of its travel, where the motor circuit is broken by the limit switch. In either instance the brake coil is immediately de-energized, and the brake shoes being released, lock the brake drum, via the mechanical action of the springs retained in the solenoid webs. The actuator therefore comes quickly to rest, the momentum or, kinetic energy of the

armature being dissipated through the single plate clutch so that the ram over-run is reduced to a minimum.

INSTALLATION

17. Two shackles are fitted, one moving with the ram, having a 0.312 in. diameter bore self-aligned bush (Hoffman type C.J.2.) and one fitted to the end of the motor housing, this has a forked shackle bolted to it, with a 0.375 + .001 in. diameter reamed hole for connection to the associated equipment.

18. Electrical connection is made via a single 4-pole Breeze plug (Ref. No. 5X/6006).

SERVICING

19. These actuators should be serviced in accordance with the general information in A.P.4343, Vol. 1, Sect. 17, Chap. 2, and the instructions contained in the relevant Servicing Schedule.

◀ Brushgear

20. The minimum length beyond which brushes should not be used is 0.281 in., the measurement being taken over the long edge. Brushes should be renewed at periods prescribed in the relevant Servicing Schedule, and whenever examination reveals that they will not remain serviceable for the period that must elapse before the next servicing.

21. Brush spring pressure should be measured with a tension gauge (Ref. No. 1H/59), the reading being taken from the point where the spring bears on the bush. The correct pressure is between 2½ oz. and 3 oz. (71 and 85 gm.).

Testing

22. If the serviceability of the machine is suspect, it may be tested as laid down in Appendix A. ▶

RESTRICTED

Appendix A

STANDARD SERVICEABILITY TEST FOR ACTUATORS, ROTAX, A0500 SERIES

Introduction

1. The following tests may be applied to the machine before it is put into service or at any time when its serviceability is suspect.

Test equipment

2. The following test equipment is required:—

- (1) Tension gauge (Ref. No. 1H/59).
- (2) Linear actuator test rig (Ref. No. 4G/5420).
- (3) Insulation resistance tester, Type C (Ref. No. 5G/152).

Testing

Brushgear

3. Check the brush length and brush spring pressure; the brush length should be not less than 0.281 in. and the spring pressure should be between $2\frac{1}{2}$ and 3 oz. (71 and 85 gm.).

Performance test

4. Set the actuator on the test rig and ensure that it operates within the limits given in Table A and Table B, for supply voltages of 24V and 28V respectively.

TABLE A

Load	Maximum	
	current at 24V (amp.)	time for full travel (sec.)
Emergency 2,200 lb. (max.)	7.0	70
Working 1,500 lb. (max.)	4.75	38
Normal working 750 lb.	4.5	26
Free run — no load	3.5	21

TABLE B

Load	Maximum	
	current at 28V (amp.)	time for full travel (sec.)
Emergency 2,200 lb. (max.)	6.0	35
Working 1,500 lb. (max.)	4.8	27
Normal working 750 lb.	3.6	19.5
Free run — no load	2.4	14

Insulation resistance test

5. The insulation resistance, when measured with a 250-volt insulation resistance tester between all live parts and the frame, should not be less than 0.05 megohm.

RESTRICTED

Appendix 1

ACTUATOR, ROTAX, TYPE A0513

LEADING PARTICULARS

Actuator, Rotax, Type A0513	Ref. No. 5W/3556
<i>Voltage</i>	24—29V d.c.
<i>Normal load</i>	750 lb.
<i>Maximum working load</i>	1,500 lb.
<i>Maximum emergency load</i>	2,200 lb.
<i>Maximum static load</i>	5,000 lb.
<i>Current for normal load on 24V</i>	4.5 amp.
<i>Length of stroke</i>	3.5 in.
<i>Maximum time of stroke at normal load on 24V</i>	26 sec.
<i>Rating</i>	6 minutes (max.)
<i>Operational ceiling</i>	50,000 ft.
<i>Operational temperature range</i>	—40 deg. C. to +90 deg. C.
<i>Overall dimensions—</i>	
<i>Length (extended)</i>	17.750 + 0.020 in. — 0
<i>Length (retracted)</i>	14.250 + 0 in. — 0.020
<i>Width</i>	3.000 in.
<i>Height</i>	3.968 in.
<i>Brush grade</i>	D.M.4A.H.A.M.
<i>Brush length (new)</i>	0.390 ± 0.010 in.
<i>Brush length (minimum)</i>	0.281 in.
<i>Brush spring pressure</i>	2.5 to 3.0 oz. (71 to 85 gr.)
<i>Commutator diameter (new)</i>	0.718 + 0 in. — 0.005
<i>Commutator diameter (minimum permissible)</i>	0.680 in.

1. The actuator, Type A0513, is identical to that described and illustrated in the main chapter.

RESTRICTED

Appendix 2

ACTUATOR, ROTAX, TYPE A0514

LEADING PARTICULARS

Actuator, Rotax, Type A0514	Ref. No. 5W/983
<i>Voltage</i>	24—29V d.c.
<i>Normal load</i>	750 lb.
<i>Maximum working load</i>	1,500 lb.
<i>Maximum emergency load</i>	2,200 lb.
<i>Maximum static load</i>	5,000 lb.
<i>Current for normal load on 24V</i>	4.5 amp.
<i>Length of stroke</i>	3.5 in.
<i>Maximum time of stroke at normal load on 24V</i>	26 sec.
<i>Rating</i>	6 minutes (max.)
<i>Operational ceiling</i>	50,000 ft.
<i>Operational temperature range</i>	-40 deg. C. to +90 deg. C.
<i>Overall dimensions—</i>	
<i>Length (extended)</i>	17.750 + 0.020 in. - 0
<i>Length (retracted)</i>	14.250 + 0 in. - 0.020
<i>Width</i>	3.000 in.
<i>Height</i>	3.968 in.
<i>Brush grade</i>	<i>D.M.4A.H.A.M.</i>
<i>Brush length (new)</i>	0.390 ± 0.010 in.
<i>Brush length (minimum)</i>	0.281 in.
<i>Brush spring pressure</i>	2.5 to 3.0 oz. (71 to 85 gr.)
<i>Commutator diameter (new)</i>	0.718 + 0 in. - 0.005
<i>Commutator diameter (minimum permissible)</i>	0.680 in.

1. The A0514 actuator is identical to that described and illustrated in the main chapter, except that the fixed shackle is turned through 90 degrees.

RESTRICTED

This file was downloaded
from the RTFM Library.

Link: www.scottbouch.com/rtfm

Please see site for usage terms,
and more aircraft documents.

