

## Chapter 57

## ACTUATORS, PLESSEY, CUB-JAGUAR SERIES

## LIST OF CONTENTS

	<i>Para.</i>		<i>Para.</i>
<i>Introduction</i> ... ..	1	<b>Operation</b> ... ..	18
<b>Description</b>		<b>Installation</b> ... ..	20
<i>General</i> ... ..	4	<b>Servicing</b>	
<i>Motor</i> .. ... ..	5	<i>General</i> ... ..	23
<i>Reduction gear train</i> ... ..	7	<i>Bay servicing</i> ... ..	24
<i>Leadscrew and plunger</i> ... ..	9	<i>Brushgear</i> ... ..	25
<i>Limit switches and operating mechanism</i> ... ..	11	<i>Lubrication</i> ... ..	28
<i>Electrical connections</i> ... ..	15	<i>Re-assembling the actuator</i> ... ..	29
<i>End fittings</i> ... ..	17	<i>Testing</i> ... ..	3i

## LIST OF ILLUSTRATIONS

	<i>Fig.</i>		<i>Fig.</i>
<i>General view of Cub Jaguar actuator</i>	1	<i>Limit switch operating mechanism</i> ...	3
<i>Sectional view of Cub Jaguar actuator</i>	2	<i>Typical circuit diagram</i> ... ..	4

## LIST OF APPENDICES

	<i>App.</i>		<i>App.</i>
<i>Standard serviceability tests</i> ... ..	A	<i>Actuators, Plessey, Types 1CZ82360 variants</i> ... ..	4
<i>Actuators, Plessey, Type 1CZ135840/B/- variants</i> ... ..	1	<i>Actuators, Plessey, Types 500/1/00640 variants</i> ... ..	5
<i>Actuators, Plessey, Type 1CZ80360 variants</i> ... ..	2	<i>Actuators, Plessey, Types 500/1/00370 variants</i> ... ..	6
<i>Actuators, Plessey, Types 1CZ82950/1 and 1CZ136410/2</i> ... ..	3	<i>Actuators, Plessey, Types 500/1/01320 variants</i> ... ..	7

RESTRICTED

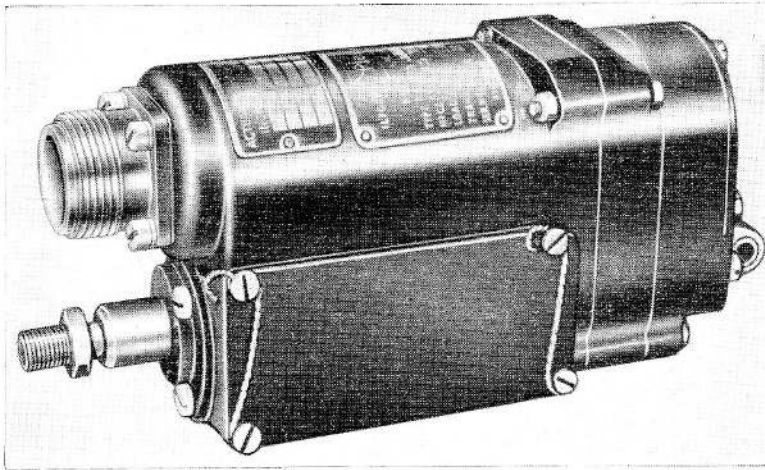

**Fig. 1. General view of Cub Jaguar actuator**

## Introduction

1. The Cub Jaguar series of actuators are designed to provide remotely-controlled linear motion against tensile or compressive loads.

2. Basically, the actuators consist of a reversible motor which drives a leadscrew, threaded into a plunger, through a multi-stage reduction gear train. The travel of the plunger is controlled by two limit switches which are operated by the plunger through an adjustable switch-operating mechanism. Electrical connections to the actuator are made through either a plug or a ferrule outlet and cable in the front of the casing. An end fitting screwed on to the plunger provides one attachment point, the other being an end fitting secured to the rear of the casing.

3. Variants in this series differ in their plunger travel, electrical connections, end fittings, reduction gear ratio and minor internal changes. Details of these variants will be found in the appendices to this chapter.

## DESCRIPTION

### General

4. A general view of a typical Cub Jaguar

actuator is shown in Fig. 1, and a unit in this series is shown sectioned in Fig. 2.

### Motor

5. The motor is a series wound, split field type, to permit reversible operation. The armature is supported in two ball bearings, one located in the drive-end housing, and the other in the commutator-end housing. The housings are secured to the yoke by through-studs, screwed into the drive-end housing, and the assembly is secured by two nuts at the commutator - end. The brushgear is secured to the commutator-end housing and, for the purpose of adjustment, the housing assembly can be moved radially within the limits of the two slots through which the studs pass.

6. An electro-magnetic brake is incorporated in the drive end of the motor. The brake coil is enclosed within the drive-end housing and, when energized attracts the lined brake disc away from the rear face of the brake plate. The motor pinion forms an integral part of the brake plate which is secured to the drive-end of the armature and located by a drive pin. The brake disc is prevented from rotating by two dowels in the drive-end housing and is loaded by the brake spring.

**RESTRICTED**

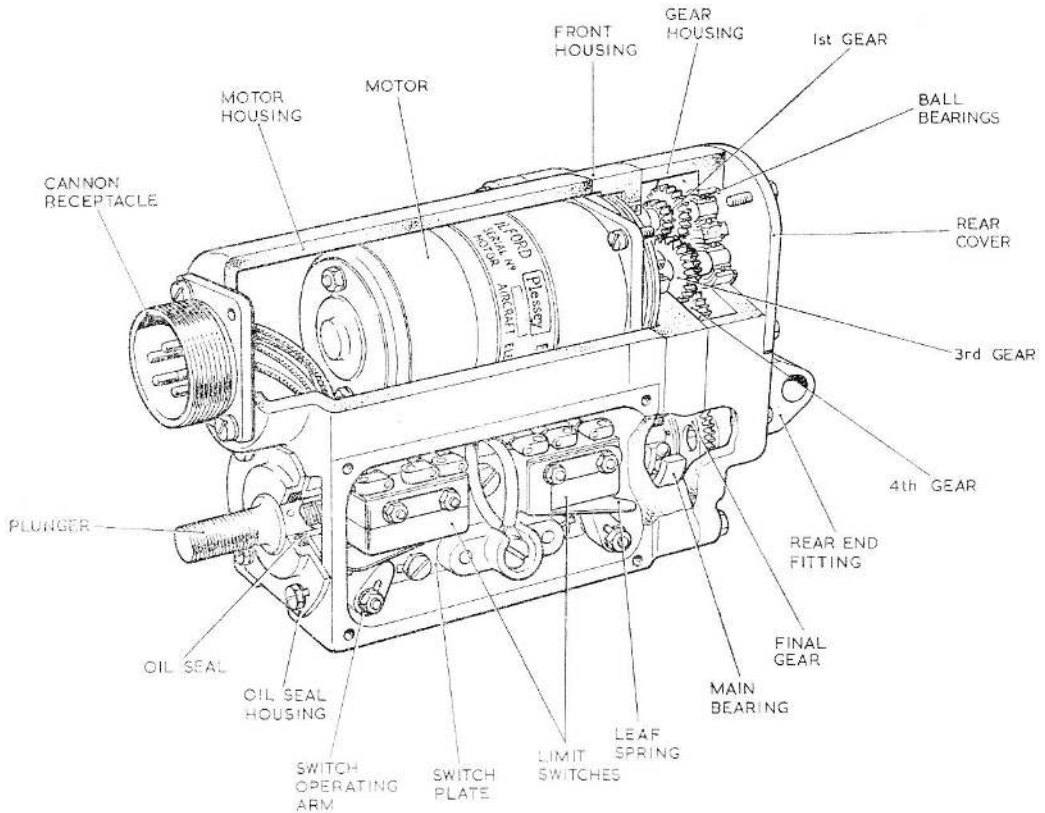

Fig. 2. Sectional view of Cub Jaguar actuator

### Reduction gear train

7. The drive from the motor pinion to the leadscrew is through a reduction gear train of five compound spur gears and a final gear. The gears are arranged to provide the required gear ratio to suit a particular variant.

8. Each gear shaft is supported in two ball bearings fitted in the two halves of the gearbox casing.

### Leadscrew and plunger

9. The 5th stage gear of the reduction gear train meshes with the final gear which is secured to the rear end of the leadscrew. An Acme thread machined on the outside of the leadscrew and in the bore of the

plunger serves to convert the rotary action of the leadscrew into linear movement of the plunger, causing it to extend or retract.

10. A large ball bearing supports the rear end of the leadscrew and plunger assembly while the front end of the assembly is supported in a plain bush. The plunger is prevented from rotating by integral torque-reaction ears which locate in slots in the actuator body. The outer end of the plunger is threaded to carry the front end fitting for attachment to the component being driven.

### Limit switches and operating mechanism

11. Plunger travel is controlled by two limit switches, mounted on one side of the

RESTRICTED

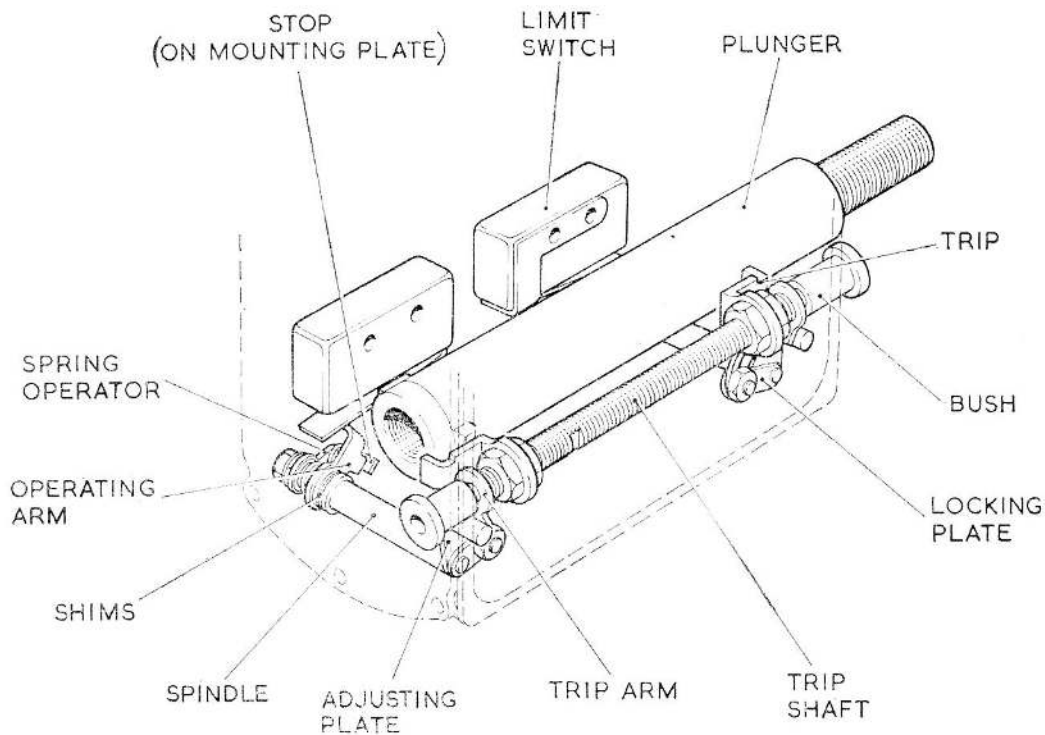

**Fig. 3. Limit switch operating mechanism**

actuator body. The switches are operated by a mechanism (*fig. 3*) which is tripped by one of the torque-reaction ears on the plunger.

**12.** At the pre-set limit of plunger travel, the torque-reaction ear comes into contact with a trip on the trip shaft, moving the shaft assembly in the same direction as the plunger. The appropriate downward-facing trip arm on the shaft assembly is then brought into contact with a dowel on the end of one of the transverse spindles, causing the spindle to rotate. An operating arm fitted to the switch end of the spindle is then brought up under the switch leaf spring to depress the limit switch plunger and so cut off the power supply to the motor.

**13.** In the later versions of the switch operating mechanism, as shown in *Fig. 3*, an adjusting plate is fitted to the trip-shaft end of each transverse spindle to permit adjustment for eliminating backlash. Also, at the limit switch end of the spindles, the

drive is transmitted to the operating arms through a spring operator (fitted to the end of each spindle) and a torsion spring, to prevent damage to the limit switches if the movement of the operating arm is excessive.

**14.** Adjustment of the plunger travel is made by altering the position of the trips on the threaded trip shaft, so that the torque-reaction ear on the plunger contacts them earlier or later.

#### **Electrical connections**

**15.** The electrical connections to the actuator can be made through either a plug or a ferrule outlet and cable in the front of the actuator body. The method used varies with the actuator type.

**16.** The internal connections and a typical external circuit are shown in *Fig. 4*. In this example, connections are provided for a position indicator.

**RESTRICTED**

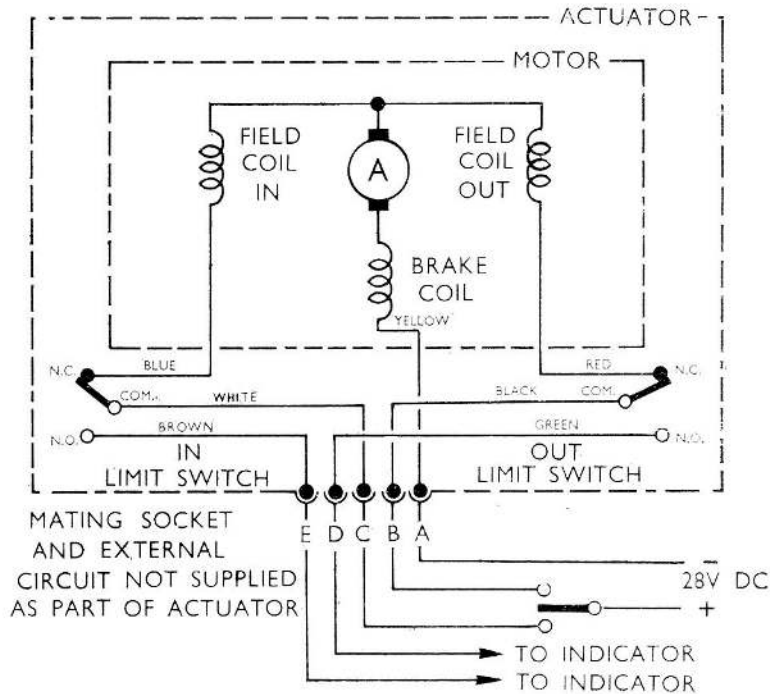

Fig. 4. Typical circuit diagram

### End fittings

17. The rear end fitting is spigotted into the gear housing and is secured by screws. The front end fitting is screwed on to the front of the plunger and locked by a lock-nut. The types of end fittings used vary with the actuator type.

### OPERATION

18. The motor rotates the leadscrew through the reduction gear train and the final gear. The plunger, being threaded on to the leadscrew, is caused to extend or retract when the leadscrew is rotated and is itself prevented from rotating by two integral torque-reaction ears which locate in slots in the actuator body.

19. At the extremes of plunger travel, the contacts in one of the limit switches are opened by the switch operating mechanism, thereby cutting off the power supply to the

motor; the brake incorporated in the motor prevents excessive overrun of the plunger. The reverse rotation is achieved by selecting the alternative position on the external control switch.

### INSTALLATION

20. For details of an actuator installation in a particular aircraft, reference should be made to the appropriate aircraft Air Publication.

21. When fitting a new or overhauled unit, first check that the actuator is of the correct type for the installation; no adjustments should be made to the plunger travel except when the actuator is fitted to the Linear actuator test rig. Check that the actuator has not been damaged in transit, that all external screws, nuts and bolts are fully tightened, and that the necessary fittings are available for securing the actuator to its associated

**RESTRICTED**

component. Ensure that the plunger of the actuator and the drive shaft of the associated component are correctly positioned before coupling them together.

22. After the actuator has been installed, check the security of the installation and operate the actuator to ensure that it functions correctly.

## SERVICING

### General

23. Routine servicing of the installed actuator consists of examinations for security of mounting, serviceability of electrical connections and signs of damage or deterioration. At intervals prescribed in the relevant Aircraft Servicing Schedule the actuator is removed for bay servicing.

### Bay Servicing

24. On removal from an aircraft the actuator should be cleaned externally and examined for signs of damage or corrosion. It should then be dismantled to the extent necessary to enable bearings to be cleaned, examined and lubricated; for brushgear and commutator to be cleaned and examined and for new brushes to be fitted and bedded.

### Brushgear

25. Access to the brushgear may be gained after partially dismantling the actuator as follows; Fig. 1, 2 and 3 of the main chapter refer.

- (1) Check that the plunger is clear of both limit switches, then slacken the locknut and remove the front end fitting.
- (2) Remove the two side plates (four screws each).
- (3) Cut the thread binding the leads, note the position and identity of the tags on the limit switches, then unsolder the motor tags. These are attached to the switch terminals nearest to the centre of the actuator, the Red lead to the left side switch and the Blue to the right side switch. Remove the screw

from the central moulded terminal to release the Yellow negative lead.

(4) Turn the actuator over and unscrew the nuts holding the trip arm nearer the gearbox. Run the inner nut towards the centre and lift the trip arm out of the slot in the housing (a dimple in the trip shaft, shown in fig. 3 is provided for this purpose).

(5) Remove the four bolts surrounding the rear end fitting and also the special nut and bolt underneath.

(6) Slacken the nuts as far as possible on the two upper bolts (which pass through the web of the motor housing (near the label in fig. 1), using two spanners. Crack the actuator at the gasket between the front housing and the gearbox and ease apart unscrewing the two nuts until they fall clear. The gearbox complete with motor and plunger can then be withdrawn from the motor housing.

26. All traces of carbon dust should be removed from the commutator and brushgear using compressed air. New brushes should be fitted at the intervals prescribed in the bay servicing schedule and whenever examination reveals that they may reach the minimum length before the next servicing. The new brushes should slide freely in their holders without excessive clearance and the spring pressure should be within  $3\frac{1}{2}$  to  $4\frac{1}{2}$  oz. measured with a tension gauge, with the tip of the spring level with the top of the brush holder.

27. Information on brush bedding is contained in A.P.4343, Vol. 1, Sect. 1, Chap. 2. The final bedding is accomplished by running the motor from a 12V supply on no load for half-hour periods in each direction of rotation with the brake mechanism removed. The input voltage should be adjusted as necessary to ensure that the motor speed does not exceed 15,000 rev/min. The bedding run should be continued until each brush is bedded over its full thickness and at least 80% of its contact surface. Care should be taken to avoid overheating of the motor during this running. All traces of carbon dust must again be removed when the bedding is satisfactorily completed.

**RESTRICTED**

### Lubrication

**28.** Bearings should be cleaned with lead-free gasoline or white spirit to remove old grease and foreign matter. Dry compressed air should be used to dry the bearings, care being taken to avoid spinning the races by the air jet. Serviceable bearings should be regreased immediately after drying by pressing grease, XG-275 between the inner and outer races for a distance of one-third of their circumference and rotating the bearings by hand to distribute the grease evenly over the tracks.

### Re-assembling the actuator

**29.** On completion of the lubrication, the gearbox and motor assembly complete with the plunger should be replaced in the motor housing and secured with the appropriate nuts and bolts. The front end fitting and locking nut should be replaced on the plunger thread and secured so that the nut is positioned 0.10 in. from the end of the plunger. The connections to the limit switch tags

should be resoldered and the two negative leads secured to the central terminal.

**30.** The trip arm should be refitted in its slot in the motor housing and locked by the two nuts in approximately its original position on the plunger screw. The two side plates should not be replaced until testing is completed and any necessary adjustments have been made.

### Testing

**31.** The insulation resistance of the actuator should be measured with a 250V insulation resistance tester connected between the framework of the machine and each cable in turn. A minimum value of 50,000 ohms should be obtained.

**32.** The actuator should then be mounted on the Linear actuator test rig (Ref. No. 4G/5420) in accordance with the instructions contained in A.P.4343S, Vol. 1, Book 2, Sect. 8, Chap. 3 and tests made as detailed in the Standard Serviceability Tests at Appendix A.

**TABLE 4**  
Testing details for Cub-Jaguar actuators, type 500/1/00640/002

Applied voltage	Load (lb)	Condition of load	Time in seconds for 2 in. stroke		Maximum current (Amp.)	Stroke tolerance
			(Min.)	(Max.)		
29	100	C.L.O.	14.0	19.2	1.35	
29	100	C.L.A.	13.0	17.8	1.20	- 0.020 in.
29	100	T.L.O.	14.0	19.2	1.35	
29	100	T.L.A.	13.0	17.8	1.20	+ 0.020 in.
29	0	Extend	12.6	17.0	1.15	
29	0	Retract	12.6	17.0	1.15	
24	0	Extend	14.8	20.0	1.10	
24	0	Retract	14.8	20.0	1.10	

**TABLE 5**  
Testing details for Cub-Jaguar actuator, type 1CZ.82950/1

Applied voltage	Load (lb)	Condition of load	Time in seconds for 1.08 in. stroke		Maximum current (Amp.)	Stroke tolerance
			(Min.)	(Max.)		
29	100	T.L.O.	7.6	10.4	1.35	+ 0.020 in.
29	100	T.L.A.	7.0	9.6	1.20	
29	100	C.L.O.	7.6	10.4	1.35	- 0.020 in.
29	100	C.L.A.	7.0	9.6	1.20	

**TABLE 6**  
Testing details for Cub-Jaguar actuator, type 1CZ/136410/2

Applied voltage	Load (lb)	Condition of load	Time in seconds for 2 in. stroke		Maximum current (Amp.)	Stroke tolerance
			(Min.)	(Max.)		
29	100	T.L.O.	14.0	19.2	1.35	+ 0.020 in.
29	100	T.L.A.	13.0	17.8	1.20	
29	100	C.L.O.	14.0	19.2	1.35	- 0.020 in.
29	100	C.L.A.	13.0	17.8	1.20	

**RESTRICTED**

**TABLE 7**  
**Testing details for Cub-Jaguar actuator, type 1CZ.80360/A**

Applied voltage	Load (lb)	Condition of load	Time in seconds for 2 in. stroke		Maximum current (Amp.)	Stroke tolerance
			(Min.)	(Max.)		
29	100	C.L.O.	9.2	12.0	1.80	
29	100	C.L.A.	8.0	11.20	1.55	- 0.030 in.
29	100	T.L.O.	9.2	12.0	1.80	
29	100	T.L.A.	8.0	11.20	1.55	+ 0.030 in.
18	0	Extend	11.0	14.8	1.35	
18	0	Retract	11.0	14.8	1.35	

**TABLE 8**  
**Testing details for Cub-Jaguar actuators, types 1CZ.80360/B and 1CZ.135840/B**

Applied voltage	Load (lb)	Condition of load	Time in seconds for 2 in. stroke		Maximum current (Amp.)	Stroke tolerance
			(Min.)	(Max.)		
29	100	C.L.O.	3.6	4.7	1.75	
29	100	C.L.A.	3.1	4.1	1.50	- 0.030 in.
29	100	T.L.O.	3.6	4.7	1.75	
29	100	T.L.A.	3.1	4.1	1.50	+ 0.030 in.
18	0	Extend	4.8	6.0	1.2	
18	0	Retract	4.8	6.0	1.2	

**TABLE 9**  
**Testing details for Cub-Jaguar actuators, type 500/1/00370**

Applied Voltage	Load (lb.)	Condition of load	Time in seconds for full stroke (2.00 in.)		Maximum current (Amperes)	Stroke tolerance
			Min.	Max.		
29	100	C.L.O.	9.2	12.0	1.8	
29	100	C.L.A.	8.0	11.2	1.55	+0.020 in.
29	100	T.L.O.	9.2	12.0	1.8	
29	100	T.L.A.	8.0	11.2	1.55	-0.020 in.
29	0	Extend	7.2	9.0	1.4	
29	0	Retract	7.2	9.0	1.4	
18	0	Extend	11.0	14.8	1.35	
18	0	Retract	11.0	14.8	1.35	

**TABLE 10**  
**Testing details for Cub-Jaguar actuators, Type 500/1/01320**

Applied Voltage	Load (lb.)	Condition of load	Time in seconds for full stroke (2.0 in.)		Maximum current (Amperes)	Stroke tolerance
			Min.	Max.		
29	100	T.L.O.	9.2	12.0	1.8	
29	100	T.L.A.	8.0	11.2	1.55	+0.020 in.
29	100	C.L.O.	9.2	12.0	1.8	
29	100	C.L.A.	8.0	11.2	1.55	-0.020 in.
29	0	Extend	7.2	9.0	1.4	
29	0	Retract	7.2	9.0	1.4	
18	0	Extend	11.0	14.8	1.35	
18	0	Retract	11.0	14.8	1.35	

T.L.O. Tensile load opposing  
T.L.A. Tensile load assisting

C.L.O. Compressive load opposing  
C.L.A. Compressive load assisting

**RESTRICTED**

## Appendix A

### STANDARD SERVICEABILITY TESTS PLESSEY CUB-JAGUAR ACTUATORS

#### LIST OF TABLES

	<i>Table</i>
<i>Actuator, type 1CZ.82360/A ...</i>	1
<i>Actuator, type 1CZ.82360/B ...</i>	2
<i>Actuator, type 500/1/00640/001 ...</i>	3
<i>Actuator, type 500/1/00640/002 ...</i>	4
<i>Actuator, type 1CZ.82950/1 ...</i>	5
<i>Actuator, type 1CZ.136410/2 ...</i>	6
<i>Actuator, type 1CZ.80360/A ...</i>	7
<i>Actuator, type 1CZ.80360/B and 1CZ.135840/B ...</i>	8

#### Introduction

1. The tests detailed in this appendix are intended to check the serviceability of actuators after servicing or when their serviceability is in doubt.

#### Test equipment

2. The following equipment is required:—
- (1) Tester, insulation resistance, 250V Type C (Ref. No. 5G/152).
  - (2) Test rig, Linear actuator, (Ref. No. 4G/5420).
  - (3) A direct current supply, variable between 18 and 29 volts.
  - (4) Tension gauge Mk. 3, Ref. No. 1A/56.

#### Insulation resistance test

3. The insulation resistance should be

measured between the actuator frame and each cable core. The value should not be less than 50000 ohms.

#### Functional tests

4. The actuator should be fitted to the test rig in accordance with the details contained in A.P.4343S, Vol. 1, Book 2, Sect. 8, Chap. 3 and connected to a 24V supply. The length of the stroke should be measured after the actuator is run on no load to both the extended and retracted positions and where necessary the limit switch trip levers adjusted to bring the strokes within the relevant limits. The actuator should then be operated under the various loads and input voltages shown in the appropriate table to check that its performance is within the tabulated limits. There should be no excessive vibration during the tests and the actuator should be inched in each direction to check that the brake functions satisfactorily.

RESTRICTED

**TABLE 1****Testing details for Cub-Jaguar actuators, type 1CZ.82360/A**

Applied voltage	Load (lb)	Condition of load	Time in seconds for 2.00 in. stroke		Maximum current (Amp.)	Stroke tolerance
			(Min.)	(Max.)		
29	100	C.L.O.	9.2	12.0	1.8	
29	100	C.L.A.	8.0	11.2	1.55	- 0.030 in.
29	100	T.L.O.	9.2	12.0	1.8	
29	100	T.L.A.	8.0	11.2	1.55	+ 0.030 in.
29	0	Extend	7.2	9.0	1.4	
29	0	Retract	7.2	9.0	1.4	
18	0	Extend	11.0	14.8	1.35	
18	0	Retract	11.0	14.8	1.35	

**Note:**—Load abbreviations refer to compressive or tensile, opposing or assisting.

**TABLE 2****Testing details for Cub-Jaguar actuators, type 1CZ.82360/B**

Applied voltage	Load (lb)	Condition of load	Time in seconds for 2.00 in. stroke		Maximum current (Amp.)	Stroke tolerance
			(Min.)	(Max.)		
29	50	C.L.O.	3.6	4.7	1.75	
29	50	C.L.A.	3.1	4.1	1.5	- 0.03 in.
29	50	T.L.O.	3.6	4.7	1.75	
29	50	T.L.A.	3.1	4.1	1.5	+ 0.03 in.
29	0	Extend	3.0	3.9	1.3	
29	0	Retract	3.0	3.9	1.3	
18	0	Extend	3.4	4.3	1.2	
18	0	Retract	3.4	4.3	1.2	

**TABLE 3****Testing details for Cub-Jaguar actuators, type 500/1/00640/001**

Applied voltage	Load (lb)	Condition of load	Time in seconds for 1.08 in. stroke		Maximum current (Amp.)	Stroke tolerance
			(Min.)	(Max.)		
29	100	C.L.O.	7.6	10.4	1.35	
29	100	C.L.A.	7.0	9.6	1.20	- 0.020 in.
29	100	T.L.O.	7.6	10.4	1.35	
29	100	T.L.A.	7.0	9.6	1.20	+ 0.020 in.
29	0	Extend	6.8	9.2	1.15	
29	0	Retract	6.8	9.2	1.15	
24	0	Extend	8.0	10.8	1.10	
24	0	Retract	8.0	10.8	1.10	

**RESTRICTED**

**TABLE 4**  
**Testing details for Cub-Jaguar actuators, type 500/1/00640/002**

Applied voltage	Load (lb)	Condition of load	Time in seconds for 2 in. stroke		Maximum current (Amp.)	Stroke tolerance
			(Min.)	(Max.)		
29	100	C.L.O.	14.0	19.2	1.35	
29	100	C.L.A.	13.0	17.8	1.20	- 0.020 in.
29	100	T.L.O.	14.0	19.2	1.35	
29	100	T.L.A.	13.0	17.8	1.20	+ 0.020 in.
29	0	Extend	12.6	17.0	1.15	
29	0	Retract	12.6	17.0	1.15	
24	0	Extend	14.8	20.0	1.10	
24	0	Retract	14.8	20.0	1.10	

**TABLE 5**  
**Testing details for Cub-Jaguar actuator, type 1CZ.82950/1**

Applied voltage	Load (lb)	Condition of load	Time in seconds for 1.08 in. stroke		Maximum current (Amp.)	Stroke tolerance
			(Min.)	(Max.)		
29	100	T.L.O.	7.6	10.4	1.35	+ 0.020 in.
29	100	T.L.A.	7.0	9.6	1.20	
29	100	C.L.O.	7.6	10.4	1.35	- 0.020 in.
29	100	C.L.A.	7.0	9.6	1.20	

**TABLE 6**  
**Testing details for Cub-Jaguar actuator, type 1CZ/136410/2**

Applied voltage	Load (lb)	Condition of load	Time in seconds for 2 in. stroke		Maximum current (Amp.)	Stroke tolerance
			(Min.)	(Max.)		
29	100	T.L.O.	14.0	19.2	1.35	+ 0.020 in.
29	100	T.L.A.	13.0	17.8	1.20	
29	100	C.L.O.	14.0	19.2	1.35	- 0.020 in.
29	100	C.L.A.	13.0	17.8	1.20	

**RESTRICTED**

**TABLE 7****Testing details for Cub-Jaguar actuator, type 1CZ.80360/A**

Applied voltage	Load (lb)	Condition of load	Time in seconds for 2 in. stroke		Maximum current (Amp.)	Stroke tolerance
			(Min.)	(Max.)		
29	100	C.L.O.	9.2	12.0	1.80	
29	100	C.L.A.	8.0	11.20	1.55	- 0.030 in.
29	100	T.L.O.	9.2	12.0	1.80	
29	100	T.L.A.	8.0	11.20	1.55	+ 0.030 in.
18	0	Extend	11.0	14.8	1.35	
18	0	Retract	11.0	14.8	1.35	

**TABLE 8****Testing details for Cub-Jaguar actuators, types 1CZ.80360/B and 1CZ.135840/B**

Applied voltage	Load (lb)	Condition of load	Time in seconds for 2 in. stroke		Maximum current (Amp.)	Stroke tolerance
			(Min.)	(Max.)		
29	100	C.L.O.	3.6	4.7	1.75	
29	100	C.L.A.	3.1	4.1	1.50	- 0.030 in.
29	100	T.L.O.	3.6	4.7	1.75	
29	100	T.L.A.	3.1	4.1	1.50	+ 0.030 in.
18	0	Extend	4.8	6.0	1.2	
18	0	Retract	4.8	6.0	1.2	

**RESTRICTED**

## Appendix 1

## ACTUATOR, PLESSEY, TYPE ICZ 135840/B — VARIANTS

## LEADING PARTICULARS

Actuator, Plessey, Type	Ref. No.
ICZ 135840/B/2	5W/
ICZ 135840/B/3	5W/
ICZ 135840/B/4	5W/3918
ICZ 135840/B/5	5W/3919
ICZ 135840/B/6	5W/
Operating voltage range	18 — 29 d.c.
Working load—Normal	50 lb.
Maximum	75 lb.
Current consumption (normal load)	1.6 amp.
Rating (normal load)	1½ minutes
Ambient temperature range	−50°C to +90°C
Cannon receptacle	CA3102E-14S-5P-F77
Installation details	Ref. No.

ICZ 135840/B	/2	/3	/4	/5	/6
Plunger travel (in.)	2.0	0.5	0.48	1.4	0.625
Retracted centres (in.)	6.6	6.65	6.045	5.794	6.045
Extended centres (in.)	8.6	7.15	6.525	7.194	6.670
Rear end fitting	ICZ 81182	1Z 81801	1Z135485	1Z135485	1Z135485
Front end fitting	Z 60332 (for setting only)	CZ55336 (cushion drive)	1Z135609	1Z135611	1Z135609 (for setting only)

Motor, Plessey, Type C 1305A/3	Ref. No.
Output	0.015 h.p. at 18,000 rev/min
Commutator dia., new	0.490 in.
worn* (min.)	0.495 in.
Undercut micas, depth	0.450 in.
width	0.018 in.
	0.020 in.
	0.018 in.
	0.022 in.
Max. eccentricity	0.0003 in. T.I.R.
Bearing, Type—drive end	Hoffman No. 4666
comm. end	Hoffman No. 463
Brushes, Type	High altitude carbon grade CM5H (Morgan Crucible Co. Ltd.)
Length, new	0.235 in.
worn	0.265 in.
	0.156 in.

\* After skimming to 0.470 in.

RESTRICTED

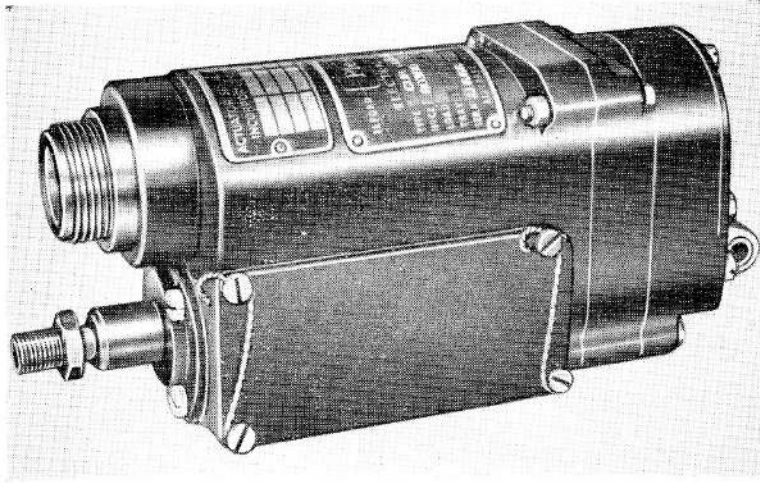

**Fig. 1. General view of actuator, Plessey, Type ICZ135840/B/**

1. The actuators Type ICZ 135840/B/2./3./4./5 and /6 are included in the Cub Jaguar series of linear actuators.

2. A general view of the Type ICZ 135840/B/2 is shown in Fig. 1. The basic construction of these actuators is as described and illustrated in the main chapter, to which reference should be made for further information.

3. These particular variants are fitted with a Cannon receptacle, the internal connections to which are shown in the circuit

diagram in the main chapter. The differences between the variants are in the plunger travel settings (fig. 2) and the end fittings.

4. Rear end fittings of various types are fitted to these actuators and details of these are listed under Leading Particulars. Also listed are the front end fittings, where appropriate.

5. For Installation, and Servicing instructions of these actuators, reference should be made to the main chapter.

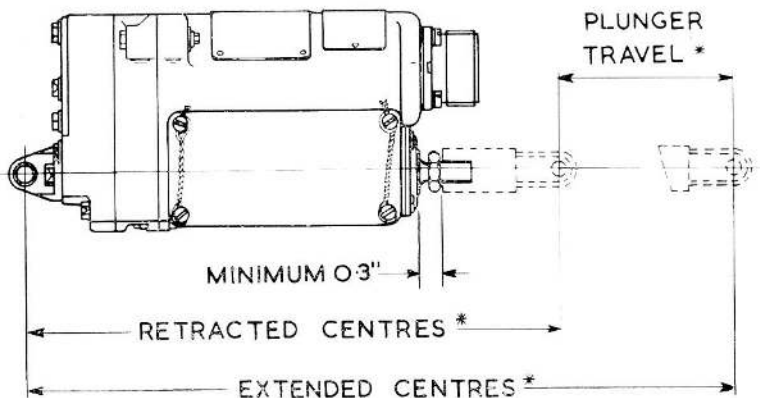

**Fig. 2. Installation details**

**RESTRICTED**



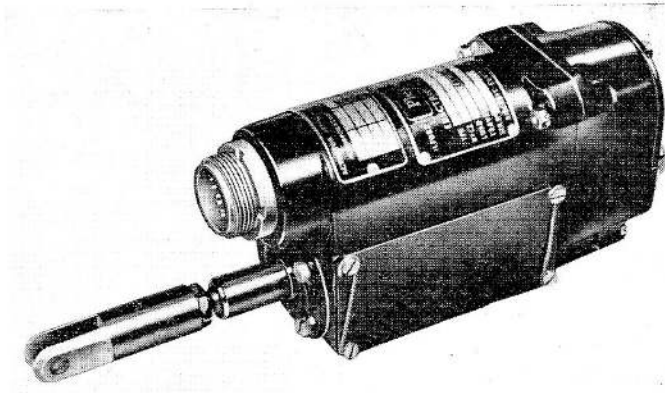

**Fig. 1. General view of actuator**

The basic construction of the actuators, Type 1CZ80360, is as described and illustrated in the main chapter. The gear train is so designed that the gear ratio can be altered from 50 : 1 to 135 : 1. With the gears assembled to the 50 : 1 ratio the actuator becomes Type 1CZ80360/B/-. Electrical connections are made through a 6-pole plug positioned on the front end of the motor housing.

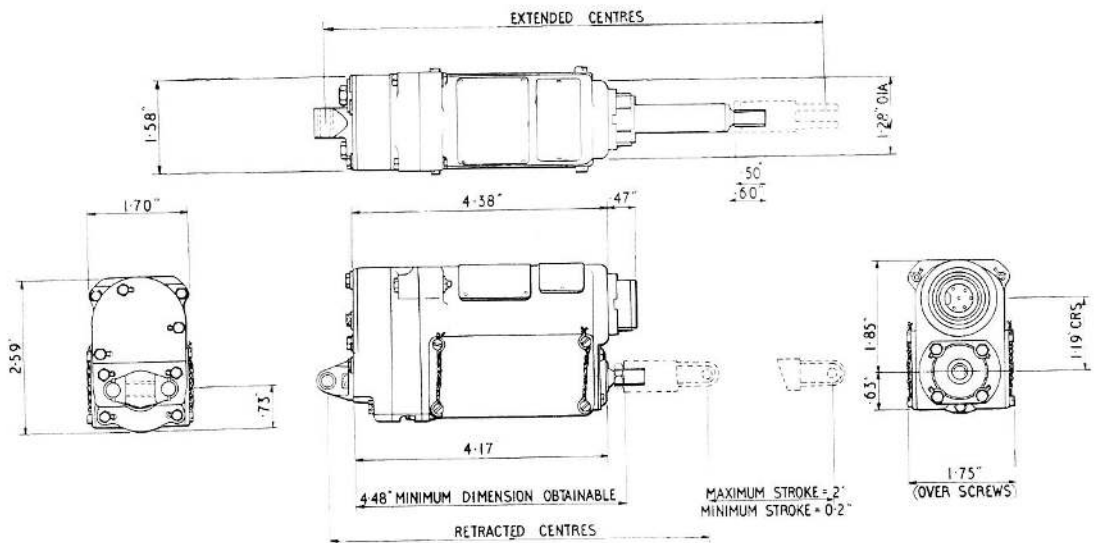

**Fig. 2. Installation details**

**RESTRICTED**

## Appendix 3

**ACTUATORS, PLESSEY, TYPES ICZ 82950/1  
AND  
ICZ 136410/2**

**LEADING PARTICULARS**

<i>Ref. No.</i>	ICZ 82950/1 5W	ICZ 136410/2 5W/3982
<i>Operating voltage range</i>	24-29V d.c.	18-29V d.c.
<i>Working load : normal</i>	100 lb.	100 lb.
<i>                          maximum</i>	150 lb.	150 lb.
<i>Maximum static load</i>	500 lb.	1000 lb.
<i>Plunger travel</i>	1.08 in.	2.00 in.
<i>Operating time :</i>		
<i>  normal load—1.08 in. stroke</i>	7.6 to 10.4 sec.	
<i>  normal load—2.00 in. stroke</i>		14 to 19.2 sec.
<i>Current consumption (normal load)</i>	1.35 amp.	1.35 amp.
<i>Rating (normal load)</i>	1.5 min.	1.5 min.
<i>Ambient temperature range</i>	-65°C to +90°C	-50°C to +90°C

*Motor, Type, Plessey C1305A/3 for both actuators*

*Output* ..... 0.015 h.p. at 18,000 r.p.m.

*Commutator diameter new* ..... 0.490 in.

*worn\** ..... 0.495 in.

*Undercut micas, depth* ..... 0.450 in.

*width* ..... 0.018 in.

*width* ..... 0.020 in.

*width* ..... 0.018 in.

*width* ..... 0.022 in.

*Maximum eccentricity* ..... 0.0003 in. T.I.R.

*Bearings, Type*

*Drive end* ..... Hoffman No. 4666

*Comm. end* ..... Hoffman No. 463

*Brushes, Type* ..... CM5H

*Brush length : new* ..... 0.235 in.

*worn* ..... 0.265 in.

*worn* ..... 0.156 in.

*Brush spring pressure* ..... 3.5 to 4.5 oz.

\* After skimming to 0.470 in.

**RESTRICTED**

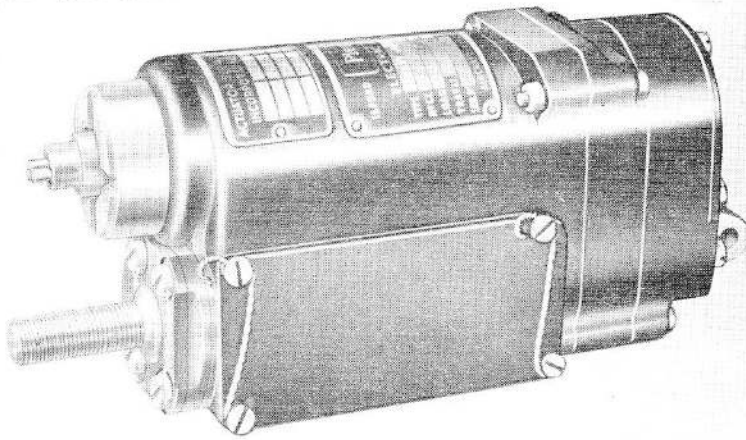

Fig. 1. General view of actuator

**Introduction**

1. The actuators Type ICZ 82950/1 and ICZ 136410/2 are included in the Cub Jaguar series of linear actuators.

**DESCRIPTION**

2. A general view of the actuator is shown in fig. 1, and the Type ICZ 136410/2 is shown sectioned in fig. 2. The basic con-

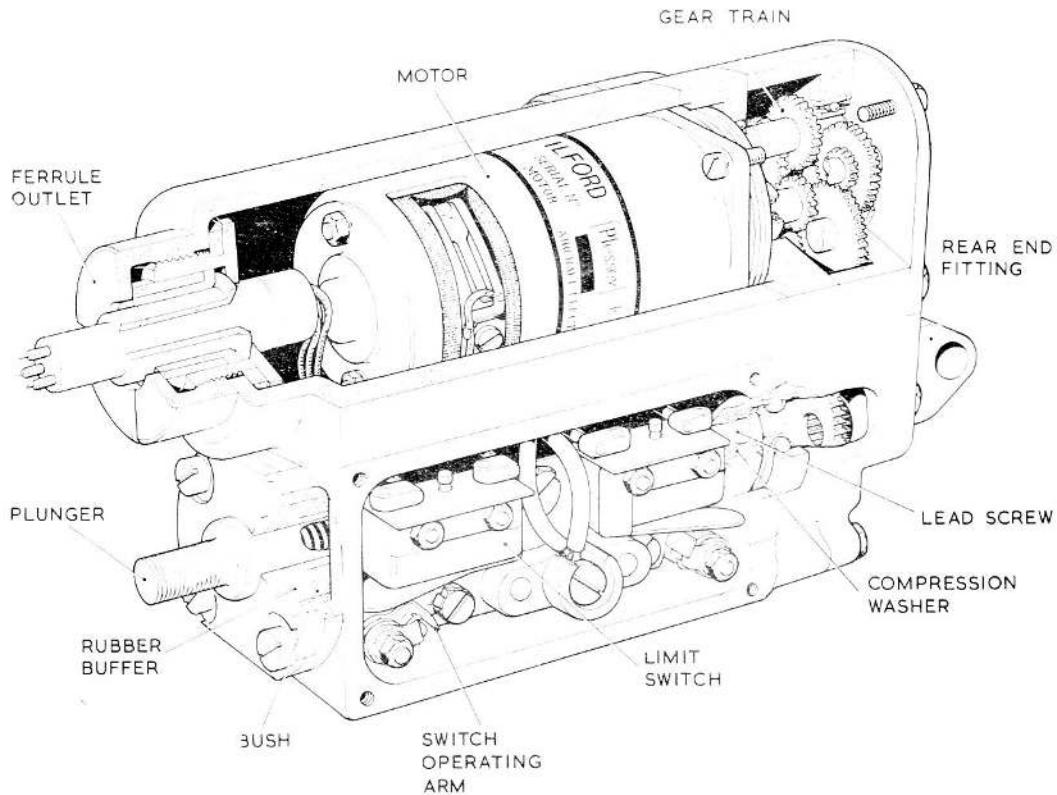
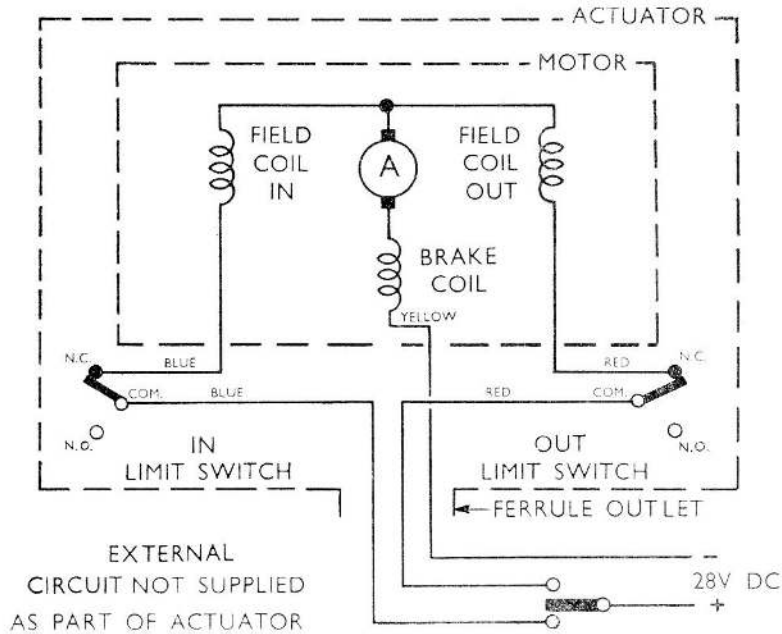

Fig. 2. Sectional view of actuator

**RESTRICTED**



**Fig. 3. Circuit diagram**

struction of these actuators is as described in the main chapter.

3. These particular variants have built-in mechanical stops which, in the event of a switch or wiring fault, prevent the plunger exceeding the set stroke in either direction. Electrical connections to the actuators are made with ferrule outlets and Tripren sheath cables; the internal connections are shown in fig. 3. The differences between the Type ICZ 136410/2 and the ICZ 82950/1 are in the plungers, to facilitate a difference in stroke lengths, and in the end fittings.

#### Mechanical stops

4. In the event of a switch or wiring fault,

movement of the plunger in the retract direction is arrested by the compression washer when the screwed bush at the end of the plunger contacts the stop housing, and in the extend direction by the rubber buffer when the front end of the longer torque reaction ear, contacts the plunger bush.

#### End fittings

5. Eye type rear end fittings are provided, that for the Type ICZ 82950/1 being bushed and having the bore parallel to the actuator vertical centre line: no front end fitting is provided.

**RESTRICTED**

## Appendix 4

### ACTUATORS CUB-JAGUAR PLESSEY, TYPE 1CZ82360 — VARIANTS

#### LEADING PARTICULARS

<i>Basic variants</i> ... ..	1CZ82360/A	1CZ82360/B
<i>Operating voltage range</i> ... ..	18-29V d.c.	18-29V d.c.
<i>Normal voltage</i> ... ..	28V d.c.	28V d.c.
<i>Normal working load</i> ... ..	100 lb.	50 lb.
<i>Maximum working load</i> ... ..	150 lb.	100 lb.
<i>Maximum static load</i> ... ..	500 lb.	500 lb.
<i>Rating at 29V d.c. on normal load</i> ... ..	1½ min.	1½ min.
<i>Ambient temperature range</i> ... ..	-50 to 90 deg. C.	-55 to +99 deg. C.
<i>Weight</i> ... ..	1 lb. 7 oz.	1 lb. 7 oz.
<i>Reduction gear ratio</i> ... ..	135 : 1	50 : 1
<i>Overall dimensions:</i>		
<i>Height</i> ... ..	2.59 in.	
<i>Width (over cover plate screws)</i> ... ..	1.75 in.	
<i>Length (less end fittings)</i> ... ..	4.17 in.	
<i>Motor, Type C1305A/3</i> ... ..	<i>Part No.</i> 4CZ/95868 <i>Ref. No.</i> 5W/3460	
<i>Output</i> ... ..	0.015 h.p. at 18,000 rev/min.	
<i>Commutator dia. new</i> ... ..	0.490 to 0.495 in.	
<i>worn (min.)</i> ... ..	0.450 in.	
<i>after skinning (min.)</i> ... ..	0.470 in.	
<i>Undercut mica inter-segments, depth</i> ... ..	0.018 to 0.020 in.	
<i>width</i> ... ..	0.018 to 0.022 in.	
<i>Maximum eccentricity of commutator to shaft journal</i> ... ..	0.0003 in T.I.R.	
<i>Bearing, drive end</i> ... ..	<i>Hoffman No.</i> 4666 <i>Ref. No.</i> 2A/950183	
<i>commutator end</i> ... ..	<i>Hoffman No.</i> 463 <i>Ref. No.</i> 2A/9501186	
<i>Brushes</i> ... ..	<i>Type</i> H.A.M. E.G. 14 <i>Ref. No.</i> 5W/1041	
<i>Length, new</i> ... ..	0.235 to 0.265 in.	
<i>worn (min.)</i> ... ..	0.156 in.	

**RESTRICTED**

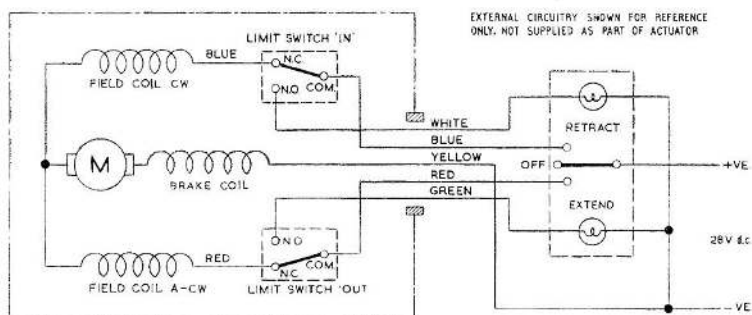

Fig. 1. Circuit diagram

1. Actuators, Plessey Part No. 1CZ82360/A and /B are variants in the Cub-Jaguar series described in the main chapter. These types have a sheathed cable assembly, which extends through the motor housing, for connection to the external electrical circuit; this feature is the main discernible difference between these actuators and other types in the series that employ a plug outlet. The electrical circuit is essentially the same as that shown in the main chapter, the difference being in the colour coding of the leads. The circuit diagram, Fig. 1, includes these changes.

2. Basic variants of this actuator type are identified by /A and /B suffixes to the main part number 1CZ82360. The /A versions have a gear ratio of 135:1 and complete a 2

inch stroke against a normal working load of 100 lb., in 10 seconds; the /B versions have a gear ratio of 50:1 and complete a 2 inch stroke against a normal working load of 50 lb. in 4 seconds. This is effected by employing the normal five-gear train for /A variants, but only three gears for /B variants. /B variants are assembled with the first, second and third gears reversed, as regards their position for /A installation, so that the drive from the motor is transmitted to the third gear, the first and second gears being isolated from the gear drive train.

3. Further variations of the /A and /B versions are identified by suffixed stroke numbers to indicate the differences in stroke setting, centres dimensions etc. as detailed in Table 1.

TABLE 1  
Stroke setting and installation details for 1CZ.82360 actuators

Variant	Ref. No. 5W/	‡Centres (in.)		Stroke (in.)	Front	Rear	Position of Rear End Fitting (Refer to fig. 2) End Fitting
		Retracted	Extended				
/A/1		6.32	8.32	2.0	*Z60332	1Z81801	A
/A/2		5.75	7.75	2.0	Z63856	1Z82955	B
/A/3		5.78	7.78	2.0	Z63856	1Z81179	B
/A/4		5.78	6.155	0.375	Z63856	1Z81179	B
/A/6		6.416	7.602	1.186	Z63582	1Z82955	B
/A/7		6.58	7.92	1.34	CZ55336	CZ81182	A
/A/8		5.78	6.28	0.50	Z63856	1Z81179	B
/A/9	4384	6.337	8.337	2.0	*Z60332	1Z81178	A
/A/10	4709	5.78	6.36	0.58	Z63856	1Z81179	B
/B/1		6.32	8.32	2.0	*Z60332	1Z81801	A
/B/2	2802	6.32	7.81	1.49	*Z60332	1Z81801	A
/B/3		5.34	7.34	2.0	Z63856	†1Z136362	—
/B/4		6.33	8.33	2.0	*Z60332	1Z81178	A

RESTRICTED

‡ The centres dimension must be within the limits

Retracted +0.000  
-0.010

Extended +0.010  
-0.000

\* Z60332 used for stroke setting only; not supplied with actuator.

† To set the stroke of the variant 1CZ82360/B/3, the rear end fitting 1Z136362 must be removed and replaced temporarily with a rear end fitting 1Z81801. This will increase the centres dimensions by 0.42 in. i.e. the retracted centres dimensions becomes 5.76 in.; the extended centres dimension becomes 7.76 in. After stroke setting to these dimensions the rear end fitting 1Z81801 must be removed and replaced with the original rear end fitting 1Z136362.

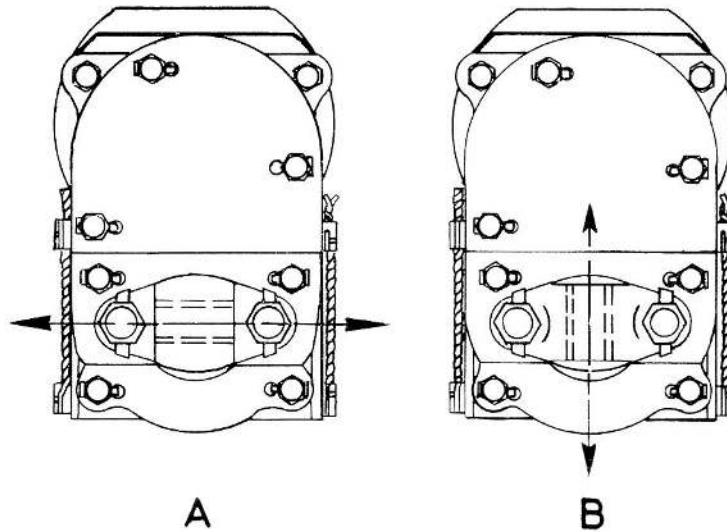

Fig. 2. Alternative positions of rear end fitting

## Appendix 5

ACTUATORS, CUB-JAGUAR, PLESSEY  
TYPE 500/1/00640 — VARIANTS

## LEADING PARTICULARS

Actuator, Part No. 500/1/00640/001	...	...	...	...	Ref. No. 5W/4484
Actuator, Part No. 500/1/00640/002	...	...	...	...	Ref. No. 5W/4485
Voltage range	...	...	...	...	24 to 29V d.c.
Normal voltage	...	...	...	...	28V d.c.
Normal working load	...	...	...	...	100 lb.
Maximum working load	...	...	...	...	150 lb.
Maximum static load	...	...	...	...	500 lb.
Rating at normal load	...	...	...	...	1½ min.
Maximum operating frequency	...	...	...	...	50 inching cycles/hr.
Ambient temperature range	...	...	...	...	-65 to +90 deg. C.
Weight	...	...	...	...	1 lb. 11 oz.
Reduction gear ratio	...	...	...	...	263:1
Overall dimensions:					
Height	...	...	...	...	2.59 in.
Width (over screws)	...	...	...	...	1.75 in.
Length (rear end fitting to front of cable outlet)	...	...	...	...	5.15 in.
Motor, Type C1305A/8	...	...	...	...	Part No. 4CZ95865
Output	...	...	...	0.015 h.p.	at 18,000 rev/min.
Commutator dia., new	...	...	...	...	0.490 to 0.495 in.
worn (min.)	...	...	...	...	0.450 in.
after skimming (min.)	...	...	...	...	0.470 in.
Undercut mica inter-segments, depth	...	...	...	...	0.018 to 0.020 in.
width	...	...	...	...	0.018 to 0.022 in.
Maximum eccentricity of commutator to shaft journal	...	...	...	...	0.0003 in. T.I.R.
Bearing, drive end	...	...	...	...	Hoffman 4666
commutator end	...	...	...	...	Ref. No. 2A/9501383
Brushes	...	...	...	...	Hoffman N463
Length, New	...	...	...	...	Ref. No. 2A/9501186
worn (min.)	...	...	...	...	Type H.A.M. E.G.14
	...	...	...	...	Ref. No. 5W/1041
	...	...	...	...	0.235 to 0.265 in.
	...	...	...	...	0.156 in.

RESTRICTED

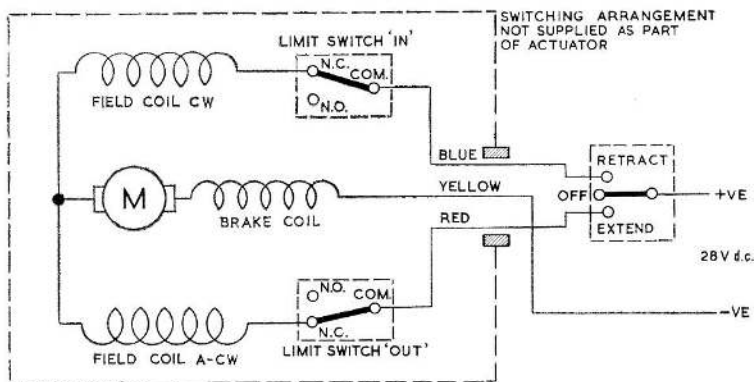

**Fig. 1. Circuit diagram**

1. These actuators, Plessey Part No. 500/1/00640/001 and /002 are variants in the Cub-Jaguar series described in the main chapter. A new design feature in these actuators is the incorporation of mechanical stops to arrest the movement of the plunger and confine its travel to within the plunger housing in the event of failure of the normal stroke control arrangement. This feature consists basically of a cushioned fitting, suitably attached to each end of the plunger housing, against which the plunger will butt when its travel is uncontrolled. An additional feature is a mid-stroke position marking on the body of the plunger to facilitate installation. The variants 500/1/00640/001 and /002 are identical except for the rear end fitting and the plunger which varies to suit the different stroke setting positions.

2. The actuator is fitted with the later version of the switch operating mechanism described and illustrated in the main chapter

and the full five-gear transmission is used in the reduction gear drive train. A three-wire sheathed cable assembly that extends through the front housing is provided for connection to the external circuit; the actuator is not wired for connection to external indicators. A schematic diagram of the electrical circuit is shown in Fig. 1.

3. Reference must be made to the main chapter for a general description of these actuators. The operation is described in the main chapter with the additional feature that, should there be mechanical or electrical malfunctioning of the stroke controlling arrangement, travel of the plunger will be arrested when the plunger butts against the appropriate mechanical stop fitted in the housing.

4. The general installation instructions in the main chapter also apply to this actuator; details of the variants are given in Table 1. The details tabulated are the only differences between the variants.

**TABLE 1**  
**Stroke setting and installation details for 500/1/00640 actuators**

Variant	Ref. No. 5W/	Centres (nominal)		Stroke (in.)	Rear End Fitting Position (Refer Part No. to fig. 2)	
		Retracted (in.)	Extended (in.)			
/001	4484	5.870	6.950	1.08	+0.000 -0.010	1CZ82954 A
/002	4485	5.900	7.9	2.00	+0.000 -0.010	500/2/000 B

**RESTRICTED**

**Note . . .**

*Front end fittings are not supplied with the actuators, hence the tabulated centres dimensions, which are those obtained when stroke setting on the rig with a special eye end, may be varied according to the particular actuator installation.*

5. The servicing instructions in the main chapter apply to this type, in addition, a Standard Serviceability Test on these actuators is contained in Appendix A.

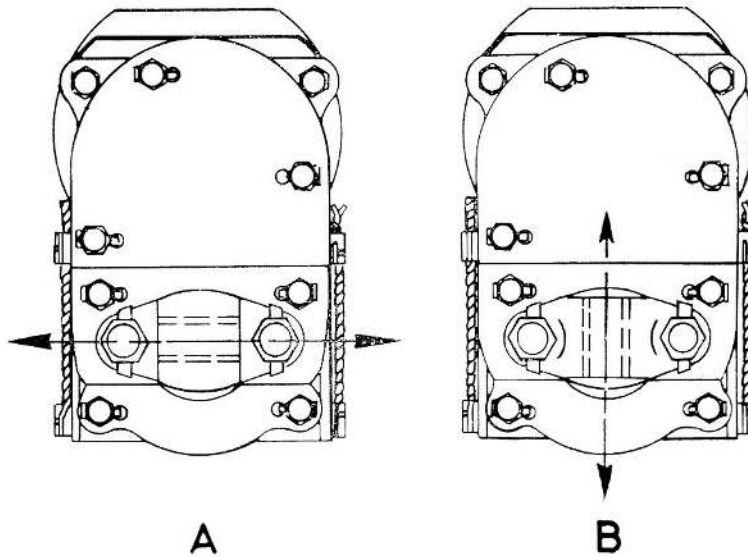

Fig. 2. Alternative positions of rear end fitting

**RESTRICTED**

## Appendix 6

ACTUATOR, CUB-JAGUAR, PLESSEY, TYPE 500/1/00370  
—VARIANTS

## LIST OF ILLUSTRATIONS

Switch operating mechanism ... ..	Fig. 1
Alternative position of rear end fitting	2

## LEADING PARTICULARS

Basic variants ... ..	500/1/00370/001 and /002
Gearbox ... ..	Type A
Reduction gear ratio ... ..	135:1
Normal working load ... ..	100 lb.
Maximum working load ... ..	150 lb.
Voltage range ... ..	18-29V d.c.
Normal voltage ... ..	28V d.c.
Maximum static load ... ..	500 lb.
Rating at normal load ... ..	1½ min.
Maximum operating frequency ... ..	50 inching cycles/hr.
Ambient temperature range ... ..	-50 to +150 deg. C.
Weight ... ..	1 lb. 8 oz.
Overall dimensions: height ... ..	2.73 in.
width (over screws) ... ..	1.75 in.
length (rear of body to front of plug) ... ..	5.59 in.
Motor, Type C1305A/5 ... ..	Plessey Part No. 4CZ94470
Output ... ..	0.015 h.p. at 18,000 rev/min
Commutator dia., new ... ..	0.490 to 0.495 in.
after skimming (min.) ... ..	0.470 in.
worn (min.) ... ..	0.450 in.
Undercut mica inter-segments, depth ... ..	0.018 to 0.020 in.
width ... ..	0.018 to 0.020 in.
Maximum eccentricity of commutator to shaft journal ... ..	0.0003 in. T.I.R.
Bearing, drive end ... ..	Hoffman 4666, Ref. No. 2A/9501383
commutator end ... ..	Hoffman N463 Ref. No. 2A/9501186
Brushes	
Grade ... ..	Type HAM, EG.14 Ref. No. 5W/1041
New length ... ..	0.235 to 0.265 in.
Minimum length (min.) ... ..	0.156 in.

RESTRICTED

1. These actuators, Plessey Type 500/1/00370, are variants in the Cub-Jaguar series, described in the main chapter, but are designed to operate under higher temperatures than the normal Cub-Jaguar range. This type is fitted with the later version of the switch operating mechanism which is described and illustrated in the main chapter. A 5-pin plug provides the connection to the external electrical circuit. As the 5-pin plug has a large flange, the mounting holes in the actuator body have been repositioned so that when mounted, the edges of the plug flange do not extend from the sides of the actuator. The circuit diagram for this type of actuator is the same as the typical circuit shown in the main chapter.

2. The type variants are identified by stroke numbers suffixed to the main part number 500/1/00370 to denote differences in the stroke and the centres positions. The short stroke of the 002 variant, necessitates a modified switch operating mechanism which is illustrated in fig. 1 of this appendix. Stroke setting, installation and gearbox

details for the variants of this type of actuator are given in Table 1 of this appendix. For general instructions on installation, reference should be made to the main chapter.

### Brushgear

3. Access to the brushgear necessitates partial dismantling of the actuator, as detailed in the main chapter. At the periods prescribed in the relevant Servicing Schedule, the actuator should be dismantled to examine the brushgear, bearings, etc., Servicing instructions, together with relevant illustrations are contained in the main chapter.

### Functional tests

4. The linear actuator test rig is described and illustrated in A.P.4343S, Vol. 1, Book 2, Sect. 8. Set the actuator to be tested on the test rig and adjust the stroke to  $2.0 \pm 0.03$  in. on no-load with the supply set to 25 volts. Check that when the actuator is operated

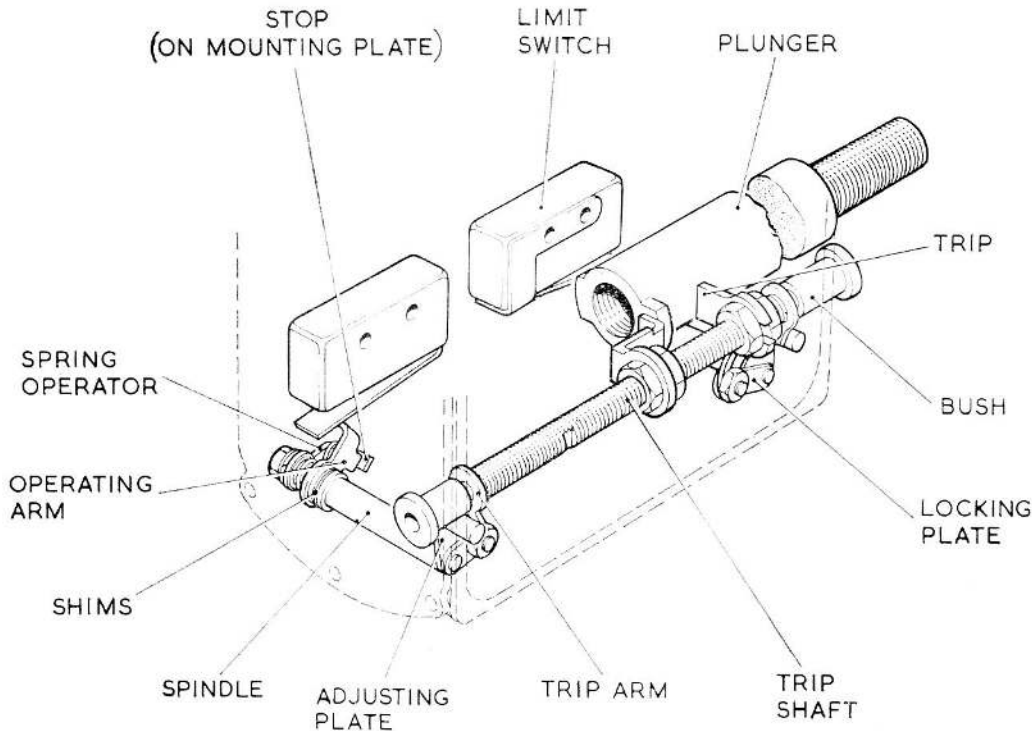
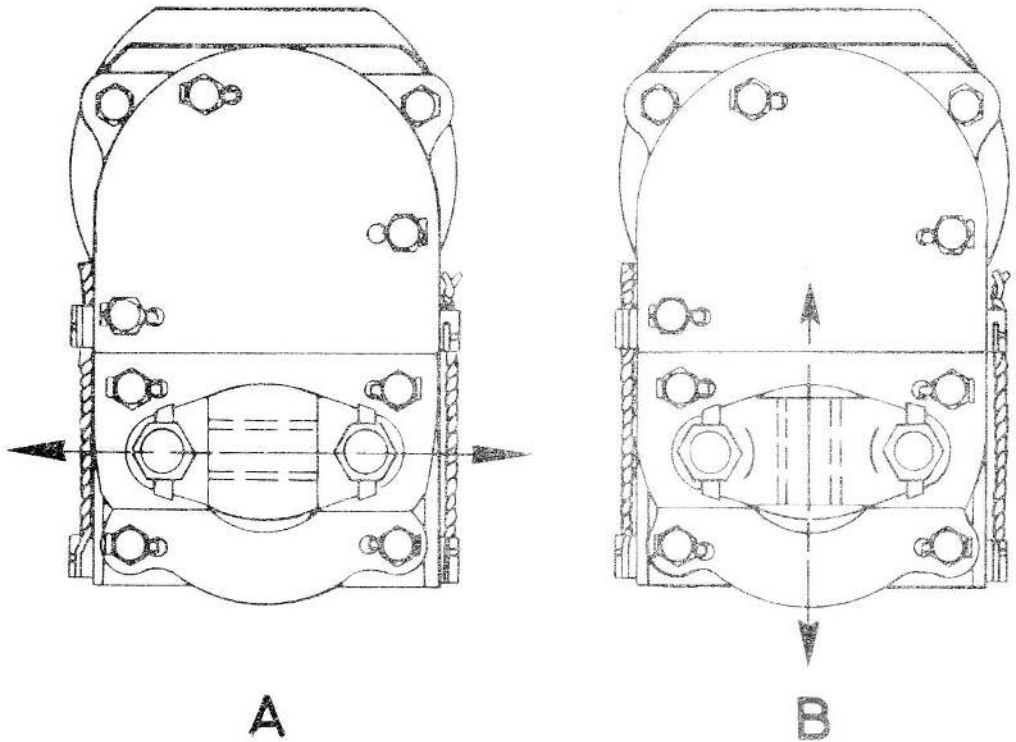

Fig. 1. Switch operating mechanism

RESTRICTED



**A**  
**B**  
Fig. 2. Alternative position of rear end fitting

through its full stroke under the full and no-load conditions detailed in Appendix A, Table 9, the tabulated limits are not exceeded.

5. Adjust the centres dimensions and stroke against a 6 lb. load with the supply set to 25 volts, as detailed in Table 1. The extended centres dimension should be set first. The retracted centres dimension is then set to give the correct stroke. Check that when the

actuator is operated through its full stroke, the tabulated limits are not exceeded.

6. Check that the limit switches function correctly by noting the behaviour of the indicators.

7. Check that no excessive vibration can be detected when the actuator is being operated.

8. Perform several inching strokes in each direction to check for satisfactory operation.

**TABLE 1**  
**Stroke setting, installation and gearbox details for 500/1/00370 actuators**

Variant	Centres		Stroke (in.)	End fitting		Gearbox Type	Position of rear end fitting (refer to fig. 2)
	Extend (in.)	Retract (in.)		Front	Rear		
/001	7.80+0.010 -0.000	6.80+0.000 -0.010	1.00	Z60322	1Z81801	A	A
/002	7.90+0.010 -0.000	7.70+0.000 -0.010	0.2	Z60322	1Z81801	A	A

**RESTRICTED**

## Appendix 7

ACTUATOR, CUB-JAGUAR, PLESSEY, TYPE 500/1/01320  
—VARIANTS

## LIST OF ILLUSTRATIONS

	Fig.		Fig.
Sectioned view of actuator ... ..	1	Circuit diagram ... ..	3
Switch operating details ... ..	2	Installation diagram ... ..	4

## LEADING PARTICULARS

Basic variant ... ..	500/1/01320/001
Operating voltage ... ..	18-29V d.c.
Normal voltage ... ..	28V d.c.
Normal working load ... ..	100 lb.
Maximum working load ... ..	150 lb.
Maximum static load ... ..	500 lb.
Rating at 29V d.c. on normal load ... ..	1½ min.
Ambient temperature range ... ..	-50 to +90 deg. C.
Weight ... ..	1.44 lb.
Reduction gear ratio ... ..	135:1
Overall dimensions, including cranked plug adaptor assembly:	
height ... ..	2.90 in.
width ... ..	3.45 in.
length (less end fitting) ... ..	5.46 in.
Motor, Type C1305A/8 ... ..	Plessey Part No. 4CZ95868
Output ... ..	0.015 h.p. at 18,000 rev/min
Commutator dia., new ... ..	0.490 to 0.495 in.
after skimming (min.) ... ..	0.470 in.
worn (min.) ... ..	0.450 in.
Undercut mica intersegments, depth ... ..	0.018 to 0.020 in.
width ... ..	0.018 to 0.222 in.
Maximum eccentricity of commutator to shaft journal ... ..	0.0003 in., T.I.R.
Bearing, drive end ... ..	Hoffman 4666. Ref. No. 2A/9501383
commutator end ... ..	Hoffman N463. Ref. No. 2A/9501186
Brushes	
Grade ... ..	Type H.A.M. EG.14. Ref. No. 5W/1041
New length ... ..	0.235 to 0.265 in.
Minimum length ... ..	0.156 in.
Spring pressure ... ..	3½ to 4½ oz.

RESTRICTED

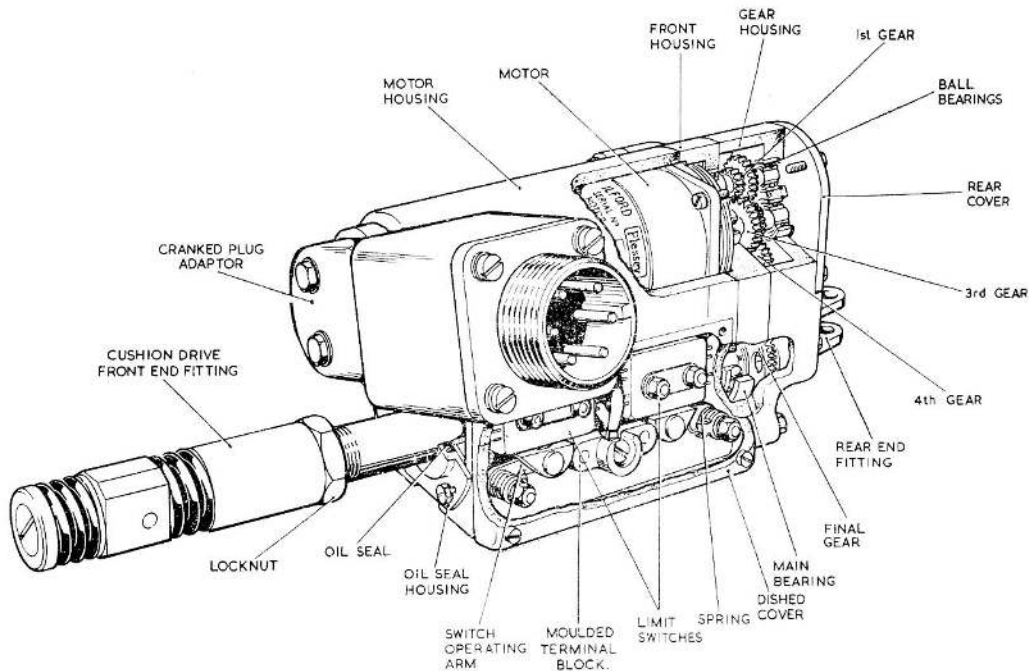

**Fig. 1. Sectional view of actuator**

1. These actuators, Plessey Type 500/1/01320 are variants in the Cub-Jaguar series described in the main chapter. This type has a cranked plug adaptor assembly, a dished switch cover assembly and a cushion drive front end fitting. These are the main discernible differences in external appearances between these actuators and other types in the series. Other changes include double-pole limit switches, modified switch mountings and switch operating mechanisms. The plunger assembly has been changed to suit the cushion drive front end fitting. These changes are shown in the sectioned view, fig. 1 and the switch operating details, fig. 2. The circuit diagram is shown in fig. 3 and the installation diagram in fig. 4.

### **Dismantling**

2. The method of gaining access to the brushes differs from that described in the main chapter; the procedure in this instance is as follows:—

(1) Remove the cushion drive and locknut from the plunger.

(2) Remove the side cover and the dished switch cover (four screws each).

(3) Remove the screw in the moulded terminal block between the two switches to free the yellow-sleeved leads.

(4) Release the tabs on the locking plates and remove the four nuts securing the switches to the switch mounting plate. Discard the locking plates.

(5) Withdraw the switches sufficiently to gain access to the switch terminals and unsolder the red and blue motor leads.

(6) Turn the actuator over and free the two nuts holding the trip nearest the gearbox. Run the inner nut towards the centre and lift the trip out of the slot in the housing, there is a dimple in the threaded rod to permit this.

(7) Remove the four bolts surrounding the rear end fitting and the special nut and bolt underneath.

**RESTRICTED**

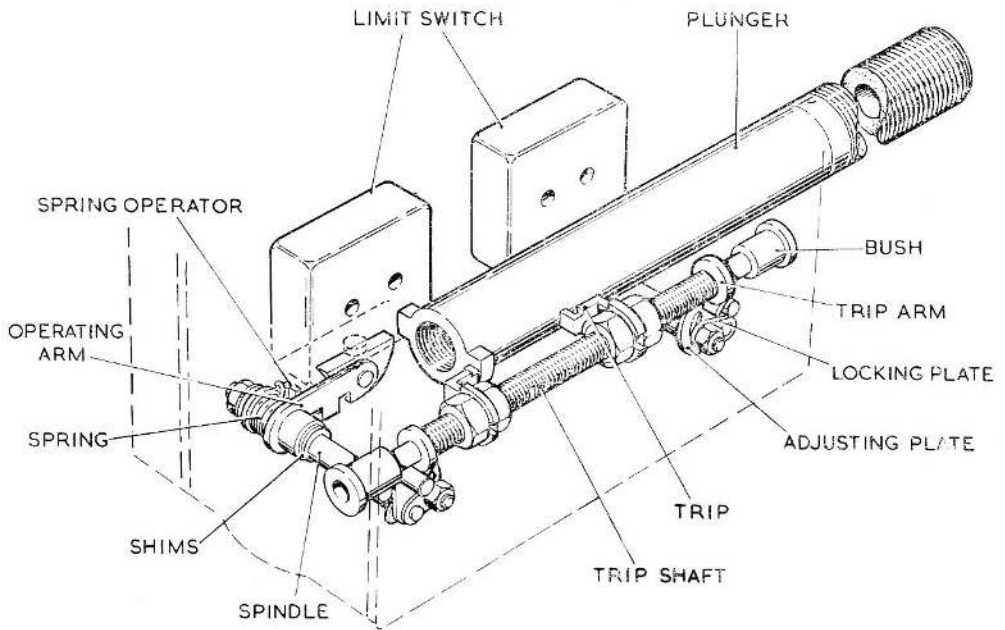

Fig. 2. Switch operating mechanism

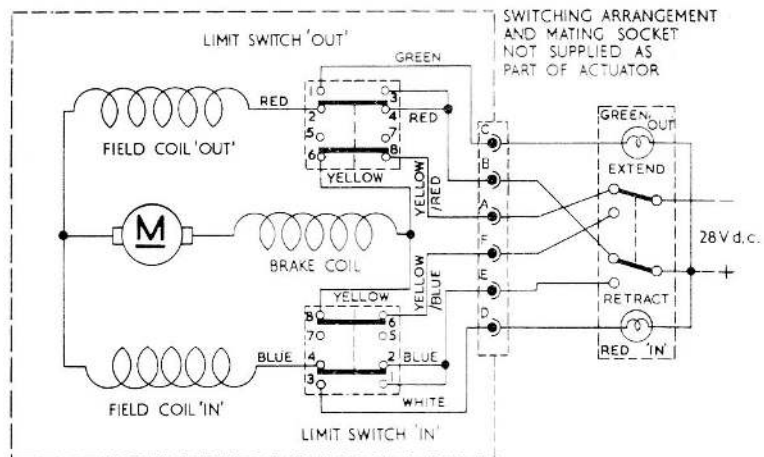
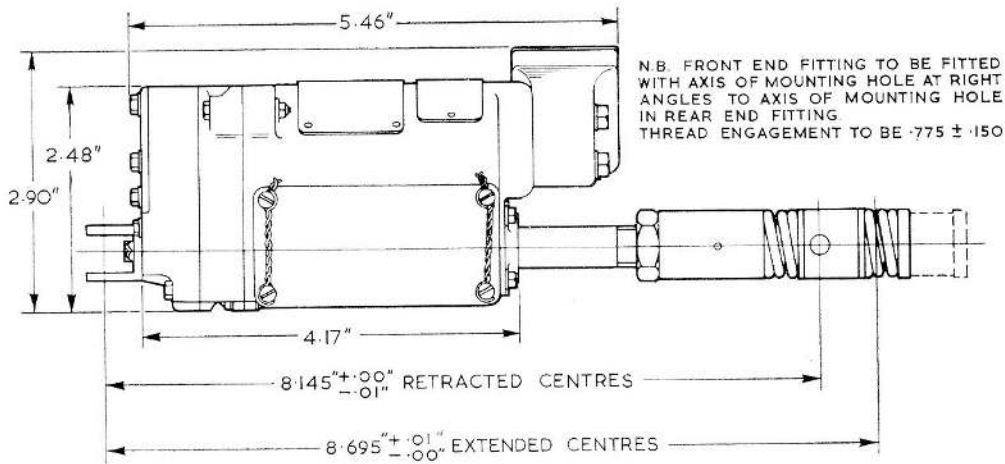

Fig. 3. Circuit diagram

(8) Using two spanners, slacken as far as possible the two bolts which pass through the web nearest the labels. Separate the actuator at the joint be-

tween the front housing and the gearbox and carefully ease apart. Continue to separate, unscrewing the two nuts until they fall clear.

**RESTRICTED**



**Fig. 4. Installation diagram**

(9) Withdraw the gearbox, complete with motor and plunger, from the front cover.

### Brushgear

3. Examine the brushgear; fit new brushes as necessary, as described in the main chapter.

4. To remove the motor for brush bedding, the four screws securing the motor to the motor housing must be removed; the motor may then be withdrawn. Information on brush bedding is contained in the main chapter, and further details in A.P.4343, Vol. 1, Sect. 1, Chap. 2.

### Re-assembly

5. Re-assembly is performed generally in the reverse order to dismantling. All tab washers and the locking plates securing the switch nuts must be replaced by new. Gaskets must be renewed and all jointing surfaces must be coated with HYLOMAR SQ32R sealing compound. The trip should be locked with its nuts in its approximate original position. After the actuator has been completely re-assembled, the edges of all joints must be painted with Cellon epoxy

lacquer (mixture SL5459 and CSL5538) to effect the Skydrol sealing.

### Note . . .

*The removal of the trip invalidates the stroke setting of this type of actuator. Instructions for resetting the stroke after re-assembly will be issued later.*

### Functional test

6. The linear actuator test rig is described and illustrated in A.P.4343S, Vol. 1, Book 2, Sect. 8. The special front end fitting Plessey Part No. SK16337 is required when checking the stroke, with this type of actuator; the extension rod Plessey Part No. T381560/2 is necessary to prevent the plug assembly on the actuator fouling the test rig. The external switching and indicating circuit is shown in fig. 3.

7. Remove the cushion drive assembly and fit the special front end fitting, Plessey Part No. SK16337. Set the actuator on the test rig, using the extension rod between the front end fitting and the test rig mounting. Adjust the stroke to  $2.0 \pm 0.03$  in. on no-load with the supply set to 25 volts. Check that when the actuator is operated through its full stroke under the full and no-load conditions detailed in Table 1, the tabulated limits are not exceeded.

**RESTRICTED**

8. Variations of the 500/1/01320 actuators are identified by suffixed stroke numbers to indicate the differences in stroke setting, centres dimensions, etc., as detailed in Table 1.

9. Remove the special front end fitting and refit the cushion drive assembly in its original position on the plunger. Adjust the centres dimensions and stroke against a 6 lb. load with the supply set to 25 volts as detailed in Table 1 of Appendix A.

10. Check that the limit switches function correctly, by noting the behaviour of the indicator lamps.

11. Check that no excessive vibration is felt when the actuator is being operated. Perform several inching strokes in each direction to

check for satisfactory operation of the brake.

12. Operate the actuator to bring the plunger to its mid position. Apply a compressive load of 6 lb. and note the centres dimension. Increase the load to 45 lb. compressive and again note the centres dimension. The difference between the two centres dimension must not exceed 0.012 in. Increase the compressive load to 100 lb. The total change in centres dimension from 6 lb. to 100 lb. loading must not exceed 0.030 in.

13. Repeat the previous checks with a tensile loading of 6 lb., 45 lb. and 100 lb. The changes in centres dimension must not exceed the limits given for compressive loading.

**TABLE 1**

Variant	Centres		Stroke (in.)	End fittings		(Special front)
	Retracted (in.)	Extended (in.)		Front	Rear	
/001	8.145 ± 0.00 -0.01	8.695 ± 0.01 -0.00	0.55 ± 0.01	500/1/01344	1Z81215/8	SK16337

**RESTRICTED**

This file was downloaded from the RTFM Library.  
Link: [www.scottbouch.com/rtfm](http://www.scottbouch.com/rtfm)

Please see site for usage terms, and more aircraft documents.

