

## Chapter 71

## ACTUATOR, WESTERN, TYPE EJ50, Mk. 30

## LIST OF CONTENTS

	Para.		Para.
<i>Introduction</i> .....	1	<i>Limit switches</i> .....	7
<b>Description</b> .....	2	<i>Electrical connections</i> .....	8
<i>Motor and reduction gearing</i> .....	3	<i>Applicating and loading</i> .....	9
<i>Electro-magnetic brake</i> .....	4	<b>Installation and Servicing</b> .....	10
<i>End fittings</i> .....	6	<i>Insulation resistance test</i> .....	13

## LIST OF ILLUSTRATIONS

	Fig.
<i>Sectional view of actuator</i> .....	1
<i>Circuit diagram</i> .....	2
<i>Installation drawing</i> .....	3

## LEADING PARTICULARS

<b>Actuator, Western, Type EJ50, Mk.30</b> .....	<i>Ref. No. 5W/405</i>
<i>Voltage range</i> .....	22 to 29 volt d.c.
<i>Normal voltage</i> .....	24 volt d.c.
<i>Normal working load</i> .....	50 lb.
<i>Current at normal working load</i> .....	1.4 amp.
<i>Maximum working load</i> .....	100 lb.
<i>Stalling load</i> .....	160 lb.
<i>Stall current</i> .....	2.7 amp.
<i>Length of stroke</i> .....	2 in.
<i>Time of stroke at normal load</i> .....	15 sec.
<i>Fixing centres</i>	
<i>Extended</i> .....	10.812 in.
<i>Retracted</i> .....	8.812 in.
<i>Time Rating</i> .....	1 minute
<i>Rating of motor</i> .....	0.008 h.p., at 5800 r.p.m.
<i>Brush spring pressure</i> .....	1.5 to 2 oz.
<i>Minimum length of brushes</i> .....	0.06 in.
<i>Resistance of field coils (together)</i> .....	3 ohms.
<i>Ambient temperature range</i> .....	-55 deg.C. to +90 deg.C.
<i>Maximum altitude</i> .....	60,000 ft.
<i>Type of screw jack</i> .....	$\frac{5}{16}$ in. single start, R.H. Acme, 16 T.P.I.
<i>Weight</i> .....	1 lb. 14 oz.

## Introduction

1. The actuator, Western, Type EJ50, Mk. 30 is a linear, in-line actuator and is designed to operate for 1 minute at a nominal load of 50 lb. with a current consumption not exceeding 1.5 amperes.

## DESCRIPTION

2. A general description of Western Type EJ series of actuators is described in A.P.4343, Vol. 1, Sect. 17, Chap. 2 and App. 7. They differ from others in the series in respect of fixing centres, type of end fittings, gearbox reduction ratio, operating times, current consumption and loads. Additional information peculiar to this actuator is contained in this chapter.

## Motor and reduction gearing

3. The motor is a split series type, whose field coils also control the operation of the brake. The drive from the motor is transmitted through a 3-stage epicyclic gear train, with a reduction ratio of 118 : 1.

## Electro-magnetic brake

4. The brake (fig. 1) comprises a spring loaded brake plate with a friction lining on one face. The lined face is adjacent to the face of the brake disc, which is integral with the motor armature shaft. The brake plate can move only longitudinally, and the brake disc rotates with the motor.

5. Operation of the brake is controlled by the motor field coils, so that when the coils are energized the brake is held off the brake disc. With the motor de-energised the brake plate contacts the brake disc and prevents over-run.

## Note . . .

*No brake coil is fitted in this actuator (fig. 2).*

## End Fittings

6. A single start,  $\frac{7}{16}$  in. screw jack operating worm, driven by the motor through reduction gearing, extends and retracts a piston at the moving end of the actuator. This piston has a self-aligning, spherical bearing which forms an eye for connecting the actuator to the equipment it operates. The fitting at the motor end is a fixed mounting provided with a link which allows for mis-alignment up to 6 degrees.

## Limit Switches

7. Linear travel of the piston is controlled

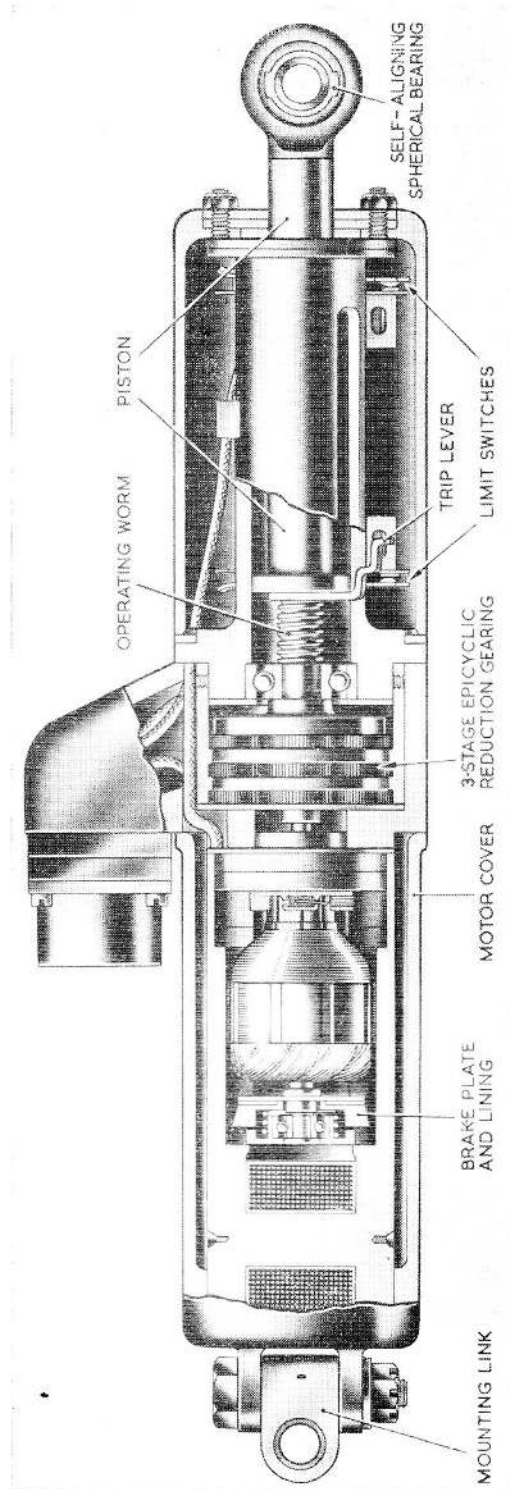

Fig. 1. Sectional View of Actuator.

RESTRICTED

by two snap-action, make-and-break limit switches, operated by a trip lever attached to the inner end of the piston. Switching of the actuator takes place at the fully extended and fully retracted positions of the piston.

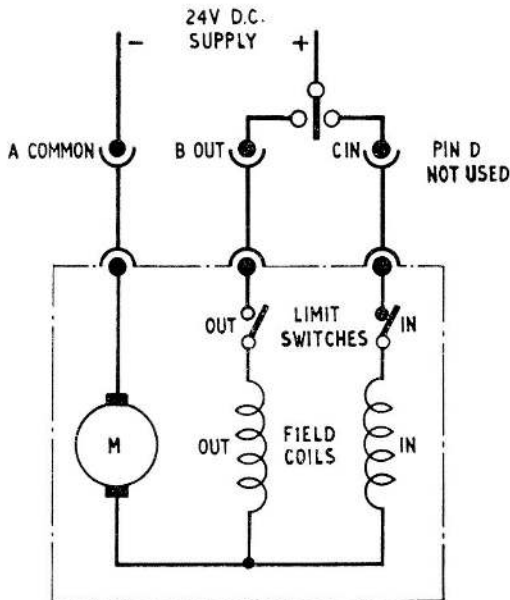

Fig. 2. Circuit Diagram.

### Electrical connections

8. The internal wiring (fig. 2) of the actuator is brought out to a 4-pole Breeze plug, which is mounted on an elbow of the gear casing. Pin D of the 4-pole Breeze plug is not used.

### Application and loading

9. Two snap-action limit switches are adjusted during assembly to provide a 2.0 inch stroke of the piston. A functional test should be performed by connecting the actuator to a 28 volt d.c. supply and applying loads of 0, 50 and 100 lb. The time the piston takes to complete its 2.0 inch stroke, and the current consumption at these loads must not exceed the values given in the following table.

Load (lb)	Max. time (sec.)	Max. current (amp.)
0	14 ± 3	1.10
50	15 ± 3	1.40
100	16 ± 3	1.90

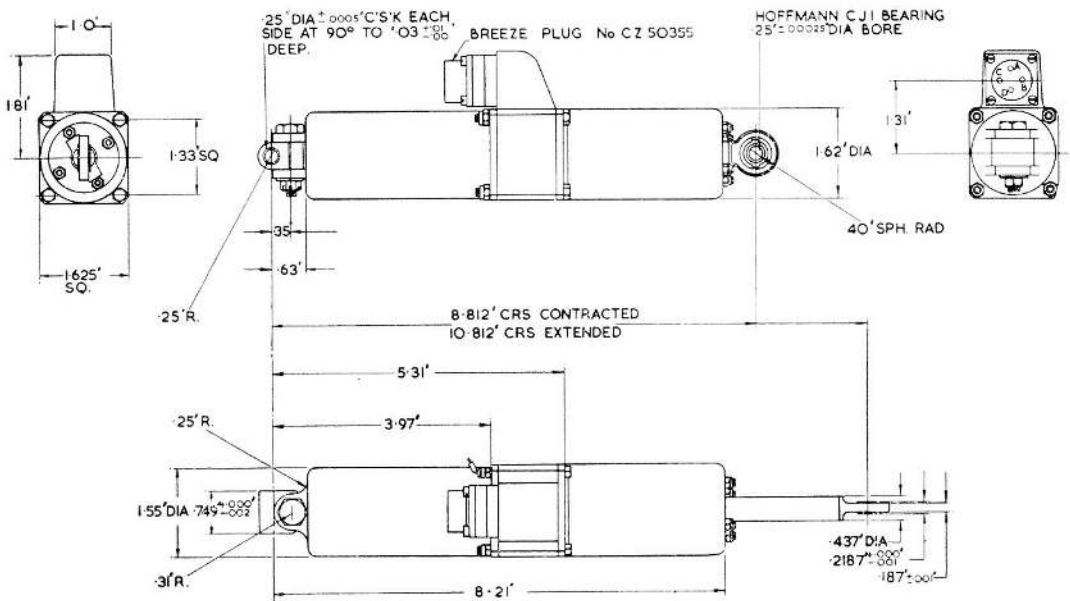

Fig. 3. Installation Drawing.

## INSTALLATION AND SERVICING

**10.** Installation and servicing instructions other than given in this chapter are contained in A.P.4343, Vol. 1, Sect. 17, Chap. 2 and App. 7, and the relevant Aircraft Handbook.

**11.** Access to the brake, motor and brush-gear is obtained by removing the motor cover. This is accomplished by removing the four nuts securing the cover to the gear casing and drawing the cover from the gear casing.

### **Note . . .**

*Care should be exercised when removing the cover, as the pole pieces and yoke are located*

*in a bore in the bottom of the cover, allowing the motor to sag.*

**12.** On completion of the servicing, refit the cover and lock the securing screws with 24 S.W.G., cadmium plated, soft iron wire.

### **Insulation resistance test**

**13.** Using a 250 volt insulation resistance tester, test between plug pins and earth. The measured insulation resistance must not be less than 2 megohms.

**14.** Due to the humid conditions prevalent in aircraft when in service, the permissible insulation resistance may be reduced to not less than 50,000 ohms.

**RESTRICTED**

This file was downloaded  
from the RTFM Library.

Link: [www.scottbouch.com/rtfm](http://www.scottbouch.com/rtfm)

Please see site for usage terms,  
and more aircraft documents.

