

Chapter 74

ACTUATOR, ENGLISH ELECTRIC, TYPE AE 4021, Mk. 1

LIST OF CONTENTS

	<i>Para.</i>		<i>Para.</i>
<i>Introduction</i>	1	Operation	47
Description		Servicing	
<i>General</i>	2	<i>General</i>	53
<i>Housing and covers</i>	5	<i>Brushgear</i>	54
<i>Motor and brake assembly</i>	11	<i>Potentiometer</i>	57
<i>Gearbox</i>	18	<i>Lubrication</i>	59
<i>Drive shafts and ball nut mechanism</i>	25	<i>Eye end safety</i>	60
<i>Limit switches</i>	33	<i>Final inspection</i>	64
<i>Potentiometer</i>	34	<i>Insulation resistance test</i>	65
Installation	37		

LIST OF ILLUSTRATIONS

	<i>Fig.</i>		<i>Fig.</i>
<i>General view of actuator</i>	1	<i>Practical wiring diagram</i>	4
<i>Sectional view of actuator</i>	2	<i>Performance curves of tensile and com-</i>	
<i>Sectional view of motor</i>	3	<i>prehensive loading</i>	5

LEADING PARTICULARS

<i>Actuator, English Electric Type AE 4021, Mk. 1</i>	<i>Ref. No. 5W/2076</i>
<i>Voltage</i>	28 volt d.c.
<i>Speed of motor</i>	11,000 r.p.m.
<i>Input to motor</i>	550 watts
<i>Maximum working load (tension)</i>	14,800 lb.
<i>Maximum working load (compression)</i>	11,200 lb.
<i>Clutch slip load</i>	15,000 to 16,000 lb.
<i>Stroke between stops</i>	1.760 to 1.780 in.
<i>Time taken for normal working stroke</i>	4.75 seconds
<i>Distance between centres</i>	Refer to para. 38
<i>Minimum brush length</i>	0.5 in.
<i>Brush spring pressure</i>	15 to 21 ounces
<i>Brush grade</i>	E.G.O. (HAM)

Introduction

1. The linear actuator, Type AE 4021, Mk. 1 provides variation in angle of incidence of the tail-plane on certain aircraft under all conditions of flight. It can operate normal working loads of 3000 to 5000 lb. and is capable of dealing with maximum working loads of up to 11,200 lb. in compression and 14,800 lb. in tension.

to the travel of the main stroke provided by the ball nut, which extends forwards.

4. No limit switching is incorporated in this actuator. The switches are fitted to the aircraft structure and form part of the aircraft electrical system. The actuator is, however, fitted with mechanical stops so that in the event of limit switch failure, no damage is caused by excessive travel.

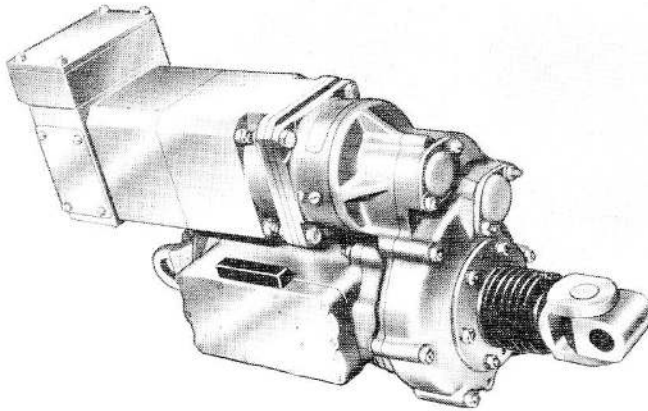

Fig. 1. General view of actuator

DESCRIPTION

General

2. The actuator comprises a two-pole, split-series field, 28 volt. d.c. motor fitted with an electro-magnetic clutch brake. The motor drives the ram through a gearbox, comprising two stages of epicyclic and two stages of spur gears. The second stage of epicyclic gears has a slipping annulus clutch, which slips, should the load reach a figure between 15,000 lb. and 16,000 lb., depending upon its setting. Damage to the motor or aircraft structure is thus prevented if overloads are imposed.

3. The last pinion of the second train of spur gears is attached to the main drive shaft (*fig. 2*), which has an external ball thread and an internal acme thread. The external thread drives a ball nut, while the internal thread drives an auxiliary drive shaft that is splined and has an acme thread upon it. This shaft extends rearwards, so providing an increased actuation stroke; this is in addition

Housing and covers

5. The actuator housing comprises a series of alloy castings. The motor frame houses the field windings, the pole pieces and the armature. The commutator and brushgear, however, are housed in a separate casting which has side covers and a base cover to facilitate inspection; a terminal box is fitted on top of this casting.

6. The brake housing is fitted to the drive end of the motor, to which in turn is fitted the drive-end, end plate.

7. Four bolts pass through the rear casing assembly of the gearbox, the drive-end, end plate and the flange of the brake housing. A further four bolts secure the motor housing to the brake housing, thus forming a rigid mounting for the motor to the gearbox.

8. The gear trains are enclosed in a housing made up of the rear casing and front casing

RESTRICTED

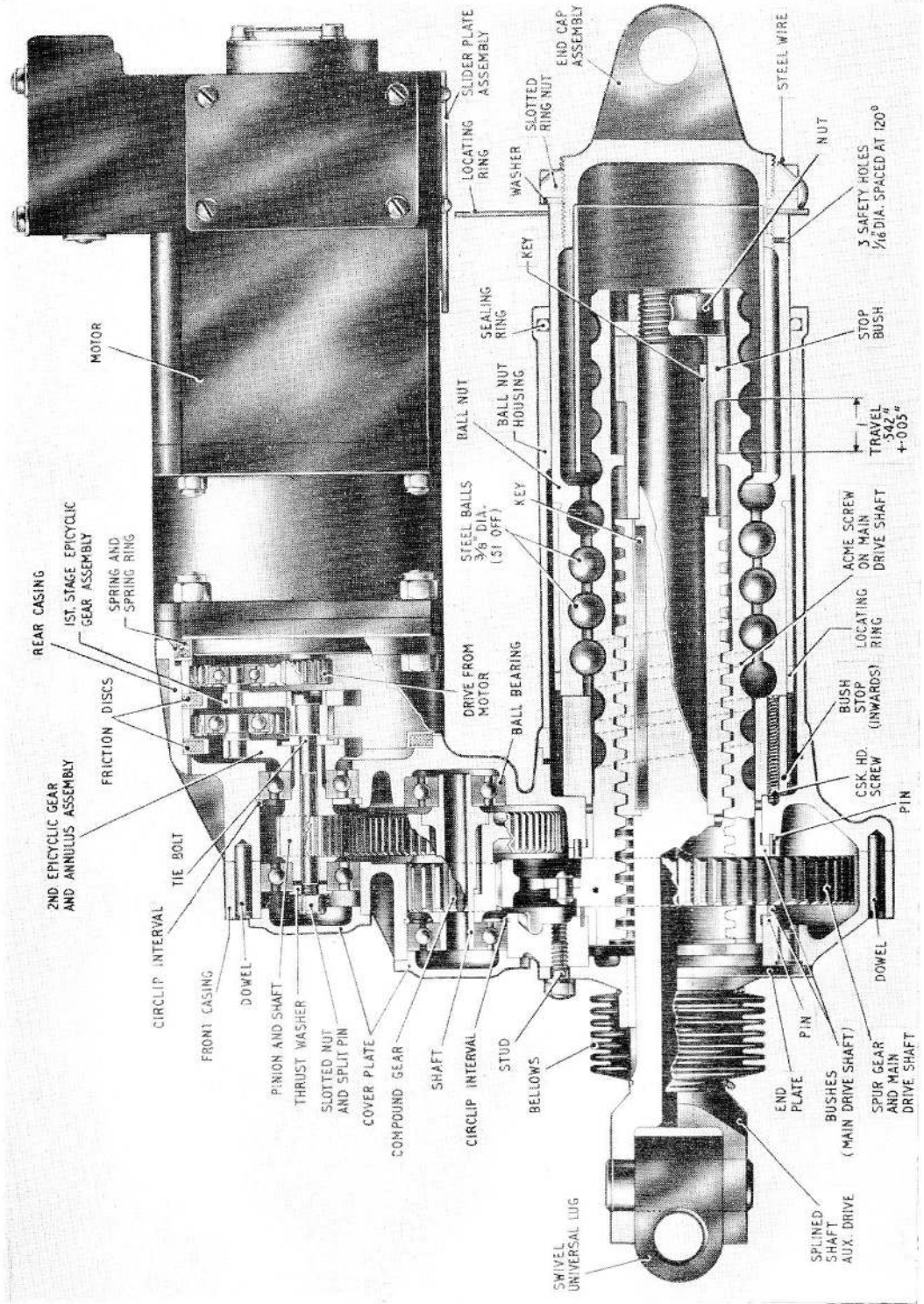

Fig. 2. Sectional view of actuator

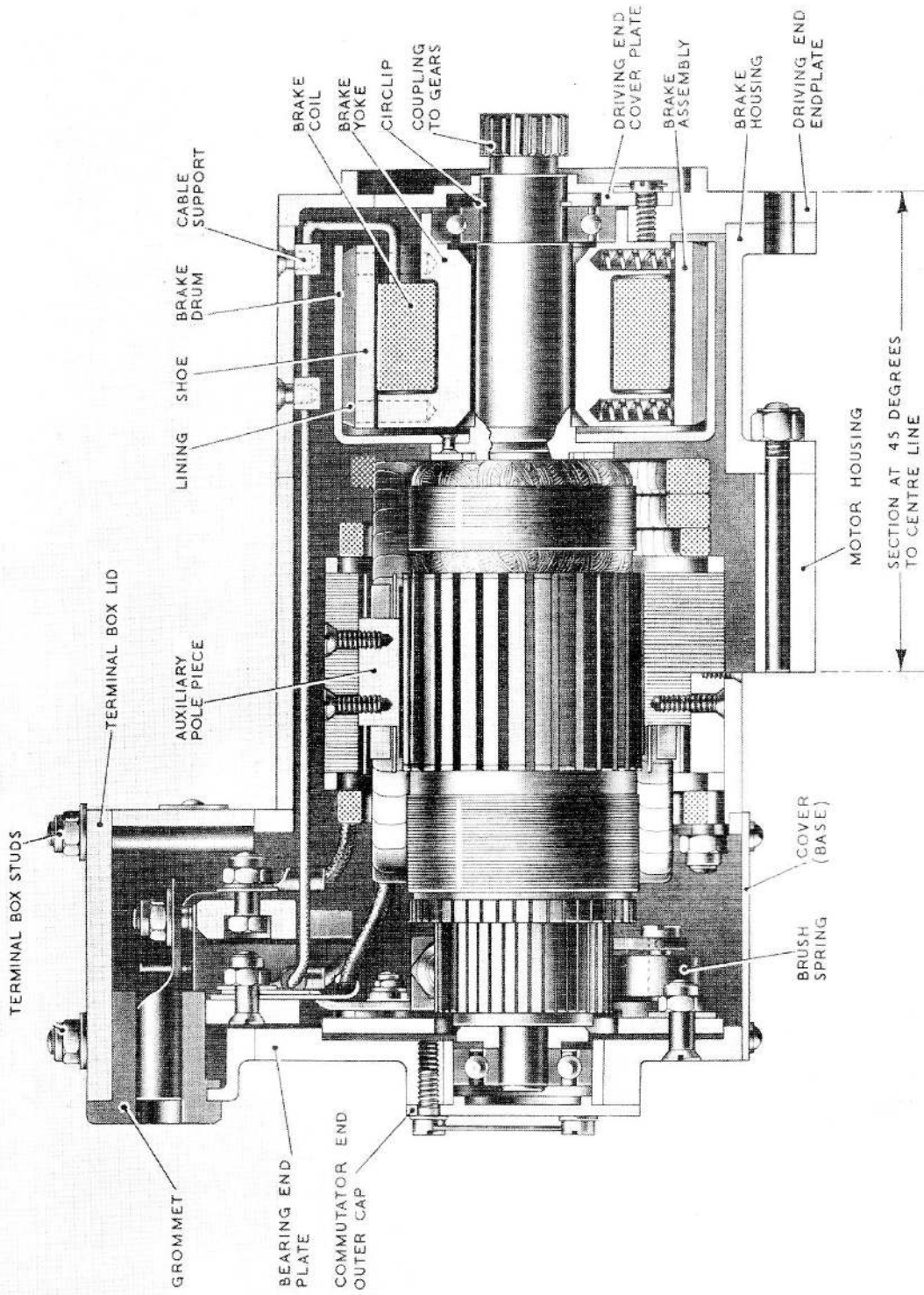

Fig. 3. Sectional view of motor

RESTRICTED

and, together, form the structure that connects the motor to the ball nut housing. The acme screw thread extends through the end plate of the front casing.

9. The ball nut (or ram) housing encloses the ball nut, the main drive shaft and the potentiometer assembly. A sealing ring is fitted at the end of the housing and is held in position by a washer and circlip.

10. All the working parts are thus fully enclosed, though readily accessible for routine inspection, without resort to dismantling.

Motor and brake assembly

11. The motor is a 28 volt machine, of 550 watts input, and operates at 11,000 r.p.m. The field windings are of the split series type, four coils being wound on two pole pieces in such a way that one coil on each pole is in operation when the actuator is extending, the remaining two coils being used to retract the actuator.

12. To ensure good commutation under most operating conditions, the motor is fitted with auxiliary and compensating windings (fig. 4); the later also serves as a safeguard in the event of sudden overloading of the motor.

13. The yoke and main pole pieces are integral, being made up of one set of laminations. The auxiliary poles, however, are of wrought iron and each is secured to the yoke by two 4 B.A. csk. hd. screws.

14. Two brushes are fitted, each is mounted in a gun metal brush box that is pivoted at its end. The boxes are, in turn, mounted upon a moulded brush rocker. Pressure on the brushes is maintained, in each instance by a flat coiled spring, one end of which bears on top of the brush. The grade of brush used is E.G.O. (HAM).

15. Two Bakelite fabric terminal boards are screwed to the terminal box and are separated by two spacing sleeves.

16. The armature shaft which is supported in ball bearings, also supports the brake drum. The drive end plate is secured to the

brake end assembly by three 4 B.A., $\times \frac{1}{2}$ in. csk. hd. screws.

17. The brake is of the electro-magnetic type and has four full-lift shoes, each of which is normally held against the brake drum by four helical springs. As the brake coil is connected in series with the motor field windings, the shoes and linings are held clear of the drum and against the yoke when either of the motor field coils are energized. The brake linings are secured to the shoes by "Redux". The wrought iron brake shoes are each located, with respect to the yoke, by two pins which engage with two holes drilled in the shoe.

Gearbox

18. The reduction gear assembly comprises two trains of epicyclic gearing and two of spur gears. The epicyclic trains are located in the rear casing.

19. The sun pinion of the first epicyclic train is integral with the motor armature shaft, while the planet gears are mounted on spindles which are riveted to the planet carrier. The sun pinion of the second epicyclic train is also secured to this carrier.

20. The annulus gear of the second epicyclic train acts as a slipping clutch and safeguards the actuator and motor in the event of overloading. The clutch setting can be altered if the number of clutch springs is varied.

21. Passing through the sun pinion of the second epicyclic train is a tie bolt; this bolt bears against a thrust washer that seats in the planet carrier of the second epicyclic train. The bolt then passes through the shaft of the first spur gear pinion which mates with an internal gear on the planet carrier of the second epicyclic train. A nut on the end of the tie bolt secures and locates these parts.

22. The pinion and shaft of the first spur train is supported at both sides of the pinion by a ball bearing. End-play is prevented by a clip that locates the bearing which is nearest to the epicyclic gears. The other bearing is located by the shoulder on the pinion and shaft and is held in position by a thrust washer and the nut on the end of the tie bolt.

23. The pinion of the first spur gear mates with a pinion on the compound gear to form the first spur gear train. The other pinion of the compound gear mates with a pinion attached to the main drive shaft, thus completing the second stage of the spur gearing.

24. The compound gear is supported by two ball bearings. One of these is located in the rear casing assembly and the other in the front casing assembly. The bearing in the front casing assembly is held in position by a blanking cover and a clip.

Drive shafts and ball nut mechanism

25. The main drive shaft is of steel and is supported by bushes which fit into the front and rear casing assemblies. On the outside of the main drive shaft is cut a high-efficiency ball thread and, on the inside, is cut an acme thread.

26. The ball nut, which converts the rotary movement of the main drive shaft into a linear movement, is fitted with a re-circulating device. This comprises fifty-one $\frac{3}{8}$ in. dia. steel balls which provide an almost frictionless drive throughout the stroke.

27. The torque reaction set up by the rotating parts and transmitted to the ball nut, and thence to the end cap assembly, is absorbed by the aircraft structure. At the opposite end of the actuator, torque reaction, transmitted through the acme thread to the splined shaft, is absorbed by the splines on the end plate, which correspond to those on the shaft.

28. A locating ring is fastened to the ball nut and prevents it rotating accidentally, when the unit is not held in some form of mounting.

29. The acme thread is keyed to the spline shaft and engages with the internal acme thread cut on the main drive shaft. On the inner end of the splined shaft is keyed a stop bush, held in position by a flanged nut. This bush acts as a mechanical stop in the event of limit switch failure when the actuator is extending. Further extension of the ball nut is prevented, when a mechanical stop on the inside of the main drive shaft comes into contact with the stop bush. The clutch then slips.

30. If the limit switch fails when the actuator is retracting, the end of the ball nut comes into contact with a stop bush, which fits in the rear casing assembly. Further movement of the ball nut is thus prevented and the clutch slips.

31. The splined shaft, providing extra extension through the medium of the acme screw, is protected from the ingress of dirt by a rubber, bellows-type, gaiter, held in position by spring clips. Hence no foreign matter is allowed to enter the splines when the actuator is in the extended position.

32. Two mounting points for the actuator are provided. The first is at the ball nut drive end and comprises a mounting lug which is part of the end cap assembly. The second mounting point is a swivel lug, which forms part of the splined shaft, at the acme screw end of the machine. It should be noted that the end cap assembly screws into the internal thread which is cut on the ball nut.

Limit switches

33. No limit switches are fitted in this type of actuator; instead, they are incorporated in the variable incidence tailplane of the aircraft. Consequently, the actuator should not be operated unless it is installed, either in an aircraft, or in a test rig incorporating suitable limit switches.

Potentiometer

34. In certain installations the position of the ram is constantly shown by a Desynn indicator which is connected to a potentiometer in the ram housing of the actuator.

35. Between the two coils of the potentiometer moves a sliding contact. Small springs, which hold the contact surface against the coils, ensure a good contact area. The sliding contact is moved along the coils by a carrier screwed to the ball nut assembly.

36. Full stroke of the actuator is indicated by a corresponding movement of the indicator needle. If the actuator motor supply circuit is broken, the needle of the indicator moves immediately to its "pull off" position, which is clear of the working part of the scale.

RESTRICTED

INSTALLATION

37. The actuator is secured to the aircraft structure by two mounting lugs, one fitted at each end of the actuator. The lug that is a part of the end cap assembly is adjustable, being fitted with a locking ring nut, and screws into the internal thread which is cut on the ball nut. Consequently, it is possible, by slackening off the lock nut, to move the mounting lug in or out, as required. Such action permits the distance between the centres of the two mounting lugs to be altered. This, in turn, increases or decreases the effective extended length of the actuator.

38. The distance between the centres of the mounting lugs is normally 14.615 in. when the actuator is retracted, and 16.375 ± 0.125 in. when the actuator is extended. This small tolerance (± 0.125 in.) is obtained by altering the position of the ram end mounting lug, as explained in the previous paragraph.

39. It is possible to slacken the mounting lug at the ram end to a point where there is insufficient effective thread on the lug to carry the loads imposed upon it during normal operation. Accordingly, the following precaution must be observed. On the ram are three safety holes (fig. 2). Always ensure that the mounting lug is screwed on the ram sufficiently far as to cover these safety holes.

40. The alignment of the mounting lugs should be inspected before the actuator is installed in an aircraft. During installation

the actuator should be operated at a reduced voltage of 16 volts.

41. During fitment of the actuator to the aircraft it is possible for the ball nut to rotate through one or more of its locking serrations and thereby, inadvertently and unnoticed, vary the stroke by multiples of 0.055 to 0.060 in.

42. To obviate this an index line has been painted along the ball nut housing and the exposed portion of the ball nut, this will enable a quick inspection to be made for inadvertent ball nut rotation, and restore it to its correct position.

Note . . .

It must be appreciated that this will only apply if the inadvertent rotation is less than, or, equal to 180 degrees.

43. The index line should be painted on with the ram fully retracted so as to ensure that paint does not get on to the ram casing.

44. A practical wiring diagram is provided in fig. 4. The motor terminals are, in fact, numbered 1, 2 and 3, corresponding to common, extend and retract, respectively, on this illustration.

45. The connections for the indicator circuit are made by the five core cable which is connected to the potentiometer.

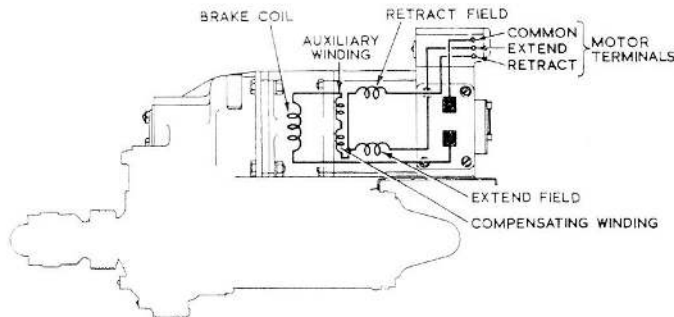

Fig. 4. Practical wiring of diagram

- Red — Positive } 24 volt supply to
- Blue — Negative } Potentiometer
- White — No. 1 terminal on Desynn indicator
- Yellow — No. 2 terminal on Desynn indicator
- Green — No. 3 terminal on Desynn indicator

46. The potentiometer assembly, of which the terminal block is an integral part, is fitted to the side of the ram housing. It should be noted that the Desynn indicator pointer should move in a clockwise direction when the actuator extends.

OPERATION

47. In the following text it is assumed that the actuator is installed in an aircraft with limit switches connected in the supply circuit. Accordingly, when the actuator is fully extended, the "extend" limit switch will be open and the retract limit switch closed.

48. When the supply is switched on, the brake coils will be energized, so lifting the brake shoes clear of the brake drum and holding them hard against the yoke. The relevant pair of motor coils will be energized and the armature will rotate.

49. As the sun pinion of the first epicyclic gear train is integral with the armature it will rotate also, thus setting the epicyclic gear trains in motion. These gear trains in turn rotate the spur gears. The last pinion of the spur gear trains is secured to the main drive shaft. Rotary motion is therefore imparted

to the drive shaft. As the shaft rotates it causes a linear movement of the ball nut and splined shaft, both of which retract.

50. As soon as the ball nut leaves the fully extended position the "extend" limit switch closes. When this occurs, both limit switches are closed and the actuator may be reversed, simply by altering the position of the circuit selector switch, so that the "extend" field of the motor is energized.

51. When the actuator reaches its fully extended or retracted position, or, if the electrical supply is switched off manually during either stroke, the brake will be de-energized. Consequently, the brake shoes and linings are forced against the brake drum by the action of the loaded brake springs.

52. The armature is brought to rest, and hence that of the other rotating parts, so bringing the ball nut to a standstill, with an overrun of less than 0.075 in., at any desired position during the stroke, or, at the limits of the stroke.

Note . . .

Performance curves of tensile and compressive loading are shown in fig. 5.

SERVICING

General

53. The actuator is to be inspected and serviced in accordance with, and at the periods specified in, the appropriate Servicing Schedule.

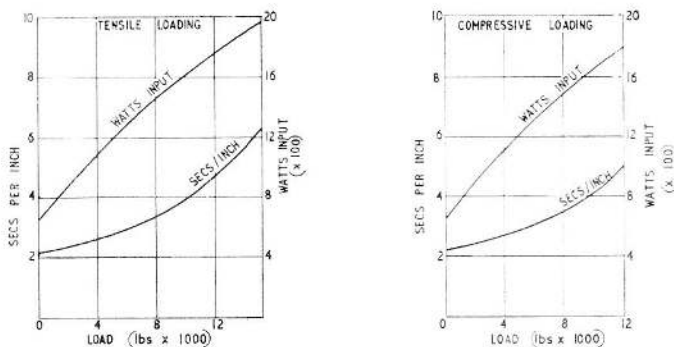

Fig. 5. Performance curves of tensile and compressive loading

RESTRICTED

Brush gear

54. Access to the brushes for inspection is by removal of the motor side covers. The brush boxes and brushes should be thoroughly cleaned and any accumulation of carbon dust blown out with dry compressed air. The brushes should slide easily in their boxes.

55. Worn brushes must be replaced with new before their maximum wear limit is reached, so ensuring that the actuator will operate satisfactorily until the next inspection. The minimum overall brush length permissible is $\frac{1}{2}$ in. If brush renewal is necessary, only brushes of grade E.G.O. (HAM) should be used; they must be bedded down to the contour of the commutator to give a contact surface of at least 80 per cent of their cross-sectional area.

56. The brush spring tension should be checked and should be between 15 and 21 oz. In checking the spring tension a suitable spring balance must be used. The balance is hooked beneath the brush spring at the point where it bears on the brush. The reading is taken when the brush spring is lifted, in a direction parallel to the centre-line of the brush, just clear of the brush.

Potentiometer

57. Any servicing carried out must be confined to generally cleaning the assembly and changing or reversing the contact inserts.

58. After removing the sealed cover clean all internal parts with lead-free white spirit. It may be necessary to clean the contact area of the potentiometer and this should be done using a very fine abrasive paper. Application of pressure of this paper to the rod should be applied by a flat strip of steel or wood. This will ensure that the cleaned surface will be level and not consist of numerous ripples. Reversing the contacts will also assist, but should both sides have been used, a new set must be fitted. While the cover is removed ensure that the contact carriers are a free fit in the fork and that the pressure spring is not distorted.

Lubrication

59. The actuator is lubricated during manu-

facture and should require no further attention, except at the periods laid down in the appropriate Servicing Schedule.

Eye end safety

60. It is noted that this type of actuator now has three holes for fork end safety inspection. It has been found that on removal of the fork end, there are four blobs of solder at the end of the thread at the junction with the sleeve. These blobs of solder can coincide with a safety hole (fig. 2), and indicate the fork end in safety, when in fact it is not (*refer to para. 39*).

61. When inspecting for fork end safety at least two safety holes must be visually examined, one hole of which must be clear, since the safety holes are spaced at 120 degrees and the solder blobs at 90 degrees.

62. After adjustment of the fork end, a $\frac{1}{16}$ in. diameter pin should be inserted in the safety hole.

63. If the pin is found to penetrate to a depth exceeding 0.1835 in., it should be immediately assumed that the fork end is "out of Safety". Should this be the case, re-adjustment should be repeated until the correct centres are obtained and on re-insertion of the $\frac{1}{16}$ in. diameter pin, the fork end is found to be in "Safety".

Final inspection

64. Ensure that all nuts, screws and locking devices are secure, also that the electrical connections are tight and free from corrosion.

Insulation resistance test

65. Using a 250 volt insulation resistance tester, measure the insulation resistance between the plug pins and earth; it must not be less than 2 megohms.

66. Due to the increased moisture prevalent in an aircraft when in service, after the actuator has been installed, the minimum permissible insulation resistance must not be less than 50,000 ohms.

This file was downloaded
from the RTFM Library.

Link: www.scottbouch.com/rtfm

Please see site for usage terms,
and more aircraft documents.

