

Chapter 85

ACTUATORS, ENGLISH ELECTRIC, TYPE AE4010 SERIES

LIST OF CONTENTS

	<i>Para.</i>		<i>Para.</i>
<i>Introduction</i>	1	<i>Potentiometer</i>	14
Description	2	<i>Switch striker mechanism</i>	15
<i>Housing</i>	3	Installation	16
<i>Motor and brake assembly</i>	5	Operation	18
<i>Limit switches</i>	9	Servicing	24
<i>Gearbox, drive and ram</i>	10	<i>Insulation resistance test</i>	30

LIST OF ILLUSTRATIONS

	<i>Fig.</i>		<i>Fig.</i>
<i>General view of typical actuator</i>	1	<i>Sectional view of motor and brake assembly</i>	3
<i>Sectional view of actuator</i>	2	<i>Wiring diagram</i>	4

LIST OF APPENDICES

	<i>App.</i>		<i>App.</i>
<i>Actuator, English Electric, Type AE4010, Mk. 2</i>	1	<i>Actuator, English Electric, Type AE4011, Mk. 3</i>	3
<i>Actuator, English Electric, Type AE4011, Mk. 2</i>	2	<i>Actuator, English Electric, Type AE4012, Mk. 3</i>	4
		<i>Actuator, English Electric, Type AE4015, Mk. 2</i>	5

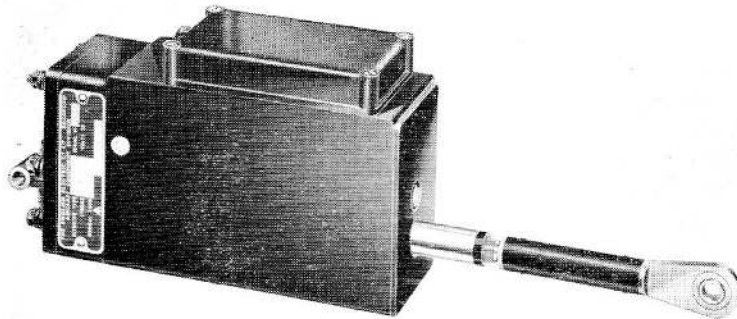

Fig. 1. General view of typical actuator

RESTRICTED

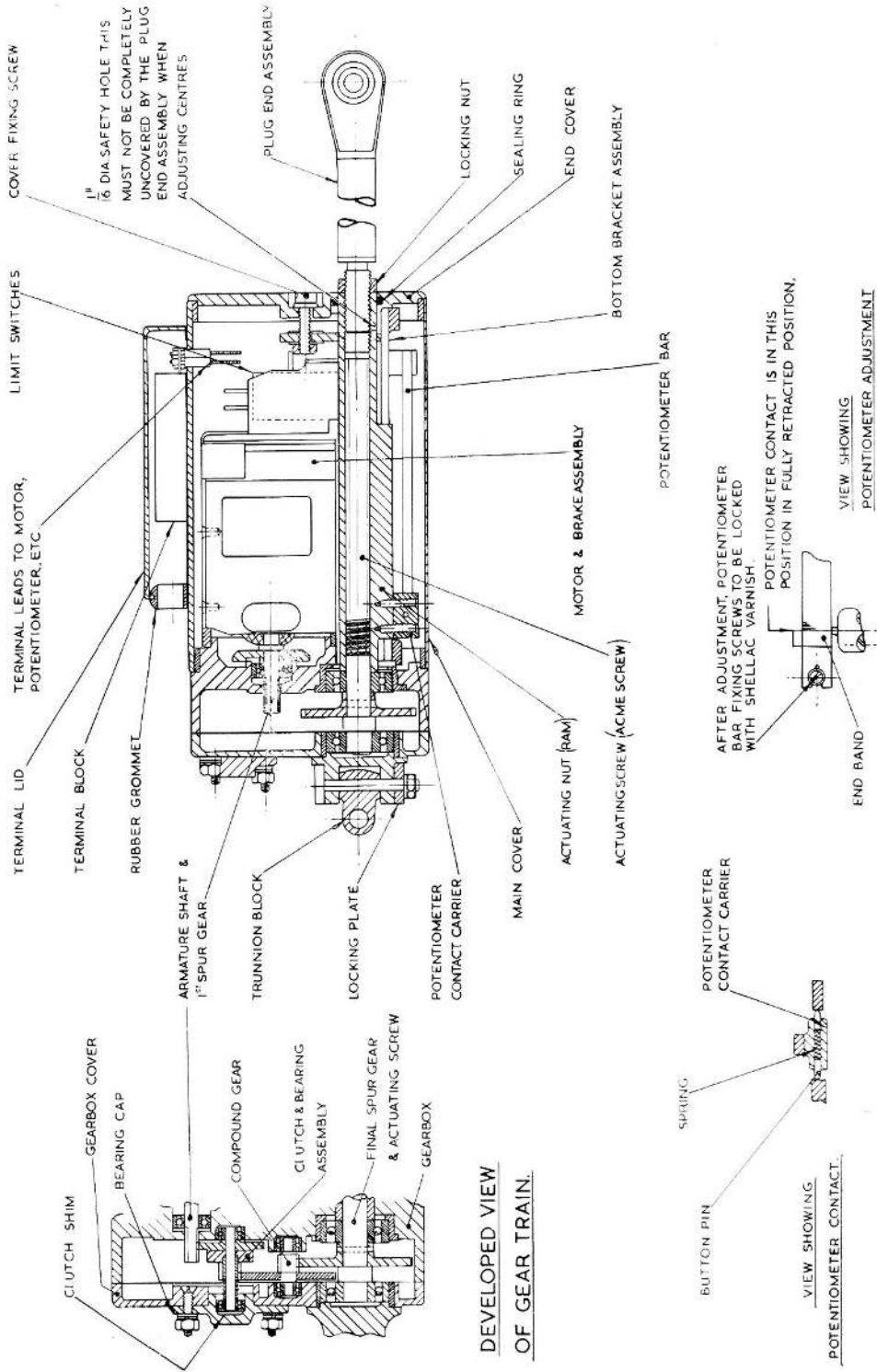

Fig. 2. Sectional view of actuator

Introduction

1. The English Electric actuators of the AE4010 series follow the general design described in this Chapter. The actuator described here is the AE4010, Mk. 3 and is typical of the series. For specific details of actuators in this series, reference should be made to the Appendices to this Chapter. The linear actuator, Type AE4010, Mk. 3, has been designed to provide remotely controlled linear motion against tensile and compressive loads up to a maximum of 150 lb.

DESCRIPTION

2. The actuator consists of a split field, series wound, 28V d.c. motor. It is fitted with an electro-magnetic brake to prevent excessive overrun after the limit switches have broken the motor circuit. The drive from the motor to the ram is provided by an arrangement of spur gearing which incorporates a slipping clutch. The final spur gear is secured by a tapered pin to an acme screw, which, through its mating thread on the ram, provides linear movement.

Housing

3. The actuator housing, comprises a series of covers (together with the gearbox). The light alloy main cover is of rectangular cross section reinforced at both ends by strips of alloy sheet. It houses the motor and brake assembly, the ram mechanism, the potentiometer assembly and the limit switches; it is enclosed at one end by the gearbox and at the other end by an end cover through which the ram passes.

4. A 2 B.A. screw secures the end cover. This is tightened to a torque of 5 lb. in. to avoid distortion and misalignment. The gearbox also has an end cover, to which is attached the trunnion block mounting lug.

Motor and brake assembly

5. The motor is a two pole, split field, series wound 28V d.c. machine, the output is 3.7W at 14000 rev/min. The change of rotation is effected by external switch gear.

6. The two alloy brush boxes are mounted on a moulded rocker, which is adjustable to set the brushes on the correct neutral axis. The brushes are held against the commutator by coiled springs bearing on brush fingers.

7. A single plate disc type electro-magnetic brake, is connected electrically in series with the armature, and mechanically to the motor frame at the commutator end.

8. The external supply is connected via six-way terminal block situated on the main cover. This includes connections to the potentiometer.

Limit switches

9. The limit switches are of the single pole, changeover type, and are secured on a bracket mounted on the bottom bracket assembly, which incorporates the potentiometer assembly and the switch striker mechanism.

Gearbox, drive and ram

10. The gearbox and gearbox cover form the housing for the rear drive from the motor to the ram. Both gearbox and gearbox cover are alloy die castings with ball races inset in them. On these ball races are mounted the spur gears forming the gear drive to the ram.

11. The first pinion of the gear drive is integral with the armature shaft. This drives direct on to the slipping clutch input gear, and, if no slip occurs, the output pinion of clutch drives a compound gear which in turn meshes with the final spur gear of the train. This final gear is secured to the acme thread by a tapered pin and, through its mating thread on the ram, provides linear movement.

12. Screwed in the end of the ram is the plug end assembly. This is used primarily as one of the mounting points (the other being the trunnion block mentioned in para. 4), and secondarily as a means of adjusting the retracted centre distance.

13. Mechanical stops are fitted in this

RESTRICTED

actuator as a safety precaution in the event of limit switch failure. If a limit switch fails, the ram forces its way against a mechanical stop and the clutch slips. The actuator is designed to absorb any torque reaction set up when this occurs.

Potentiometer

14. The potentiometer is used as a position transmitter, fitted for use with a remote ratiometer type indicator. Between the train coils of the potentiometer moves a sliding contact. Small springs hold the contact against the coils, thus providing constant pressure and good electrical contact. The sliding contact is moved along the coils by a carrier attached to the ram.

Switch striker mechanism

15. The switch striker mechanism is incorporated in the bottom bracket assembly; it comprises two slider bars on which the striker barrels move. Screwed and locked into a flange on each of these striker barrels is an adjusting screw, with which the stroke is correctly set. The striker barrels are moved along the slider bars by means of pins set in the ram. The pins are permanently set a fixed distance apart so as to give the correct stroke.

INSTALLATION

16. The actuator is secured to the aircraft structure at mounting points. The plug end assembly is adjustable; it is fitted with a locknut and screws into the internal thread cut on the ram. By slackening the locknut, adjustment may be made to the retract centre distance, by screwing the plug end assembly in, or out, as required.

Note . . .

It is possible to screw out the plug end assembly to a point at which there is insufficient effective thread length on the plug end to carry the loads imposed upon it during normal operation. Accordingly, should any adjustment be required, the following procedure must be adopted. On the ram is a safety hole (fig. 2). Always ensure that the screwed portion of the plug end assembly is screwed sufficiently in the ram to cover this hole. To check this, a

piece of $\frac{1}{8}$ in. dia. wire should be pushed through the safety hole. If it penetrates to a depth greater than $\frac{1}{8}$ in., the plug end assembly is not screwed far enough in the ram.

17. The alignment of the mounting lugs should be checked before the actuator is installed in an aircraft. The distance between the retracted centres of the mounting points and the travel over the normal working stroke of the various actuators in the series, is given in the Leading Particulars to the Appendices.

OPERATION

18. With the actuator installed in the aircraft, and the external wiring connected up, the operation is as follows with the ram initially in the fully retracted position.

19. In the fully retracted position the retract limit switch will be open and the extend limit switch will be closed.

20. When the supply is switched on, the brake coil will become energized and will pull the brake shoe away from the brake disc; also the appropriate motor field will become energized and the armature will rotate, thereby setting in operation the gear drive to the ram, and extending the ram.

21. As soon as the ram leaves the fully retracted position, the switch striker barrel will move along the slider bar away from the retract limit switch, thus allowing it to close.

22. Now both limit switches are in the closed position, and the actuator may be reversed by altering the position of the remote circuit selector switch.

23. When the actuator reaches the fully extended position the other switch striker barrel causes the extend limit switch to open, and the supply to the motor and brake will be broken. The brake shoe will be forced against the brake disc under the action of a helical spring and the motor will come to an almost instantaneous stop. Should an overload occur at any point during the stroke, the clutch will slip and the ram will come to rest.

RESTRICTED

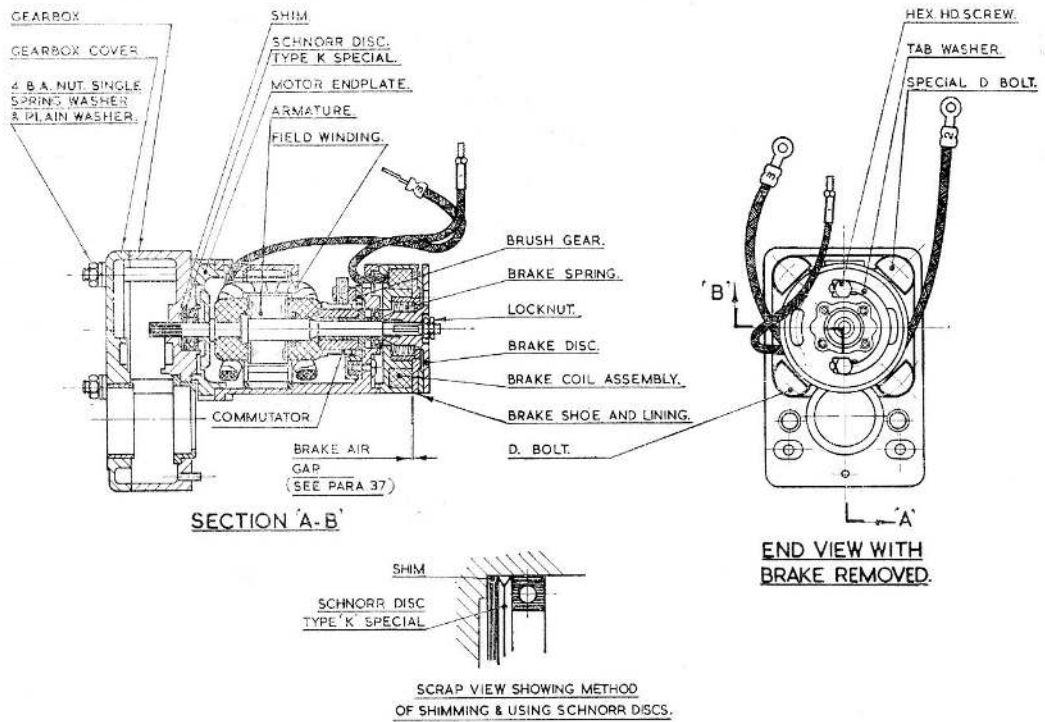

Fig. 3. Sectional view of motor and brake assembly

SERVICING

24. The actuators should be inspected and serviced in accordance with, and at the periods specified in, the appropriate Servicing Schedule. For routine inspections, the external nuts, bolts and screws should be checked for security. The wiring should be checked for fraying leads, corrosion at the terminals, and security of the terminal screws and lead ends.

25. Brushes should be renewed at the periods prescribed in the relevant Servicing Schedule, and whenever examination reveals that they will not remain serviceable for the period that must elapse before the next servicing. The brush spring tension should be checked with a suitable spring balance, and the values obtained should be within the limits quoted in the Leading Particulars.

26. Brake lining wear should be checked

by feeler gauges between the brake shoe and the brake yoke. This gap should be within 0.004 — 0.015 in.

27. The potentiometer contact surfaces should be inspected for freedom from dirt, grease, and oxides forming on the coils; should there be any evidence of these, the surfaces should be cleaned using wood backed crocus paper. After cleaning with crocus paper, any accumulation of dust should be carefully blown away with dry compressed air.

28. Should the servicing require the removal of the potentiometer bars, the following procedure should be adopted when replacing them. The actuators should be run on to the retract limit position, i.e., their fully retracted position. The potentiometer bar should be adjusted so that the potentiometer contact is positioned at the junction of the end band and windings.

RESTRICTED

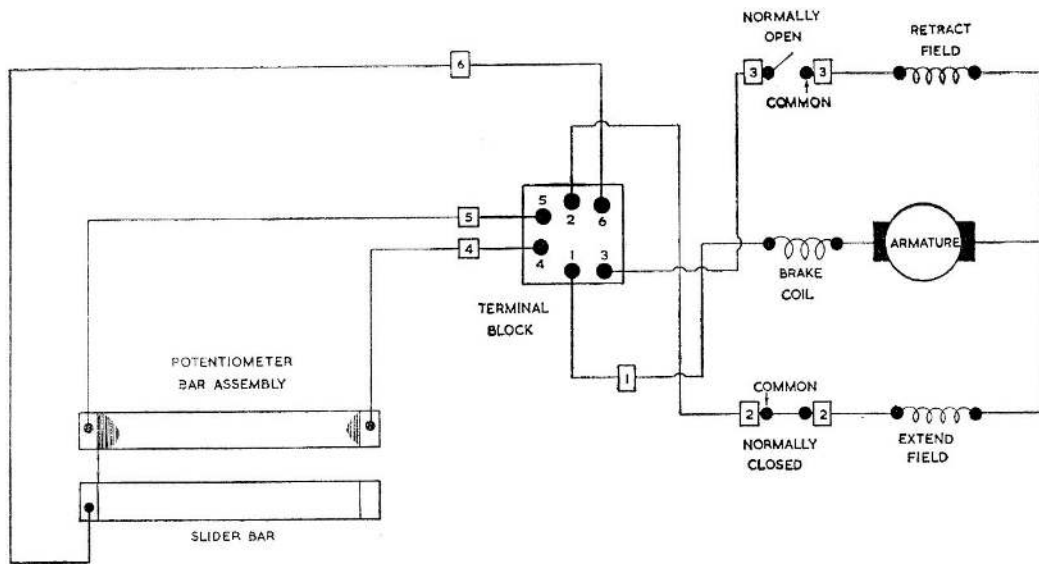

Fig. 4. Wiring diagram

With the actuator fully assembled, the resistance between terminals 5 and 6 should be zero (still in fully retracted position), and between terminals 4 and 6 the resistance should be $500 \text{ ohms} \pm 7\frac{1}{2}\%$. With the actuator on the extend limit switch, the resistance between terminals 5 and 6 should be $133 \text{ ohms} \pm 7\frac{1}{2}\%$. After adjustment the potentiometer bar fixing screws should be locked with shellac varnish.

Note...

When replacing the armature the schnorr discs and shims, fitted between the gearbox housing and drive end bearing, are to be fitted in a back-to-back sequence as shown in fig. 3.

29. The actuator is lubricated during manufacture and should require no further

attention except at the periods laid down in the appropriate Servicing Schedule. The motor drive pinion and gear, and the lead screw and intermediate gear should be lubricated with grease XG-275. The bearings should be packed to $\frac{1}{3}$ full with the same lubricant.

Note...

It should be noted that this actuator contains mated assemblies.

Insulation resistance test

30. Using a 250V insulation resistance tester, measure the insulation resistance between live parts and the frame. The minimum permissible insulation resistance should be not less than 50,000 ohms.

Appendix 1

ACTUATOR, ENGLISH ELECTRIC, TYPE AE4010, Mk. 3

LEADING PARTICULARS

<i>Actuator, Type AE4010, Mk. 3</i>	<i>Ref. No. 5W/2629</i>
<i>Rated voltage</i>	<i>28V d.c.</i>
<i>Maximum working load</i>	<i>150 lb.</i>
<i>Normal working load</i>	<i>100 lb.</i>
<i>Clutch slip load</i>	<i>170—340 lb.</i>
<i>Static load</i>	<i>750 lb.</i>
<i>Normal working stroke</i>	<i>0·8 in.</i>
<i>Time of stroke (on normal load at 28V d.c.)</i>	<i>8 sec.</i>
<i>Distance between centres (on retract limit switch setting)</i>	<i>10·10 in.</i>
<i>Minimum brush length</i>	<i>0·225 in.</i>
<i>Brush spring pressure</i>	<i>4 to 5 oz.</i>
<i>Brush grade</i>	<i>C.M.6 (H.A.M.)</i>
<i>Weight</i>	<i>2 lb. 13 oz.</i>

1. The actuator belongs to the same series and is identical to that described and illustrated in the main chapter.

RESTRICTED

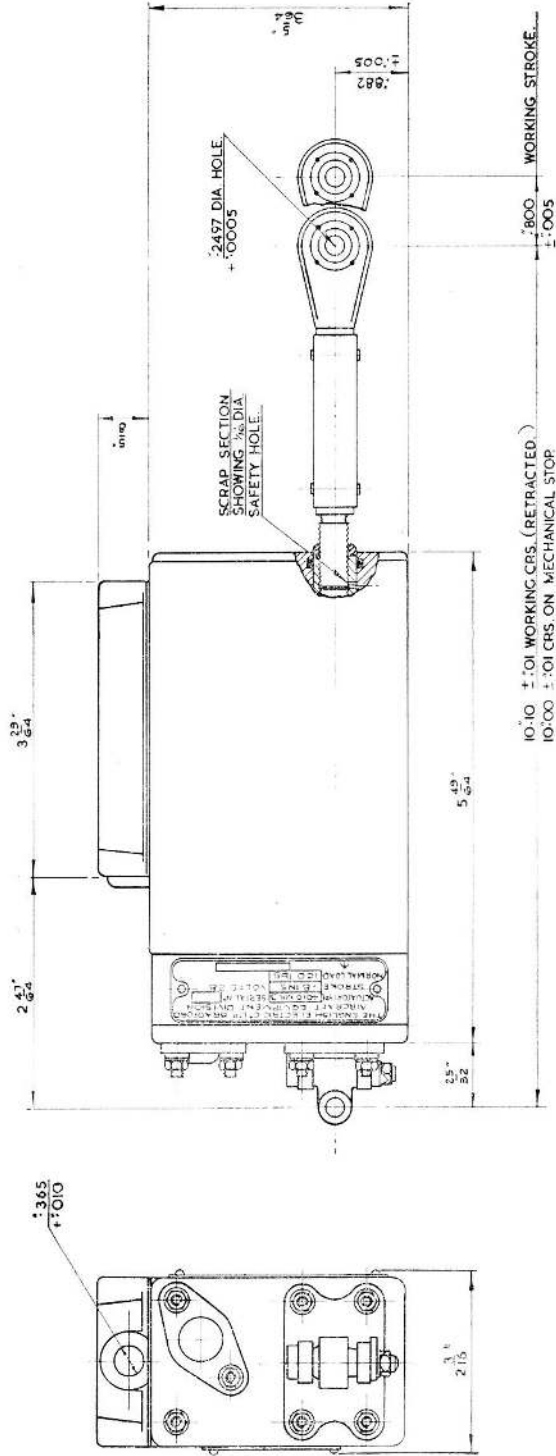
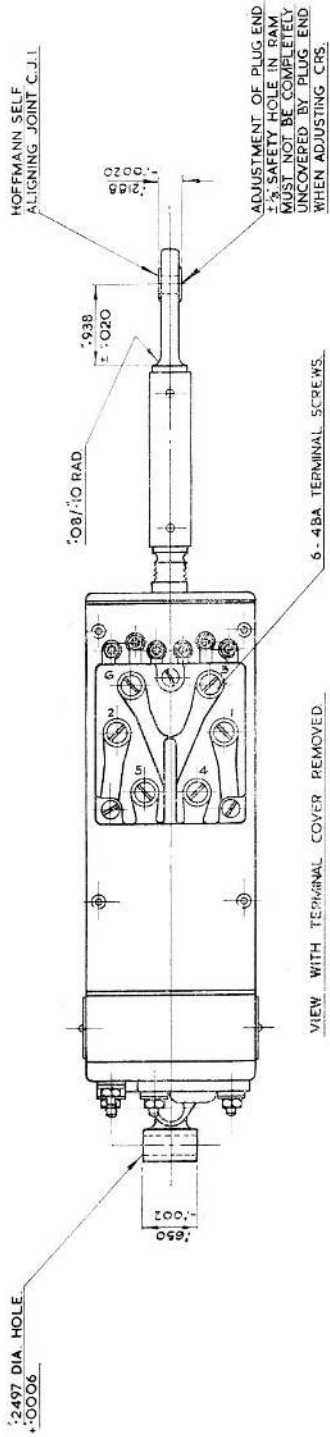

Fig. 1. Installation diagram

RESTRICTED

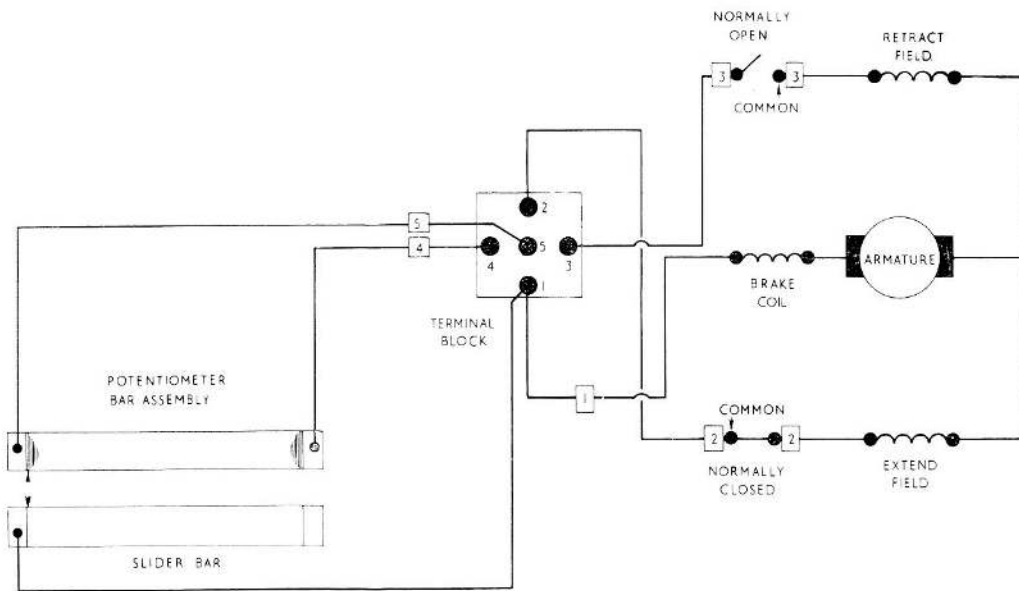

Fig. 2. Wiring diagram

(5) The static load is 400 lb.

(6) The terminal block is smaller, and is a 5-way. The negative leads from the potentiometer slider bar and the actuator

brake coil are both connected to terminal 1.

Note . . .

The speed of operation differs from the basic actuator.

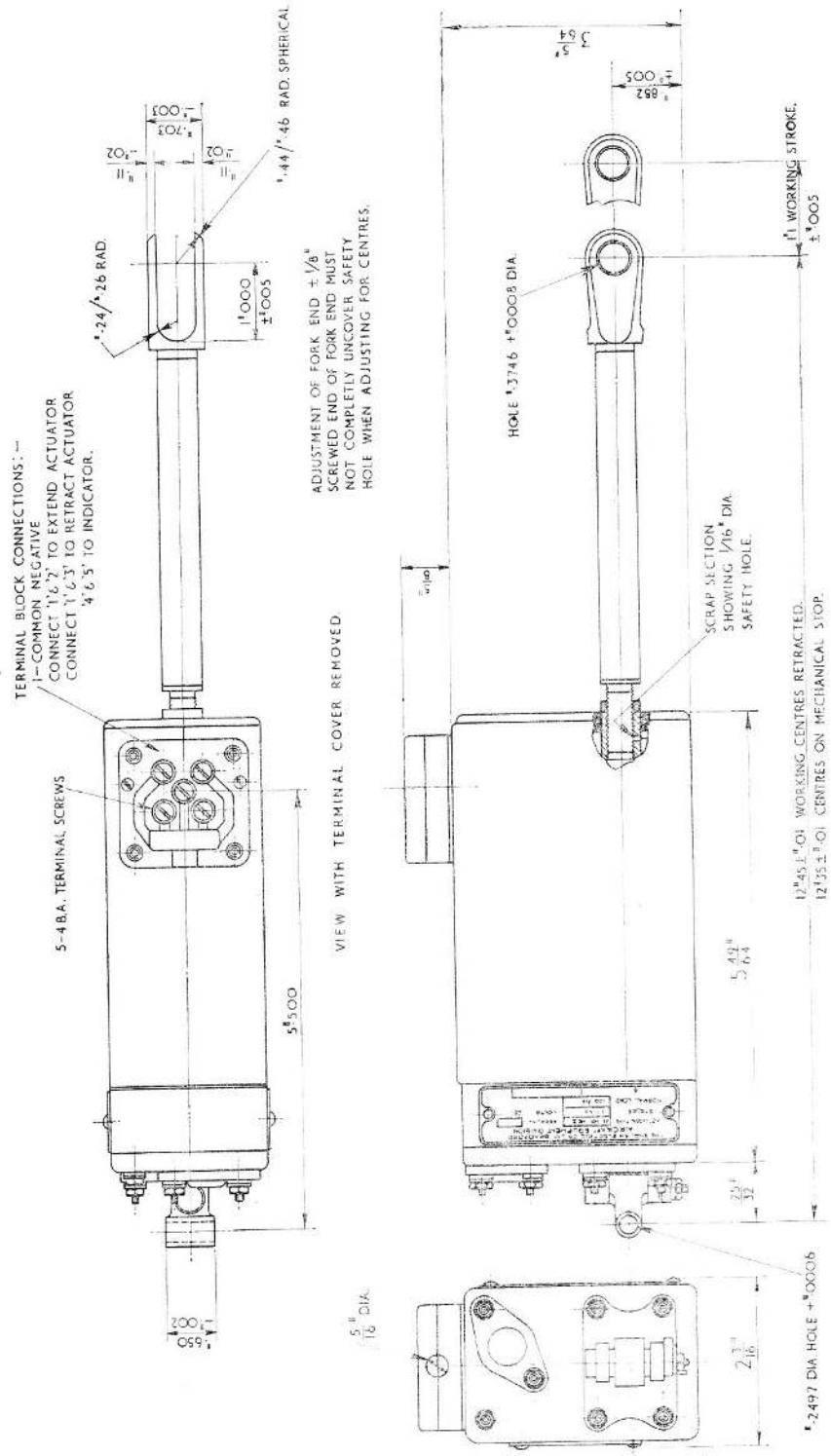

Fig. 3. Installation diagram

RESTRICTED

Appendix 3

ACTUATOR, ENGLISH ELECTRIC, TYPE AE4011, Mk. 3

LEADING PARTICULARS

<i>Actuator, Type AE4011, Mk. 3</i>	<i>Ref. No. 5W/2630</i>
<i>Rated voltage</i>	28V d.c.
<i>Maximum working load</i>	150 lb.
<i>Normal working load</i>	100 lb.
<i>Clutch slip load</i>	170—340 lb.
<i>Static load</i>	400 lb.
<i>Normal working stroke</i>	1.1 in.
<i>Time of stroke (on normal load at 28V d.c.)</i>	7 sec.
<i>Distance between centres (on retract limit switch setting)</i>	12.45 in.
<i>Minimum brush length</i>	0.225 in.
<i>Brush spring pressure</i>	4 to 5 oz.
<i>Brush grade</i>	C.M.6 (H.A.M.)
<i>Weight</i>	3 lb.

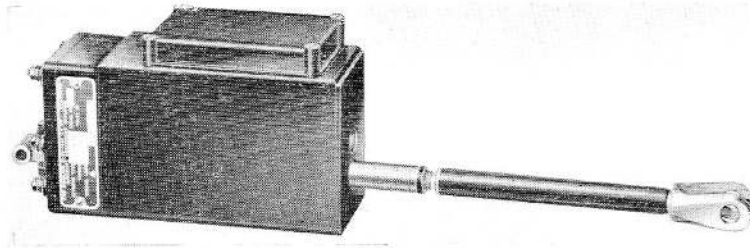

Fig. 1. Actuator, Type AE4011, Mk. 3

1. The actuator belongs to the same series as that described in the main chapter, the differences being:

- (1) The mounting point on the ram is a fork end.
- (2) The retracted centre distance between the mounting points is 12.45 ± 0.010 in.
- (3) The stroke is 1.10 ± 0.005 in.

(4) The potentiometer servicing instructions are the same as those for the actuator described in the main chapter, except that, in the extended position, the resistance between terminals 5 and 6 is 183 ohms $\pm 7\frac{1}{2}$ per cent.

(5) The static load is 400 lb.

Note . . .

The speed of operations differs from that of the basic actuator.

RESTRICTED

Appendix 4

ACTUATOR, ENGLISH ELECTRIC, TYPE AE4012, Mk. 3

LEADING PARTICULARS

<i>Actuator, Type AE4012, Mk. 3</i>	<i>Ref. No. 5W/3719</i>
<i>Rated voltage</i>	<i>28V d.c.</i>
<i>Maximum working load</i>	<i>150 lb.</i>
<i>Normal working load</i>	<i>100 lb.</i>
<i>Clutch slip load</i>	<i>250—340 lb.</i>
<i>Static load</i>	<i>1250 lb.</i>
<i>Normal working stroke</i>	<i>0.75 in.</i>
<i>Time of stroke (on normal load at 28V d.c.)</i>	<i>3.75 sec.</i>
<i>Distance between centres (on retract limit switch setting)</i>	<i>11.625 in.</i>
<i>Minimum brush length</i>	<i>0.225 in.</i>
<i>Brush spring pressure</i>	<i>4 to 5 oz.</i>
<i>Brush grade</i>	<i>C.M.6 (H.A.M.)</i>
<i>Weight</i>	<i>2 lb. 13 oz.</i>

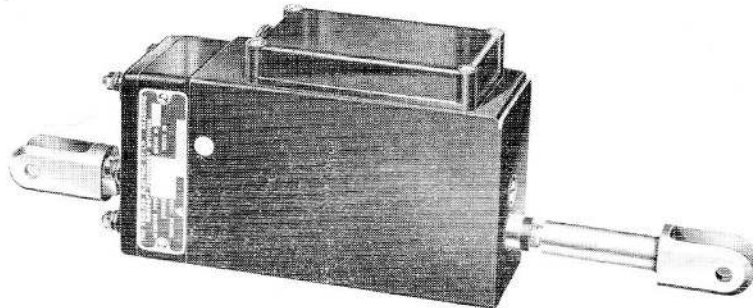

Fig. 1. Actuator, Type AE4012, Mk. 3

1. The actuator belongs to the same series as that described in the main chapter, the differences being:

- (1) The mounting points are a fork end on the ram, and an end lug on the gear-box housing.
- (2) The retracted centre distance between the mounting points is 11.625 ± 0.01 in.
- (3) The stroke is 0.750 ± 0.005 in.

(4) The potentiometer Servicing Instructions are the same as those for the actuator described in the main chapter, except that, in the extended position, the resistance between terminals 5 and 6 is 125 ohms $\pm 7\frac{1}{2}$ per cent.

(5) The static load is 1 250 lb.

Note...

The speed of operation differs from that of the basic actuator.

RESTRICTED

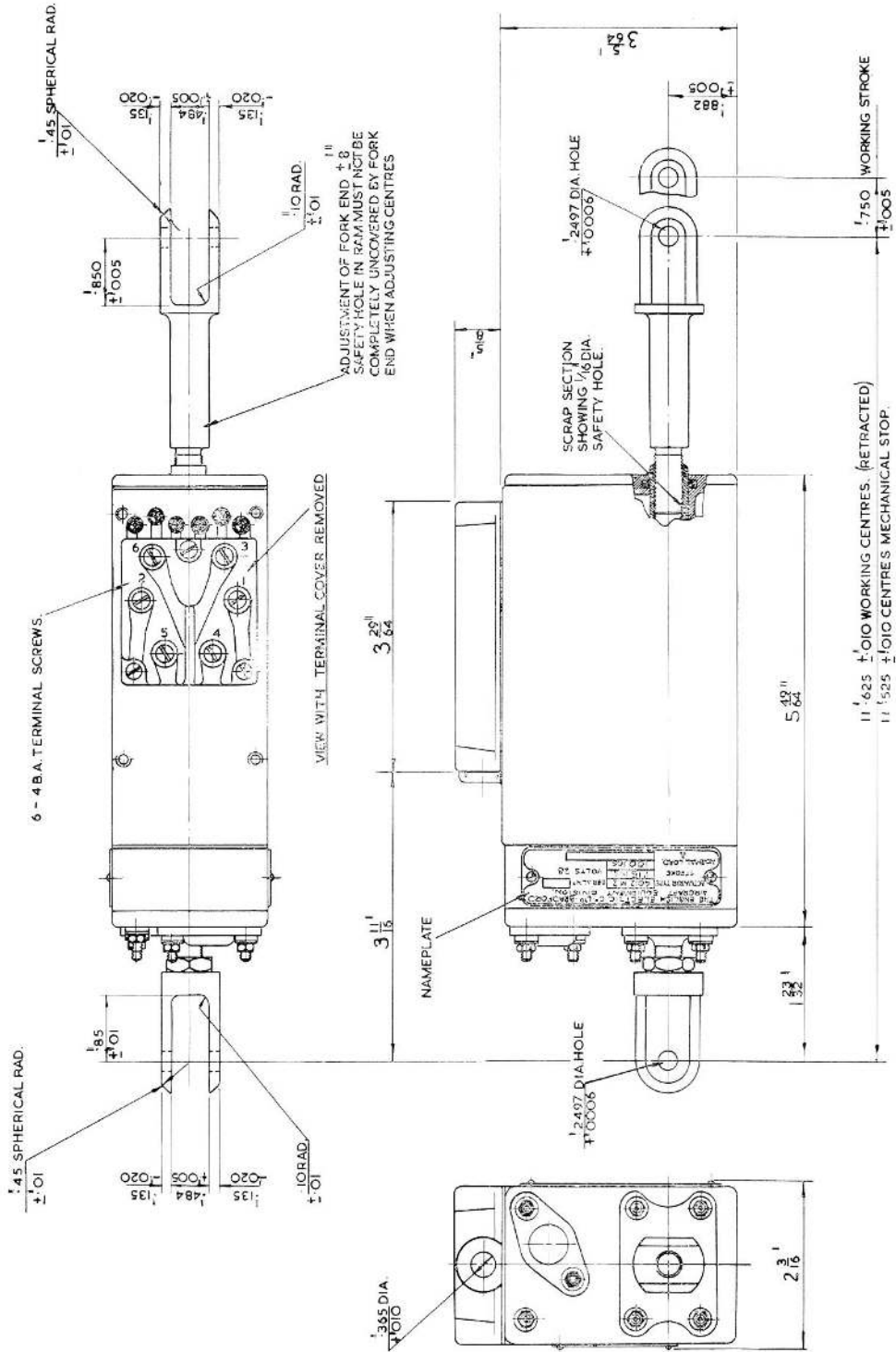

Fig. 2. Installation diagram

RESTRICTED

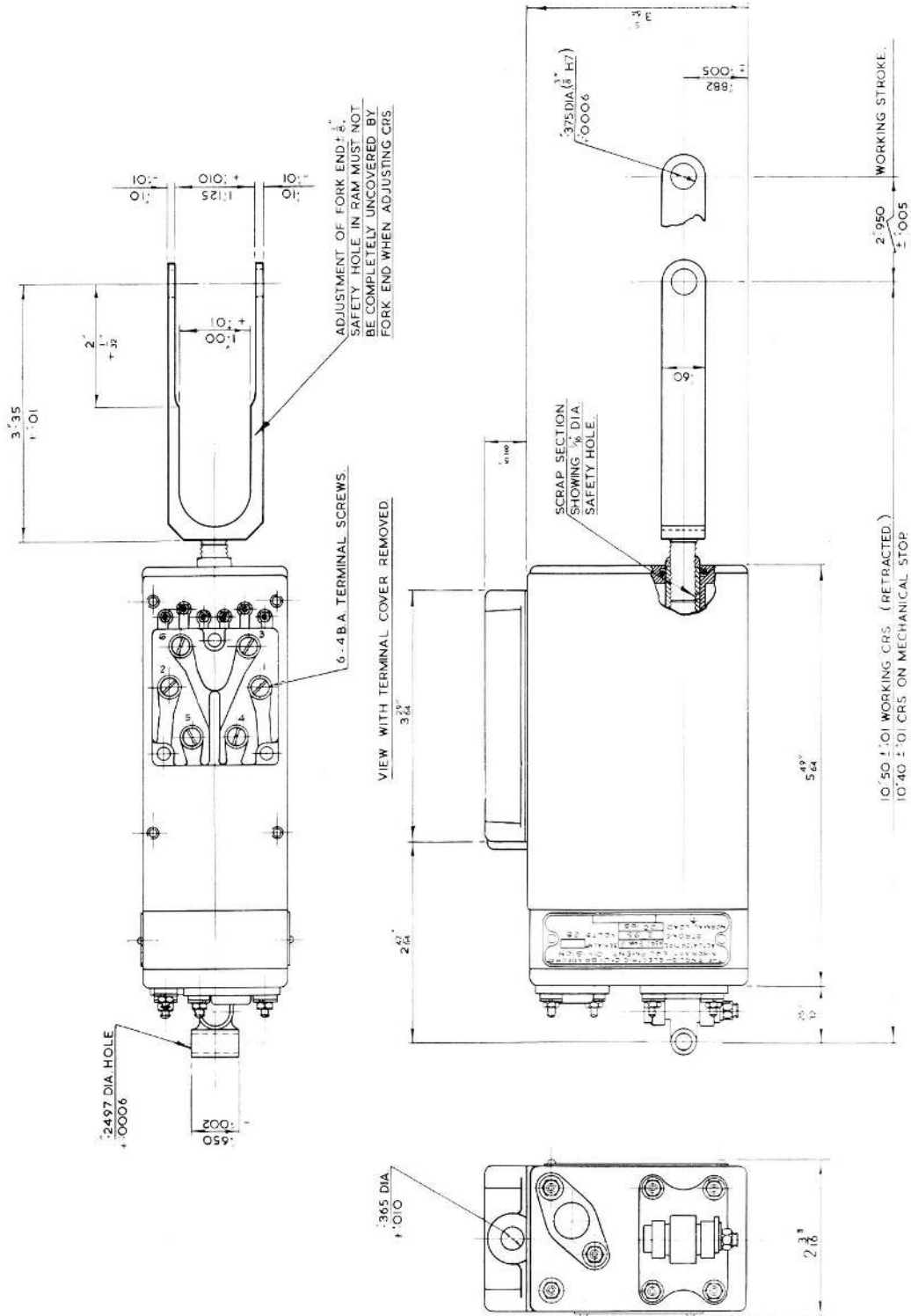

Fig. 2. Installation diagram

RESTRICTED

This file was downloaded
from the RTFM Library.

Link: www.scottbouch.com/rtfm

Please see site for usage terms,
and more aircraft documents.

